



**ATHENA**  
EUROPEAN UNIVERSITY



University of Maribor Press

**ATHENA**

Advanced Technology Higher Education Network Alliance

# **ATHENA Research Book**

**// Volume 1 / 2022**

József **GYÖRKÖS**

Ron **BLONDER**

Anne **FRIEDERIKE DELOUIS**

Jana **JAVORNIK**

Konstantinos **PETRIDIS**





**ATHENA**  
EUROPEAN UNIVERSITY



University of Maribor

# **ATHENA Research Book,**

## **Volume 1**

### **Editors**

József Györkös, Ron Blonder, Anne Friederike Delouis,  
Jana Javornik, Konstantinos Petridis

November 2022

<b>Title</b>	<b>ATHENA Research Book, Volume 1</b>
<b>Editors</b>	József Györkös (University of Maribor)
	Ron Blonder (Weizmann Institute of Science)
	Anne Friederike Delouis (University of Orléans)
	Jana Javornik (University of Leeds)
	Konstantinos Petridis (Hellenic Mediterranean University)
<b>Editorial Board</b>	Daniele Baretin, Gino Bella, Pascal Bonnet, Nuno Escudeiro, Paula Escudeiro, Anne Friederike Delouis, Janja Hojnik, Petridis Konstantinos, Kristof Van Laerhoven, Pietro Oliva, Asta Radzevičienė, Zoran Ren, Hubert Roth, Thomas Seeger, Viktorija Skvarciany, Michael Tatarakis, Dainius Udris, Dimitra Vernardou, Tatjana Welzer
<b>Reviewers</b>	Josep-Maria Arauzo-Carod, Gordon Campbell, Aleksandra Dugonik, Catherine Grillon, Helen Hughes, Jana Javornik, Maria Kafesaki, Sašo Karakatič, Aksinja Kermauner, Peter Kokol, Antonios Konstantaras, George Kritsotakis, Tina Maver, Paula Peres, Nikoloas Petrakis, Božidar Potočnik, Martin Rakuša, Shelley Rap, Dirceu Esdras Teixeira, Luísa Valente Cruz Lopes, Kathia Zaleta
<b>Technical Editing</b>	Saša Kuhar (University of Maribor)
<b>Cover design</b>	Katja Udir Mišič (University of Maribor)
<b>Published by</b>	<b>University of Maribor University Press</b> Slomškov trg 15, 2000 Maribor, Slovenija <a href="https://press.um.si">https://press.um.si</a> , <a href="mailto:zalozba@um.si">zalozba@um.si</a>
<b>Volume</b>	First
<b>Publication type</b>	E-Book
<b>Available at</b>	<a href="https://press.um.si/index.php/ump/catalog/book/735">https://press.um.si/index.php/ump/catalog/book/735</a>
<b>Published</b>	Maribor, November 2022



© University of Maribor, University Press  
/ *Univerza v Mariboru, Univerzitetna založba*

Text © authors, Györkös et al., 2022

**This work is licensed under the Creative Commons Attribution 4.0 International License.**

This license allows reusers to distribute, remix, adapt, and build upon the material in any medium or format, so long as attribution is given to the creator. The license allows for commercial use.

Any third-party material in this book is published under the book's Creative Commons licence unless indicated otherwise in the credit line to the material. If you would like to reuse any third-party material not covered by the book's Creative Commons licence, you will need to obtain permission directly from the copyright holder.

<https://creativecommons.org/licenses/by/4.0>

<b>Project Name</b>	<b>Advanced Technology Higher Education Network Alliance – ATHENA</b>
<b>Project Number</b>	101004096 ATHENA
<b>Project Date</b>	October 2020 – September 2023
<b>Project partners</b>	Hellenic Mediterranean University Niccolò Cusano University Polytechnic Institute of Porto University of Maribor University of Orléans University of Siegen Vilnius Gediminas Technical University



Co-funded by Erasmus +



#European Universities  
Building the universities  
for the future

CIP - Kataložni zapis o publikaciji  
Univerzitetna knjižnica Maribor

378 (4) (082) (0.034.2)

ATHENA Research Book [Elektronski vir]. Vol. 1 / editors József Györkös ... [et al.]. - Maribor : University of Maribor, University Press, 2022

Način dostopa (URL):

<https://press.um.si/index.php/ump/catalog/book/735>

ISBN 978-961-286-658-7

doi: 10.18690/um.3.2022

COBISS.SI-ID 130800899

**ISBN** 978-961-286-658-7 (pdf)  
978-961-286-659-4 (softback)

**DOI** <https://doi.org/10.18690/um.3.2022>

**Price** Free Copy

**For Publisher** prof. dr. Zdravko Kačič, Rector of University of Maribor

**Attribution** Györkös, J. et al. (ed.). (2022). *ATHENA Research Book, Volume 1*. University of Maribor Press. doi: 10.18690/um.3.2022

# Introduction by the Editors

The ATHENA European University is an alliance of nine Higher Education Institutions with the mission of fostering excellence in research and innovation by facilitating international cooperation. The ATHENA acronym stands for Advanced Technologies in Higher Education Alliance. The partner institutions are from France, Germany, Greece, Italy, Lithuania, Portugal, and Slovenia: the University of Orléans, the University of Siegen, the Hellenic Mediterranean University, the Niccolò Cusano University, the Vilnius Gediminas Technical University, the Polytechnic Institute of Porto, and the University of Maribor. In 2022 institutions from Poland and Spain joined the alliance: the Maria Curie-Skłodowska University and the University of Vigo.

The first volume of the ATHENA Research Book (ARB) is published as an ATHENA project deliverable within the work package on research (WP4). The planned finalisation of the project is set for September 30, 2023, resulting in the working concept of ATHENA European University. Two volumes of the ARB are planned by the end of the project. Research books are not just WP4 oriented; rather, they relate directly to the topics covered by other WPs, like education, internationalisation, and university-industry collaboration.

**The ATHENA Research Book, volume one.** The call for contributions was published in November 2021. A range of manuscripts was submitted, including review papers, original research papers, student contributions, and short reports.

*Review Papers* present and analyse previously published research activities based on relevant publications. *Original Research Papers* present scientific research achievements and research activity. The authors are primarily researchers from the ATHENA European University partner institutions, highlighting flagship research projects and the potential for future cooperation between the alliance partners. Both original and review papers are reviewed by external reviewers. The list of reviewers in alphabetic order is shown in the book. As a means of fostering open access journals, reprints of already published achievements of ATHENA partners were also encouraged in the call for contributions. *Student Contributions* are published in a separate chapter. These are either short papers from student Master or PhD theses, or short student papers on research-led or research-based teaching, whereby supervisor involvement was possible. The concept of *Short Reports*, aimed

initially to be published in the introductory section of the Research Book, was changed according to the preliminary concept of the ARB. The number, structure, and content of received short reports have not fulfilled our aim to address a wider audience by reporting on (a) research activities, (b) events, and (c) scientific book reviews. The received short reports reflect the activities of the ATHENA partners and provide valuable insight into ongoing research. Student contributions and short reports were not externally reviewed and are thus published upon the decision of the Editors.

**To the ATHENA project management by the Editors.** In the ATHENA project proposal, the annual ATHENA Research Book sought to provide a platform that promotes joint and interdisciplinary research projects by both advanced and early-career researchers in two volumes. However, during the project, the concept of the Research Book has evolved, reflecting the newly discovered opportunities and capabilities of the ATHENA partners, and challenging the initially conceived concept of the publication. Based on the experience of editing and publishing the first volume of the ARB, the Editors thus recommend to the leadership of the project a slight change of the research book concept. Lessons learned in trying to attract the authors and to manage the peer review process with external reviewers led us, the Editors, to the following conclusions: (a) the level of research production of the ATHENA partners is relatively high, and the authors are active in the international scientific community; (b) in spite of evolving open access and Leiden/DORA initiatives, the researchers remain focused on high-ranking impact journals; and (c) the non-topic orientation of the Research Book is causing concerns for the Editors about the unbalanced paper quality, missing submission of some research fields, and has proved challenging in attracting relevant and reliable reviewers. These conclusions lead us to propose changing the concept of the ATHENA Research Book so that (a) it would display the inclusive outstanding research of the partner institutions in the form of annotated bibliographies, (b) each volume should be thematically focused on a specific topic (we propose Volume Two to focus on research infrastructures), and (c) the Research Book should have a section dedicated to short contributions on the ongoing student projects at the Doctoral and post-Doctoral levels.

In conclusion, the ATHENA Research Book is an essential deliverable of the ATHENA European University project, displaying the selection of research activities of partners and communicating with potential new partners and the wider research community. This publication should be treated complementarily with the ATHENA Shared Resource Directory, an online record of research topics performed by the alliance members. With this in mind, we see both volumes of the ATHENA



Research Book, the second one to be published before the project's completion, as a pilot for final decision-making on the future concept of annual publication of ATHENA partners, displaying partners' research and innovation capabilities. The Editors of volume one propose to the project management that the following volumes of the ATHENA Research Book contain a compendium of outstanding publications in the form of annotated bibliographies and stress a specific or multidisciplinary joint research activity that reflects the profile and the performance of the ATHENA partners.

József Györkös

Rob Blonder

Anne Friederike Delouis

Jana Javornik

Konstantinos Petridis



# Table of Contents

<b>1</b>	<b>Introduction by the Editors.....</b>	<b>i</b>
<b>2</b>	<b>Original Research Papers</b>	
<b>2.1</b>	<b>Physical Sciences and Engineering .....</b>	<b>1</b>
	<b>Composer-Computer-Interpreter. A Three-way Collaborative Process to the Creation of Two New Works for Multipercussion.....</b>	<b>1</b>
	<i>Dimitrios Andrikopoulos and Nuno Aroso</i>	
	<b>Deep Neural Network as an Optimizer for FMCW THz Image Deblurring.....</b>	<b>13</b>
	<i>Tak Ming Wong, Hartmut Bauermeister, Matthias Kahl, Peter Haring Bolívar, Michael Möller and Andreas Kolb</i>	
	<b>Light-Weight Learning-Based Depth Estimation from a Single Image.....</b>	<b>23</b>
	<i>Zekarias Negese, Hartmut Bauermeister, Michael Moeller, Emanuele Rodolà and Zorah Lähner</i>	
	<b>Modelling and Characterisation of Metamaterials with Primitive and Advanced Cellular Structures .....</b>	<b>41</b>
	<i>Nejc Novak, Matej Vesenjak and Zoran Ren</i>	
	<b>Supercritical Fluids for the Treatment of Bioactive Components.....</b>	<b>59</b>
	<i>Milica Pantić, Darija Čör Andrejč, Maša Knez Marevci, Zoran Novak and Željko Knez</i>	
	<b>Applying SCRUM in a Physics II Undergraduate Course: Effect on Student Progression and Soft Skills Development .....</b>	<b>89</b>
	<i>Manolis Lourakis and Konstantinos Petridis</i>	
<b>2.2</b>	<b>Social Sciences and Humanities .....</b>	<b>105</b>
	<b>Development of an Inclusive Multiplayer Serious Game for Deaf and Blind .....</b>	<b>105</b>
	<i>Nuno Neto, Bruno Galasso, Dirceu Esdras and Paula Escudeiro</i>	
	<b>Inclusive Digital Learning through Serious Games: a Clipping for Inclusion .....</b>	<b>125</b>
	<i>Paula Escudeiro, Dirceu Esdras, Bruno Galasso, Nuno Neto and Flávio Costa</i>	
	<b>Students' Perception of Self-efficacy and Academic Engagement in School of Health of the Polytechnic Institute of Porto: an Observational Study .....</b>	<b>137</b>
	<i>Manuela Amorim, Diana Tavares, Maria Céu Lamas, Sandra Mota and Ana Salgado</i>	

---

## 2.3 Life Sciences .....159

**Health Promotion Conceptual Evolution and Program Development: a Literature Review** ..... 159

*José Félix, Paula Clara Santos and Pilar Baylina*

**Ketamine Antidepressant Properties: a Systematic Review of Clinical Trials** ..... 175

*Diogo Ferreira, Agostinho Cruz and Marlene Santos*

**Potential Drug Interactions between Oral Antineoplastic Agents and Opioid Analgesics** ..... 199

*Cláudia Antunes, Daniel Carvalho and Ângelo Jesus*

**Potentially Irritant Preservatives in Newborn Baby Cosmetics – Analysis of Labels of Products Sold in Portugal**..... 215

*Diana Pinto, Mariana Coelho, Marisa Machado, Agostinho Cruz and Fernando Moreira*

## 3 Student Contributions

### 3.1 Physical Sciences and Engineering .....231

**Bringing VLC into ToF Imaging: Pseudo-Passive Indoor ToF Imaging** ..... 231

*Faisal Ahmed, Miguel Heredia Conde and Otmar Loffeld*

**CS-based ToF Imaging**..... 237

*Alvaro Lopez Paredes, Miguel Heredia Conde and Otmar Loffeld*

**Dose per Pulse Monitoring of MeV Photon Beams**..... 243

*Sara Pettinato and Stefano Salvatori*

**Heat Capacity and Internal Thermal Resistance Measurements in Lithium-ion Cells** ..... 249

*Paola Serao and Gino Bella*

**Multi-sensor Characteristics and Application-based Processing** ..... 255

*Zhouyan Qiu, Pedro Arias- Sánchez, Joaquín Martínez-Sánchez*

**Semantic Information Discovery and Complex-Valued Deep Architectures for SAR Data Processing** ..... 261

*Reza Mohammadi Asiyabi, Mihai Datcu, Andrei Anghel and Holger Nies*

**Single-measurement Determination of Molar Fraction and Temperature of Binary Gas Mixtures from Combined Laser Induced Grating and Four-wave Mixing Signals** ..... 265

*Jonas I. Hölzer, Dimitrii N. Kozlov and Thomas Seeger*

---

<b>3.2 Social Sciences and Humanities .....</b>	<b>271</b>
<b>Instagram for Information and Publicity Purposes During the Covid-19 Pandemic .....</b>	<b>271</b>
<i>Andi Poplas, Nina Planinšek, Miha Rušnik, Rok Nabergoj, Vili Podgorelec and Ines Kožuh</i>	
<b>Living the Culture through the <i>Commoning</i> .....</b>	<b>281</b>
<i>Daniele Paragano and Giada Semeraro</i>	
<b>Social Media as a Channel for Cooperation, Co-creation and Communication between Companies .....</b>	<b>287</b>
<i>Daša Kompan, Kim Obaha, Nina Pahič, Sabina Trop, Vili Podgorelec and Ines Kožuh</i>	
<b>3.3 Life Sciences .....</b>	<b>295</b>
<b>Pain Overview: Classification, Conceptual Framework, and Assessment .....</b>	<b>295</b>
<i>Nuno M Duarte, José A Garcia-Pedraza and Marlene E Santos</i>	
<b>Tablet Splitting: Influence of Technique and Tablet Format .....</b>	<b>303</b>
<i>Ana Alexandre, Sónia Ferreira and Ângelo Jesus</i>	
<b>Use of the Smartphone Camera to Monitor Adherence to Inhaled Therapy .....</b>	<b>313</b>
<i>Sofia Ferraz, Rute Almeida, Pedro Vieira-Marques and Nuno Escudeiro</i>	
<b>4 Short Reports</b>	
<b>4.1 Physical Sciences and Engineering .....</b>	<b>321</b>
<b>A 2-Tap Indirect ToF CMOS Image Sensor for Multi-Frequency Demodulation .....</b>	<b>321</b>
<i>Peyman F. Shahandashti, P. López, V.M. Brea, D. García-Lesta and Miguel Heredia-Conde</i>	
<b>Adaptive Model Predictive Control with Regularized Finite Impulse Response Models .....</b>	<b>327</b>
<i>Christopher Illg and Oliver Nelles</i>	
<b>Introducing A Microservice-Based Mobile Software Product Line – a Technical Debt Perspective .....</b>	<b>333</b>
<i>Luka Pavlič, Tilen Hliš, Marjan Heričko and Tina Beranič</i>	
<b>The Impact of Using Serious Games as a Learning Tool in Higher Education .....</b>	<b>339</b>
<i>Tina Beranič and Marjan Heričko</i>	

## 5 Reprints

### 5.1 Physical Sciences and Engineering .....347

**An Overview of Methods for Generating, Augmenting and Evaluating Room  
Impulse Response Using Artificial Neural Networks..... 347**

*Mantas Tamulionis*

**Analysis of Linux OS Security Tools for Packet Filtering and Processing ..... 357**

*Dmitrij Melkov, Šarūnas Paulikas*

# Original Research Papers





# Composer-Computer-Interpreter. A Three-way Collaborative Process to the Creation of Two New Works for Multipercussion

Dimitris Andrikopoulos<sup>1</sup>, Nuno Aroso<sup>2</sup>

<sup>1</sup> ESMAE/IPP-CESEM, Rua da Alegria 503, 4000-045, Porto, Portugal,  
dimitrisandrikopoulos@esmae.ipp.pt,

<sup>2</sup> INET, Campus Universitário de Santiago, Universidade de Aveiro,  
3810-193 Aveiro, Portugal, aroso@ua.pt

**Abstract.** *Last decades we see a redefinition in the way of interaction between the performer and the composer, an interaction that led to the discovery of new paths of creative collaboration between parts. This article is a study of this relationship as presented in the works “Solo I” for multipercussion and “Solo for Two”, a duo for two multipercussion sets by Dimitris Andrikopoulos. We address, firstly, the collaborative process between the composer and the interpreters from the early stages of the creation of the works up to the moment of performance and recording of the pieces and how this process and collaborative attitude influenced basic parameters of the composition. Further, we address issues related to the generation of compositional material through algorithmic processes, material that was used in the creation of the pieces, itself a type of collaboration between the composer and the computer inside a Computer Assisted Composition environment.*

**Keywords.** Collaborative musical activities, multipercussion, CAC, unconventional setups, contemporary music

## 1 Composer versus Interpreter. A case of chickens and eggs.

The word symbiosis is the best word to describe the relationship between composers and interpreters throughout the history of western music. Even if this is a clear fact, this relationship took different forms in the course of time. In the early renaissance period, performers were expected to complete the scores of the composers by even “*adding accidentals and place the words under the notes in vocal music*” demonstrating the highly collaborative symbiotic system in order to have the works performed.

Slowly, with the development of a more adequate system of notation and the necessity of the composers to indicate more clearly their musical thought, we have a decrease in this highly collaborative relationship, even if much of the baroque period music still includes a high level of improvisation inside the basic skeleton of the notated musical text, arriving finally to the 19th century when we have a drastic change of the paradigm. Going into the nineteenth century, the new public attributes to the composer/performer figure almost supernatural abilities, Paganini and Liszt are great examples of this. Coming out of many centuries of tradition where the composer has always been deeply involved in the performance of his works even as a player, we are moving to a new era, where this image slowly fades away. A new distinctive role between performer and interpreter is formed, resulting in the participative role of the composer to the final performance to be given up. Adding to that, the individualistic new approach to musical creation by the composers at the time, led to a situation where the composer is considered a unique artist-creator, a “hero” to be venerated by the society, an artist which his works are slowly being personified, and in the same way as the composer himself, are iconoclastically worshiped by the audiences and have to be performed “as written in the score”.

With the more frequent performance of dead composers in the late nineteenth and early twentieth century, the gap of the historically close collaboration between composer and interpreter has only been amplified. Inside this schism, and at the same time as result of this situation, one thing became clearer; the necessity of composers to have a bigger control on the interpretation and performance of their music. This thing became possible through the only tool that a composer possesses: a more detailed and precise notation of the musical text. From the Doric style scores of the baroque era we are now in the time when a score through the detailed notation of dynamics, articulation, tempo variation, performance indications and even the suggestions over the emotional impact that music had to achieve in a given point, diminish even more the collaborative relationship between interpreter and composer and reduce the interpreter into a mere reproductive medium of the composers ideal interpretation of his text. A characteristic example of this attitude, we can note on a response by Gustav Leonhardt in an interview. Leonhardt responded: “*No, I have nothing to say, I am only a player.*” “*As opposed to?*” asked the interviewer, “*to a real musician, which is a composer*” the final answer (Sherman, 1997).

---

Nevertheless, taken all this mythology apart, interpreters frequently throughout the history of western music rearranged the written scores. Even today we see, especially in vocal and operatic repertoire, a big amount of improvisation by the performers and many times even a “drastic” reinterpretation of the score, all excusable under a mighty word presented: “*Tradition!*”. Anyone who played in an orchestra has experienced the sometimes almost barbaric intervention of conductors, by introducing cuts and changing the duration of movements in order to please their concert duration necessities, or other times, by “improving” the orchestration of the score, or even changing the musical text itself. As we move further into the twenty-first century, happily, these attitudes become more and more stories from the past.

The next step in this relationship we can trace after the second world war. The power behind the radical change taking place after the war was the necessity of the composers to cut the relationship between the new music and the music of the past. It was a time for a music that aimed to express a new society with new ideals and being free of the social and artistic decadence, in their view, of the pre-war society. Taking in account as well the fast development and influence of electronic music and the new aesthetics introduced by the new studios that were appearing all over Europe and America at the time, we have a profound reevaluation of what musical sound is. All this influence, combined with the inquisitive minds of young composers, gave a start to an intensive research that led to a reevaluation of what instrumental technique is, how sound is produced by the instruments, the extension of sound resources beyond the spectrum of the until then accepted “*musical*” sound and the inclusion of noise into the possible sound resources used by the composers. Inevitably, all the above led to the change of paradigm of interpretation and performance itself (if Futurist composers were still alive, they would have been sitting in a corner laughing).

In this new environment, interpreters take a new role into the creative process. From faithful re-creators of the original idea, they become important elements in helping the composer to understand the new sound possibilities, to understand the new mechanics on how all these new sound palettes can be produced effectively, and actively contribute to the extension of the technical resources presented to the composer.

To this development, there is no better example than the research and collaboration between performers and composers when making music for percussion instruments. It is very often said that the 20th century has been the century of percussion development. Composers took advantage, as well as, an active role in this. From an emphatic role in the orchestra scores of the nineteenth century, the percussion family emancipated to an individual - always in development group - that gave an immense space to composers in order to challenge their limits of imagination and their creativity.

## 2 The big extension of the research on sound resources in percussion. A never-ending story.

Percussion has been part of human expression and communication since the beginning of time. Alongside with the voice, percussion is one of the first forms of musical enunciation and still is today a fundamental part of the popular musical manifestations from Africa to Asia, from the Americas to Europe. Despite the percussion omnipresence in the globe, in its many forms and cultural insertions, inside the scope of classical music percussion was relegated to a secondary plan.

The pioneering, and from several points of view, revolutionary role of percussion family in the development of Western music took place in the XX century starting in the decade of the 30s with the presentation of *Ionisation* by Edgar Varèse. *Ionisation* was the first work written for percussion ensemble. Composers like John Cage, Edgar Varèse, Henry Cowell following the visionary example of the futuristic movement altered the role of this instrumental family, from its traditional function inside the orchestra to a new and revolutionary character, as a sound extender, capable of accompanying the ever-growing needs of composers' imagination and virtuosity.

A varied range of traditional non-western instruments appears in the percussion section which, if on the one hand, respond to the ethnic-instrumental exoticism that composers of the time sought, on the other, compel percussion players to a mastery of wide performance techniques. The percussionist of the second half of the 20th century became a versatile musician. Composers delegate to the interpreter extended and increasingly complex functions that include, additionally to the mastery of the multiple instruments of the percussion family - skins, keyboards - the mastery over other unconventional sound sources. The development of percussion was effulgent in subsequent musical "revolutions" up to the present day. Music for percussion has become a flag of musical innovation.

The most notable characteristic of contemporary percussion is the infinity of its resources that allows both composers and interpreters to build their own musical entities. This vast amount of new resources and techniques create even more the necessity of a bigger interaction and collaboration between the composer and the interpreter from the early stages of musical creation. When writing for new instruments or instruments that are out of the sphere of the "conventional resources", new challenges arise to both composers and interpreters.

Except from the conventional instrumentarium, there is significant research on home-made, junkyard, unconventional instruments that require even more a completely different approach both on composition and interpretation as well as on issues of notation, intensifying even more the necessity for a closer collaboration between the composer and the interpreter.

The works by Dimitris Andrikopoulos "*Solo I*" and "*Solo for Two*" are two examples in this line, mainly in the research and the extension of new timbre resources. In both works, the sound sources/instruments have to be chosen by the interpreter according to some general instructions by the composer.

### 3 “Solo I” and “Solo for Two”. A search for new sound resources.

“Solo I” and “Solo for Two” are the first two works written for percussion by the composer, Dimitris Andrikopoulos. Both pieces are based on the idea of human language and speech. They express a research on the almost chaotic patterns created by a multitude of people talking at the same time, where the various rhythmic lines (in the instrumental musical discourse) coexist and interact.

Nuno Aroso’s work as an interpreter is mainly focused on an extended research to non-regular instrumental settings, settings that go out of the “canon” of traditional percussion, as for example home-made instruments.

Both pieces carry this influence. From the early stages of the composition process, before even start dealing with the musical text itself, there has been a series of conversations between composer and interpreter over the sonic character of the works and the interest of both into exploring alternative instruments and timbres that, in the first place, could create an individual sonic signature in every piece and, secondly as a result of the first, create challenges to the composition process as well as to the final interpretation of the pieces. It is important here to say that both works are part of a major set of works for percussion, in progress, that looks into the above problematic.

In this sense, “Solo for Two” is more adventurous than “Solo I”. “Solo I”, being the first percussion work written by the composer, follows a more conservative approach to both questions. The compositional challenges are more present on how the compositional resources used in the piece are combined through the use of the different construction materials of the instruments (wood, skin, metal); in a way, a more “*contrapuntal*” approach between timbres.

For the creation of the rhythmic material used in the creative process of Solo I and Solo for Two, the Patchwork Graphic Language (PWGL) application was used. PWGL is a Common Lisp application and was developed in 2002 in the Sibelius Academy in Helsinki by a research team consisting of Mikael Laurson, Mika Kuuskankare, Vesa Norilo and Kilian Spote. It is a visual language combining the strong points of its predecessor Patchwork, developed in IRCAM in the decade of 1980, but with a modern, easier, more flexible and stronger user's interface. For the case of Solo I and Solo for Two, the Gestural Rhythms (GRhythms) library, created by Magnus Lindberg, was used as a central tool for the manipulation of the basic rhythmic material.

A 13-note series, used as a basic material for more works in the last years by the composer, serves as the starting point for the creation of the rhythmic material used in both pieces. The interval distances between the notes in the series (half-tone equals 1, whole-tone equals 2, minor third equals 3 etc.) become the basic numeric source used for the construction of the pieces. Both pieces use the numbers extracted from the fourth variation of the original series: (1 2 3 7 8 2 2 9 5 4 9 4 9). Through a series of diverse manipulations such as, insertions of constant values in different areas of the series, creation of new series out of the common attack points between two series resulting out of the previous processes, increasing the contrast of the values in a series by elevating them by an exponent and the readjusting the results into the previous

total length of the series, percentage manipulations of the original lengths or inserting different rhythmic structures inside other rhythmic structures, some of the many manipulations that the original material went through, created a considerable amount of rhythmic tables that provided a large spectrum of possibilities to be used in the different parts of the works. The final choice of the material used for the realization of the pieces was not subjected to any kind of formalization but was freely chosen during the composition process.

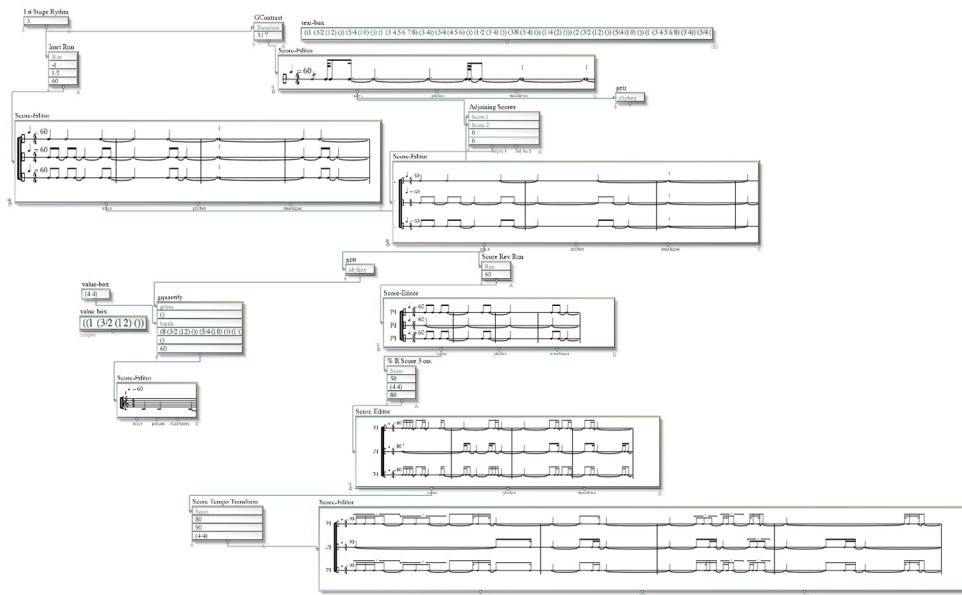

**Figure 1.** Example of the use of PWGL

On the instrumentation level, as mentioned earlier, there has been from the early stages of the creation of the pieces a close and collaborative relationship between the composer and the interpreter through various conversations on the sonic character of both pieces and subsequently, on the choice of the instruments used.

Related to the timbre character of “Solo I”, a more “naturalistic” approach was followed for the choice of the instruments used. The three major material families (skin, wood, metal) of percussion instruments were used. As a first try, the first instrumentation of the piece was including: Marimba (the lower first octave of the instrument), 2 Bongos, 2 Congas and a large orchestral Bass Drum, creating a 5 set of natural skin membrane instruments, 5 woodblocks and 5 cymbals where the lower 3 are sustained cymbals (low-middle and high) and the high 2 must be Chinese cymbals. The more interesting part of this instrumentation was that the large Bass Drum has to be taken out of its support mechanism, be placed on the floor and always to be played by the use of a foot pedal.

After the first performance of the work it was clear that the marimba was sounding as a foreign object to the sonic image of the piece, mainly due to the reason marimba being the only pitched instrument of the set in combination with the limited pitches used (only the first, lowest octave of the instrument). It was clear that a different approach had to be

followed. The nature of the marimba itself, a set of wooden plates of different sizes, gave the solution to this problem.

As so, 5 pine wood plates of different lengths were created, resulting in 5 different non-pitched sounds. The sound of the instruments has a distant resemblance to the traditional wooden Greek instrument, “Simantron”, an approximately 3 meters long wooden plate and its smaller variations, used in many Orthodox Greek Monasteries to announce the important parts of the day.

The marimba part was rewritten in order to use these newly created homemade instruments. Again, in this part, the collaboration between composer and interpreter was an essential factor for the solution of this challenge, mainly for the choice of the material and the size of the wooden plates used in the piece. The introduction of this new element intensified as well the sonic idiosyncrasy of “Solo I” and finally, in a practical sense, the absence of a marimba added to the flexibility and mobility, for future performances, of the work.

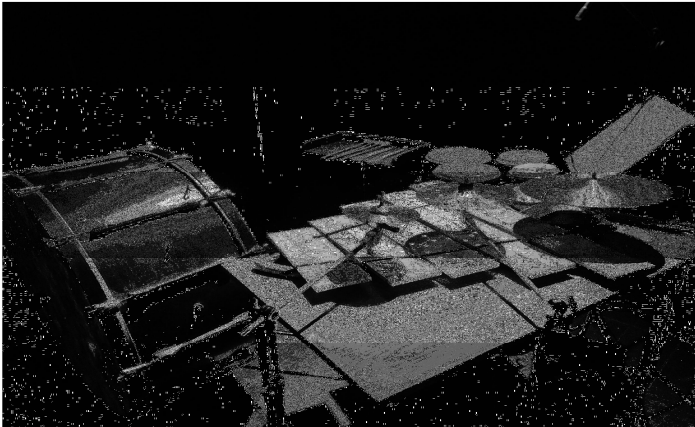

**Figure 2.** “Solo I” set up

Another important factor in this collaborative process has been the input of the performer to the creation of the final score of the work. Many times, the compositionally correct choices for the notation of a work made by the composer are not the most efficient neither the most intelligible ones for the practical realization of the piece by the interpreter.

In the case of ‘Solo I’, being constructed out of different layers of algorithmically generated material, the first choice was to create a score that could clearly demonstrate this process. This resulted in a 4-staff score demonstrating clearly its multi-layered compositional structure, but at the same time, the final result was moving away from the commonly used notation for a multi-percussion setup. Apart from the high level of difficulty of the piece, this type of notation created extra challenges to the interpreter. After a lot of conversation between the composer and the interpreter a new score was created, adapting a different approach to the notation of the work and coming much closer to the visual expectations of the performer than the, theoretically more correct, composers’ score.

**Figure 3.** First page of “Solo I”. First and second version.

“Solo for Two”, the second work in this series, has been a more adventurous work in terms of sonic research and the use of non-standard percussion instruments. From the early stages of the creation of the work there has been a close conversation between the composer and the Magnet Duo - Nuno Aroso and Mario Teixeira. The challenge in this case was to create a piece that had to go out of the standard instrumentarium of percussion instruments, through the use of different kinds of homemade instruments in order to create an even more individual sonic character.

For “Solo for Two” only metal instruments can be used. Even if there is in the scores a suggested instrumentation for the piece, the interpreters are free to choose a completely different setup with only two constraints applied. Firstly, they must combine for every layer metal instruments with a different sonic character, instruments with shorter and longer decay and a broad dynamic spectrum (ppp to fff). Secondly, the lowest line of the second percussionist, a larger, longer decay instrument has to be used and to be controlled by a foot pedal, similarly to the case of “Solo I”.



**Figure 4.** Different setup examples for “Solo for Two”

Up to the day, 3 different groups have performed “Solo for Two” and 3 completely different setups have been used by the performers. Metal pipes, kitchen pans, aluminum bars, hoes, anvils, different shapes and sizes of metal pieces in combination with different sizes of petrol barrels played with a foot pedal, have been some of the instruments used. Even if the



---

rhythmic structure of the piece always remains the same, every performance of the work opened a completely different path to new sound worlds.

It is a fact that in both above cases, *“Solo I”* and *“Solo for Two”*, the research interests of the interpreters have been a crucial and influential factor to the work of the composer. It is extremely important to say that the creative space created by the performers, this opening they presented into new sound colors and their will for experimentation with different materials and homemade instruments provided a great opportunity for the composer to follow ways that went away from the traditional writing for percussion, as well as to extend in some cases the technical possibilities of the instruments used.

In order to compensate for some practical problems presented during the rehearsal period, problems resulting out of the sonic constraints of the homemade instruments, solutions had to be devised. A simple example is the foot pedal used in *“Solo for Two”*. In the case of the use of a large petrol barrel, a normal pedal beater because it comes closer to a hard head beater, produced much more high frequencies, erasing the lower and more resonant sound of the petrol barrel. In this case different solutions like adding a felt cloth cover to the pedal or in the latest presentation of the piece, “dressing” the pedal with a wool thread and changing its character from a hard to a soft beater was used in order to succeed the timbre that the composer asked for this part.

## 4 The Third Person: The Composer-Computer collaboration.

For the creation of *“Solo I”* and *“Solo for Two”*, as mentioned before, the PWGL application has been used.

From early in the decade of the 1950’s composers used computers as part of the creation process in order to solve compositional problems and make complex calculations, giving birth to what is known later as Computer Assisted Composition (CAC). An area of CAC that gained a predominant space into composition practice is algorithmic composition. According to Karlheinz Essl, an Austrian composer that dedicated much of his work to algorithmic composition, an algorithm is a “a predetermined set of instructions for solving a specific problem in a limited number of steps.” (Essl, 2007).

Even if the term algorithmic composition implies a use of computers, the idea of solving a specific, musical in our case, problem is much older than the discovery and the use of computers. Any simple set of rules, “constraints” in a more “binary” language, such as medieval counterpoint, Bach’s instructions in his Musical Offer or in his Goldberg Canons, the musical dice game of Mozart, or the use of the Golden Rule as the constant for formal segmentation in works by Debussy or Bartok, few of the many examples existing, are nothing more than individual algorithms that when put together produce the solutions to the musical questions asked by the composers. Even our simple understanding of the music of a period, what we call musical style, is a result of the rules that govern this particular style.

The big question in the case of the two percussion works is if and how we can consider the computer as a collaborator, a third party element in the realization of the composition process. If the answer is yes, until what point does this collaboration influence the creative process? In order to respond to this question it is necessary to mention the way that the computer interfered in the creative process.

The use of a CAC permits the creation of a massive number of solution variants on a previously formulated musical problem. By changing and experimenting different parameters in the different formalized elements of a piece, in the case of “Solo I” for example, the exponent values which the rhythmic cells have to be elevated in the rhythm-contrast process, different solutions have been presented. As a result, this firstly influenced the decision-making process of the composer. This real time multiple-solution process provides a variety of solutions that allow, metaphorically, to “tune” a musical idea, a musical concept. At the same time, if the results of the processes are not being up to the expectations, this demonstrates that there are flaws in the original concept. The system’s results are always dependable on the questions posed and the variation of the parameters given for the calculations. The computer’s “mind”, in a way functions as a mirror of our thought, an image that many times when composers are busy with the technical parts of the creative process, tend to forget. This demonstration of the flaws permits a fast reevaluation of the original concept in order to bring it up to the level that it can produce the expected results, a process much similar to the way that scientific research works.

Another important contribution is that the results produced out of these processes permit what is generally called a Class Composition. The production of a bigger amount of acceptable results permits a larger amount of variations of the particular piece. In this sense there is not only one way that can be followed for the realization of the work but many, there is not only one work but many variations of a work, variations that can provide different narratives and dramaturgical ways to be followed. As in many cases the focus for a contemporary composer moves away from the “how” to the “what”, to the adequate filtering of the results presented. And this is not something new.

Frank Dietrich mentions that the computer enhances the artist’s ability to set up “thought experiments” (Dietrich, 1987). In opposition to some traditional idea that somehow the use of CAC substitutes the composer’s ability to imagine, think or choose, CAC functions as an enhancement of the composers’ creative mind. It enriches the creative processes by creating the space for a deeper insight, a deeper understanding of the processes used during the composition of a work and on how these processes function practically. Many times, are assigned to the computer tasks that could consume a significant time for a human to realize, permitting in this way the composer to focus into more important issues as the narrative and the dramaturgy of a work. Is this a collaborative process? As in the case with the collaboration with the interpreter, yes it is, to the level that the composer permits these external parameters to influence and constrain his creative work.

---

## 5 Conclusions

This study tried to present the different processes and ways of collaboration used during the creation of two works for percussion by Dimitris Andrikopoulos, ‘Solo I’ and ‘Solo for Two’.

All the processes presented arouse various questions related to the constantly changing relationship between composer and performer as well as the new founded relationship between the composer and his recently hired assistant, the computer.

It is more than normal to ask, are we in front of a new reality for composers? Are we in the early phases of a new relation between composers and interpreters? In order to respond this we have to ask ourselves, what is the difference to the past? And when we speak about the past, in this case we speak about the post nineteenth century solitary-genius tradition of western music that has been the predominant one up to our days.

One direct answer comes out of the percussion paradigm and the research on new timbre recourses that has been the focus of this study. The more intense this research becomes, the further from the historically established practices of interpretation we move, the more we look on the extension of the technical and interpretative recourses and the greater the level of specification on the way how the different sound elements of a work can be produced, the more active will be the participation of the interpreter in order to translate effectively and clearly to the score all this new information. The interpreter indirectly becomes as well one of the basic resources for the realization of a piece.

From the part of the interpreter, the more he influences the compositional practice the more we can speak for an individualization of the work created. Many times, this is part of the work itself. In the case of ‘Solo for Two’ the collaboration of the interpreters to the final realization of the work is indispensable. Due to the partially indeterministic character of the orchestration of the piece, it is up to the interpreters to give the final steps to the realization of the work. In a sense, the score is not finished when it is delivered to the players. There is a continuous development of the work when it is related to other interpreters. An ‘open-closed’ work. Metaphorically an asynchronous continuous collaboration between the composer, the work and its future performers.

Another interesting outcome from the collaboration of interpreter/composer, from the interpreter’s point of view, is that he conquers an ‘ownership’ of the artistic material as never before done in other creative processes guided by less shared principles. As he is part of the creation, by making decisions like the ones regarding instrumentation, for example, an idiosyncratic version of the work will be presented every time a new musician plays.

Michael Schrage in his 1990 book ‘The New Technologies of Collaboration’ defines collaboration as *“a process of shared creation, in which two or more individuals with complementary skills interact to create a shared understanding that neither had previously possessed or could have come to on their own”*. In many ways, the collaborative process between Composer-Computer-Interpreter falls inside this broad definition. A relationship that, probably, with the rapid development of technology and the creation and research of new musical resources is only going to be intensified.

## References

- [1] F. Dietrich, “The Computer: A Tool for Thought-Experiments”. *Leonardo*, 20th Anniversary Special Issue: Art of the Future: The Future of Art, 20(4), 315–325, 1987.
- [2] K. Essl, “Algorithmic composition,”. *The Cambridge Companion to Electronic Music*, ed. by Nick Collins and Julio d’Escriván Cambridge University Press, 2007, 1,07,2007.
- [3] M. Schrage, “Shared Minds: The New Technologies of Collaboration”. New York: Random House, 1990.
- [4] B. D. Sherman, “Inside Early Music”, Oxford University Press, 1997, pp. 203–4, 1997.

# Deep Neural Network as an Optimizer for FMCW THz Image Deblurring

Tak Ming Wong<sup>1,2</sup>, Hartmut Bauermeister<sup>1,3</sup>, Matthias Kahl<sup>1,4</sup>,  
Peter Haring Bolívar<sup>1,4</sup>, Michael Möller<sup>1,3</sup>, Andreas Kolb<sup>1,2</sup>

<sup>1</sup> Center for Sensor Systems (*ZESS*), University of Siegen, Germany

<sup>2</sup> Computer Graphics and Multimedia Systems Group, University of Siegen  
{tak.wong, andreas.kolb}@uni-siegen.de

<sup>3</sup> Computer Vision Group, University of Siegen  
{hartmut.bauermeister, michael.moeller}@uni-siegen.de

<sup>4</sup> Institute for High Frequency and Quantum Electronics (*HQE*), University of Siegen  
{matthias.kahl, peter.haring}@uni-siegen.de

**Abstract.** *A stable estimation of the THz model parameters for low SNR configurations is essential to achieve acquisition times required for applications in, e.g., quality control. The deep optimization prior approach was introduced with application to the estimation of material-related model parameters from THz data, which is acquired by a FMCW THz scanning system. Conceptually, this approach estimates the desired THz model parameters by optimizing for the weights of a 3D spatially coupled deep neural network. This approach was verified numerically on various THz parameter estimation problems for synthetic and real data. In this paper, we propose to combine the deep optimization prior approach to the modern 2D blind deblurring method for the FMCW THz image resolution enhancement. The experimental results show that this approach improves the lateral resolution enhancement robustly under low SNR noise condition in comparison to the per-pixel curve fitting method.*

**Keywords.** Terahertz (THz), Frequency Modulated Continuous Wave (FMCW), parameter estimation, deep learning, non-convex optimization, 3D model based autoencoder, deep optimization prior, deblurring, deconvolution

## 1 Motivation

In Frequency Modulated Continuous Wave (FMCW) THz imaging, the THz 3D image can be modelled as a formation model  $A$  in depth direction  $z$ , by repeating this process for each position (per-pixel) in lateral  $xy$  domain [1].

$$A(u; z) = \hat{e} \operatorname{sinc}(\sigma(z - \mu)) \exp(-i(\omega z - \phi)) \quad (1)$$

where the THz model parameters  $u = (\hat{e}, \mu, \sigma, \phi)$  relate to the electric field amplitude, the  $z$ -position of the surface, the width of the reflected pulse, and the phase of the spatial signal  $g(x, y, z)$ , respectively. The resulting complex valued spatial 3D THz signal  $g(x, y, z) \in \mathbb{C}^{n_x \times n_y \times n_z}$ , where  $n_x, n_y, n_z$  is the number of vertical, horizontal and depth samples.

Hence, the objective of THz model parameter estimation is to extract the parameters  $u \in \mathbb{R}^4$  of the THz model (1) at each pixel location  $(x, y)$  such that it corresponds to the given FMCW THz measurements  $G(x, y) \in \mathbb{R}^{n_z \times 2}$  by solving this non-convex optimization problem:

$$\min_u \sum_{x,y} \|A(u_{x,y}) - G_{x,y}\|_2^2, \quad (2)$$

As  $A$  is nonlinear and this problem is highly non-convex, (2) is often solved locally with classical first-order gradient descent methods.

Due to the low signal strength of the widely used THz sources, it takes up to hours to acquire high Signal-to-Noise Ratio (SNR) THz image data for robust parameter estimations, and the parameter estimation for high SNR data already requires significant optimization efforts and fine tuned parameter initialization.

Therefore, to improve the robustness of the parameter estimation process for lower SNR THz data, *deep optimization priors* [2] was proposed as a novel unsupervised deep learning approach to solve highly non-linear optimization problems. This approach extended deep image prior [3] to *non-convex* optimization problems and shows that not only the quality of the solution increases, but also the ability to find *lower energy minima*: By reparameterizing the originally *spatially uncoupled* variables  $u$  as the output of a U-net [4] acting on the data, a gradient descent algorithm is able to avoid undesirable local minima when the same algorithm on the original variables gets stuck in. Most strikingly, the quality of a classical approach (2) has a severe dependency on a good initialization with physical knowledge, while the common *random initialization* of network weights seems to be sufficient for consistently finding good local minima.

In this paper, we propose the combination of the deep optimization prior approach [2] and the THz image deblurring et al. [1] and investigate the impact of combining both methods to the resolution improvement for FMCW THz imaging. More precisely, we apply modern blind deconvolution method, such as Xu et al. [5], [6] to the result of the THz parameter estimation achieved by the 3D deep optimization prior technique [2].

Section 2 gives a brief overview of the deep optimization prior approach. The details of the deblurring and experimental result are described in Section 3.

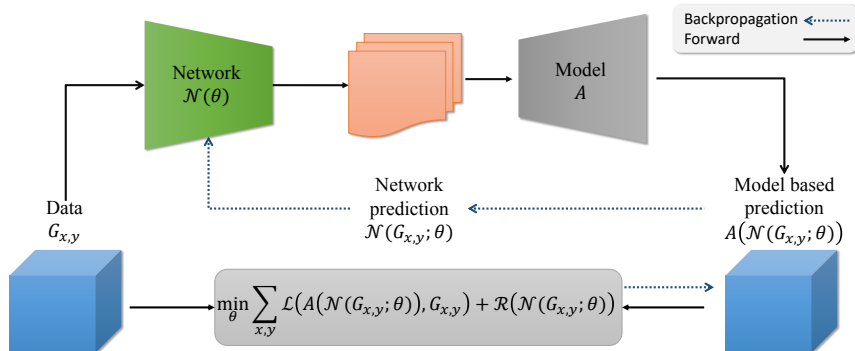

**Figure 1.** Deep optimization prior approach is reparametrizing  $u_{x,y}$  by a network  $\mathcal{N}$  in combination with the model-based autoencoder.

## 2 Deep Optimization Prior

The concept of *deep optimization prior* (DOP) is to reparameterize the unknown (image) variable  $u_{x,y}$  in non-convex optimization problems of the form (2) by the prediction of a neural network  $\mathcal{N}$  via  $u_{x,y} = \mathcal{N}(G_{x,y}; \theta)$  for network parameters. Besides from the data term, a regularization term for THz model parameter estimation can be applied, where the regularization improves the THz parameter estimation in the case of individual pixel failure, i.e. shot noise, and yields:

$$\min_{\theta} \sum_{x,y} \|A(\mathcal{N}(G; \theta)_{x,y}) - G_{x,y}\|_2^2 + \lambda \|\nabla \mathcal{N}(G; \theta)_{x,y}\|_1, \quad (3)$$

As illustrated in Fig. 1, this approach is minimizing the loss function  $\mathcal{L}$  as an optimizer during the unsupervised *training* procedure, which is different to the unsupervised *training-then-prediction* approach proposed by [7].

The model-based autoencoder [7] allows unsupervised learning of measurement data by resembling an autoencoder with a learnable network based encoder and a physical model-based decoder, and is, therefore, able to deal with measurement-specific distortions. However, during the per-pixel learning phase in [7], the lateral neighborhood information is not considered. Therefore, the 3D model-based autoencoder architecture in Fig. 2 allows unsupervised learning on the THz measurement data using this approach for a lateral spatial coupled optimization. In contrast to the 1D single pixel autoencoder [7], this network-based reparameterization allows spatial coupling even though the THz model (1) is independent in the lateral spatial domain. This U-net network architecture is computational extremely more efficient than CNN architecture, while it couples pixels in large lateral spatial regions, which is an important feature in this application.

The evaluation in [2] showed that this deep optimization prior approach finds a better minima than classical optimizers (Table 1), estimates model parameters in low SNR levels (Fig. 3) and robustly reconstructs parameters in shot noise situations. More details of the experiments can be found in [2].

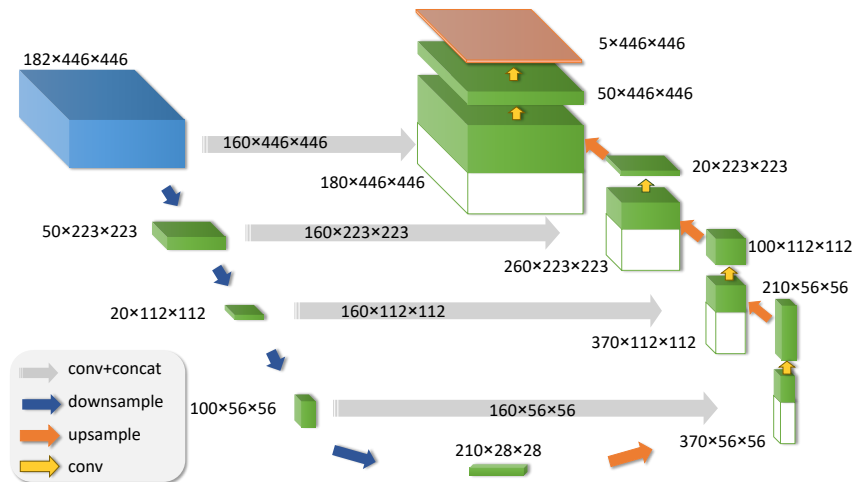

**Figure 2.** U-net architecture of network  $\mathcal{N}$  (example for 182 channels with  $446 \times 446$  pixels) start from the data tensor  $G_{x,y}$  to the desired parameter  $u_{x,y} = \mathcal{N}(G_{x,y}; \theta)$ .

**Table 1.** Comparison of average  $\ell^2$ -squared loss in (2) using measurement dataset by classical optimizers to the Deep Optimization Prior (DOP) approach. The full details of experiments can be found in [2].

Average Normalized Loss ( $\times 10^{-6}$ )		
Optimizer	AdamW	DOP
MetalPCB+AWGN at PSNR Level		
Opt. LR	0.001	0.01
-20dB	36100.08	<b>30871.59</b>
-10dB	7380.64	<b>3271.89</b>
0dB	965.00	<b>400.09</b>
10dB	135.92	<b>111.22</b>

### 3 Deblurring on the THz model parameter image

In this section, we compare the resolution enhancement by the deep optimization prior (DOP) approach to the per-pixel curve fitting approach using the THz image enhancement methodology in [1].

#### 3.1 Experimental Setup

We evaluate the deblurring result on the *MetalPCB+AWGN* datasets from [2], which are based on a measured FMCW THz image datasets using a resolution target. The datasets are synthetically added with an Additive White Gaussian Noise (AWGN) at PSNR noise level from  $-20\text{dB}$  to  $10\text{dB}$  by simulation respectively.

For the comparison of the per-pixel curve fitting optimizer, we choose the AdamW [8] op-



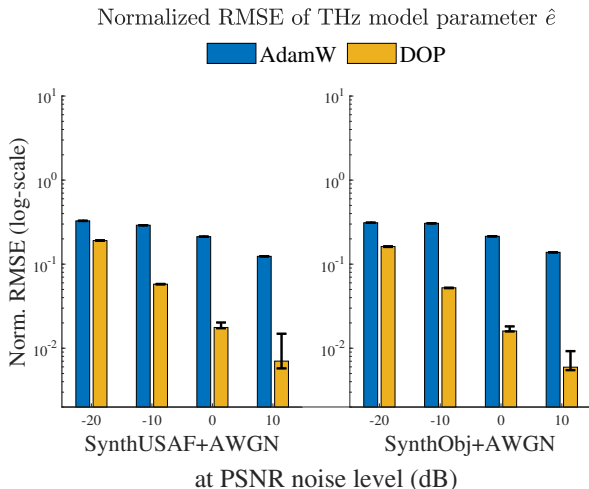

**Figure 3.** Comparison of RMSE of model parameter  $\hat{\epsilon}$  using synthetic datasets at AWGN noise level from  $-20$  to  $10$ dB. The full details of the experiments can be found in [2].

timizer adopted in [2] instead of the Trust-Region Algorithm [9] in [1] to be able to properly compare with the DOP approach in [2] by taking the same optimizer and hyperparameters.

For the deconvolution method, we apply one of the modern blind deblurring method by Xu et al. [5], [6], which had the best resolution enhancement performance in the evaluation of [1].

For the evaluation parameter, we reconstruct the intensity image according to the method in [1, Section 7.2.2], while the lateral resolution is defined as the finest dimension that can resolve an target with 3dB intensity difference. In this section, we evaluate the vertical and horizontal intensity difference of each resolution group of the resolution target (from  $4000\mu\text{m}$  to  $280.6\mu\text{m}$ ). The vertical and horizontal resolution is then determined as the first minimum dimension that obtained at 3dB crossing of intensity difference. By repeating to determine the resolution for each noise level, we compare the lateral resolution improvement of the optimization approaches using different AWGN noise level (see Table 2). Note that in practise the intensity difference can decrease non-homogeneously (see example in Fig. 5). Therefore, we additionally determine the range of uncertainty (see Table 2) that indicates the difference between the first and last noise levels obtaining a 3dB crossing intensity difference.

### 3.2 Evaluation

Fig. 4 shows the intensity images by the original datasets (first row), the AdamW estimation (second row), the DOP estimation (third row), and respective deblurring images (last two rows) using *MetalPCB* datasets at AWGN noise level from  $-20$ dB to  $10$ dB. Note, that the original datasets intensity image is extracted by the same methodology in [1, reference intensity in Section 7.2.2], which is the signal intensity of the *MetalPCB+AWGN* datasets

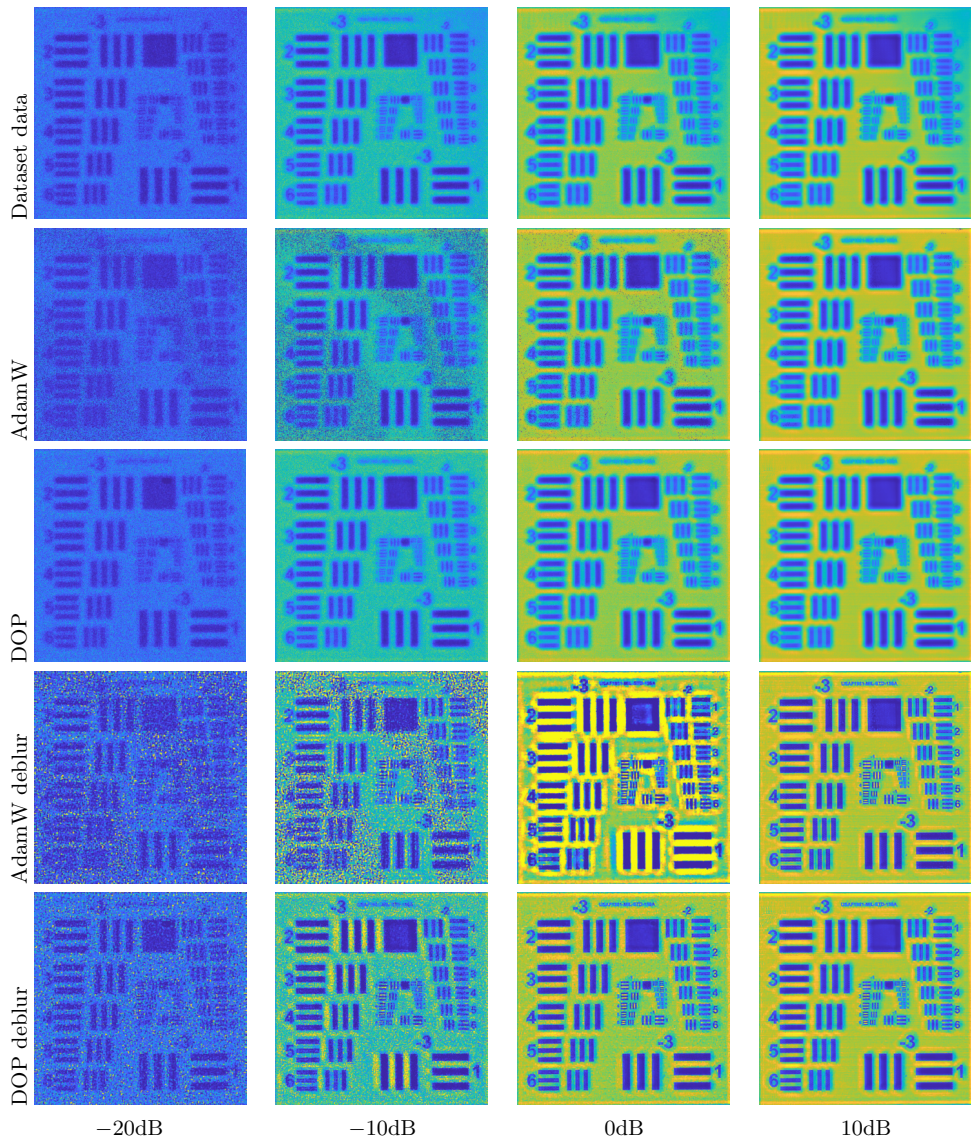

**Figure 4.** Comparison of THz intensity images by original dataset data (first row), the per pixel AdamW optimizer approach (second row) and the DOP approach (third row) using MetalPCB datasets at AWGN noise level from -20dB to 10dB. Images by AdamW and DOP (last two rows) approaches are deblurred by blind deconvolution method from Xu [5], [6].

data at the center of sampling window.

By visual comparison of the intensity images of AdamW and DOP estimation, we observe that DOP approach obtains less outliers for very low SNR level, i.e., -20dB and -10dB. These outliers are more significantly observable after the deblurring procedure, which makes

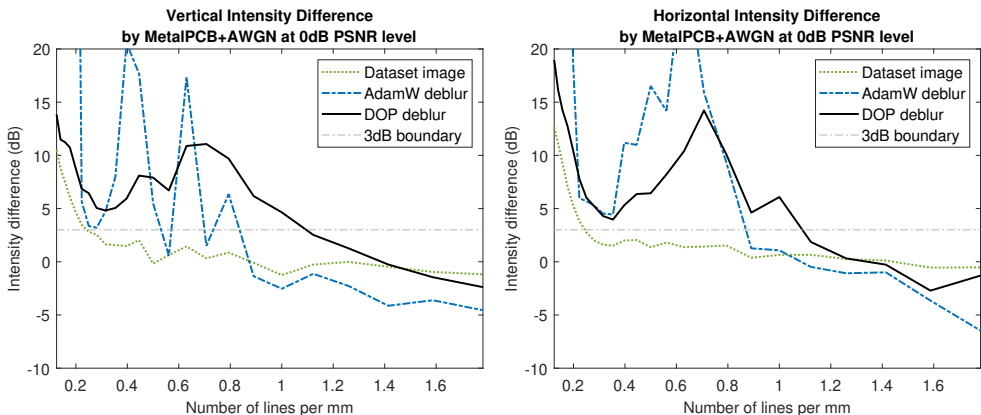

**Figure 5.** Comparison of the vertical and horizontal intensity difference using *MetalPCB* datasets at 0dB AWGN noise level for each resolution target group from  $4000\mu\text{m}$  to  $280.6\mu\text{m}$ .

the deblurred DOP intensity image having a better quality than the deblurred AdamW intensity image because of the robustness of DOP estimation.

Fig. 5 plots the vertical and horizontal intensity difference for each resolution target group from  $4000\mu\text{m}$  to  $280.6\mu\text{m}$ , using the *MetalPCB* datasets at 0dB AWGN noise level as an example.

As a higher intensity difference represents a better ability to resolve a resolution target, both deblurred AdamW and DOP intensity images out-perform the original dataset image, while the deblurred DOP intensity image obtains a more stable intensity difference than the deblurred AdamW image. By comparing the 3dB crossing dimension obtained by both deblurred images, the DOP approach enhances the performance of deblurring method because of the robustness of model parameter estimation.

**Table 2.** Comparison of vertical and horizontal resolution using *MetalPCB* datasets at AWGN noise level from -20 to 10dB. The range of uncertainty is shown in parentheses. The best (lower is better) optimizers are highlighted.

Vertical Resolution in $\mu\text{m}$ (range of uncertainty)			
SNR	Dataset image	AdamW deblur	DOP deblur
-20dB	2282.62 ( -0.0)	2808.23 (-2027.3)	<b>2223.05 (-1454.1)</b>
-10dB	2088.29 ( -0.0)	2318.77 (-1712.9)	<b>585.87 ( -0.0)</b>
0dB	2066.73 ( -0.0)	944.45 ( -344.4)	<b>457.60 ( -0.0)</b>
10dB	2022.34 ( -0.0)	<b>535.28 ( -0.0)</b>	568.10 ( -99.6)
Horizontal Resolution in $\mu\text{m}$ (range of uncertainty)			
SNR	Dataset image	AdamW deblur	DOP deblur
-20dB	<b>2208.92 ( -0.0)</b>	2633.74 ( -0.0)	<b>2288.36 (-1539.3)</b>
-10dB	2099.83 ( -0.0)	1808.98 (-1076.7)	<b>1048.52 ( -447.1)</b>
0dB	2054.55 ( -0.0)	575.93 ( -0.0)	<b>460.14 ( -0.0)</b>
10dB	2055.73 ( -0.0)	573.10 ( -80.8)	<b>444.31 ( -0.0)</b>

Table 2 compares the vertical and horizontal resolution for the AWGN noise level from  $-20\text{dB}$  to  $10\text{dB}$  respectively, and the range of uncertainty is shown in parentheses.

As we can see from the table, the DOP approach is generally improving the deblurring method with respect to the resolution enhancement ability. The improvement of the DOP approach over the AdamW approach is mainly due to the enhanced robustness of model parameters estimation, which obtains a shorter range of uncertainty except for the vertical resolution at  $10\text{dB}$  and the horizontal resolution at  $-20\text{dB}$  noise level.

## 4 Summary

In this paper, we propose the combination of the deep optimization prior approach [2] and the THz image deblurring [1], and evaluate the impact of combining both methods to the lateral resolution improvement for FMCW THz imaging. We apply the modern blind deconvolution method such as Xu et al. [5], [6] to the result of the THz parameter estimation by the deep optimization prior approach [2] and the per-pixel curve fitting approach [1], and evaluate the lateral resolution enhancement. Experiments demonstrate that the deep optimization prior approach improves the lateral resolution enhancement because of the robust reconstruction of model parameters in low SNR noise level.

## References

- [1] T. M. Wong, M. Kahl, P. Haring Bolivar, and A. Kolb, “Computational image enhancement for frequency modulated continuous wave (fmcw) thz image,” *J. Infrared, Millimeter, and Terahertz Waves*, vol. 40, no. 7, pp. 775–800, 2019.
- [2] T. M. Wong, H. Bauermeister, M. Kahl, P. H. Bolivar, M. Möller, and A. Kolb, “Deep optimization prior for thz model parameter estimation,” in *WACV*, 2022, pp. 3811–3820.
- [3] D. Ulyanov, A. Vedaldi, and V. Lempitsky, “Deep image prior,” in *CVPR*, 2018, pp. 9446–9454.
- [4] O. Ronneberger, P. Fischer, and T. Brox, “U-net: Convolutional networks for biomedical image segmentation,” in *Int. Conf. on Med. Image Comput. Computer-assisted Intervention*, Springer, 2015, pp. 234–241.
- [5] L. Xu and J. Jia, “Two-phase kernel estimation for robust motion deblurring,” in *European conference on computer vision*, Springer, 2010, pp. 157–170.
- [6] L. Xu, S. Zheng, and J. Jia, “Unnatural l0 sparse representation for natural image deblurring,” in *Proceedings of the IEEE Conference on Computer Vision and Pattern Recognition*, 2013, pp. 1107–1114.

- 
- [7] T. M. Wong, M. Kahl, P. Haring Bolivar, A. Kolb, and M. Möller, “Training auto-encoder-based optimizers for terahertz image reconstruction,” in *GCPR*, Springer, 2019, pp. 93–106.
  - [8] I. Loshchilov and F. Hutter, “Decoupled weight decay regularization,” in *ICLR*, 2018.
  - [9] T. F. Coleman and Y. Li, “An interior trust region approach for nonlinear minimization subject to bounds,” *SIAM Journal on optimization*, vol. 6, no. 2, pp. 418–445, 1996.



# Light-Weight Learning-Based Depth Estimation From A Single Image

Zekarias Negese<sup>1</sup>, Hartmut Bauermeister<sup>2</sup>, Michael Moeller<sup>2</sup>, Emanuele Rodolà<sup>1</sup>, Zorah Lähler<sup>2</sup>

<sup>1</sup> Sapienza Università di Roma, Dipartimento di Informatica, Via Salaria 113, 00198 Roma, Italy  
znege@uniroma1.it, rodola@di.uniroma1.it

<sup>2</sup> University of Siegen, Department für Elektrotechnik und Informatik, Hölderlinstr. 3, 57076 Siegen, Germany  
{hartmut.bauermeister, michael.moeller, zorah.laehner}@uni-siegen.de

**Abstract.** *Estimating the depth of a scene from a single image is impossible due to scale ambiguity, but recent deep learning approaches have demonstrated to produce faithful estimates anyways by learning the typical scale of objects from implicit clues in the scene. In this paper, we present a new encoder-decoder architecture for single image depth reconstruction that yields state-of-the-art results with considerably less parameters than competitors. Our architecture incorporates a modified inception module tailored to our application which allows us to use a relatively lightweight architecture with fewer learnable parameters than state-of-the-art single image depth reconstruction networks. We train and evaluate on the known NYU RGB-D benchmark dataset, and show generalization of our method by evaluating the pretrained NYU model on the iBims dataset. Our results are in the same order of magnitude as state-of-the-art competitors, even though we trained on a different resolution.*

**Keywords.** Monocular depth, deep learning, CNNs, efficient deep learning, inception module

## 1 Introduction

Classical approaches to capture the geometry of a scene require at least two viewpoints (e.g. a stereo [1] or light field camera [2]), a sequence of images, such as focal stacks to extract depth clues from the depth of field in depth-from-focus (e.g. [3]) and depth-from-defocus (e.g. [4]) approaches, or special recording techniques with active lighting such as structured light or time-of-flight cameras. Applications of such techniques range from image refocusing, over the initialization of 3D reconstruction algorithms, e.g. in autonomous driving, to augmented reality. However, estimating the depth of a scene from only a single RGB image is an inherently ill-posed problem, which – from a purely physical perspective – cannot distinguish between the size of an object and its distance to the camera. To solve this problem, prior knowledge of typical object sizes as well as blur focus at different depth levels can give meaningful clues about the scene composition and depth. For a certain type of natural images, numerous recent works have exploited deep learning techniques to still make faithful predictions, demonstrating that implicit clues of the size of everyday objects are often sufficient to still provide accurate estimates, see Section 2.

At the same time, more powerful hardware allowed training incredible complex deep learning models with ever improving results. Complex models with a huge amount of parameters are able to learn very complicated functions but naturally also require a larger amount of memory and computing power, even at inference time. This is often not feasible on smaller or cheaper hardware that is used, for example, in many mobile applications and consumes, sometimes unnecessary, large amounts of electricity. The purpose of this paper is to introduce a network architecture for monocular depth estimation which balances network size and training time without sacrificing too much accuracy or overfitting to specific training data.

To this end, we propose an encoder-decoder network for monocular depth estimation using inception style layers [5]. Our architecture performs on-par with state-of-the-art algorithms while being comparably light-weight, i.e. having less trainable parameters, and is generalizable to different datasets and resolutions.

**Contributions.** We propose a novel encoder-decoder architecture for depth from a single RGB image using inception blocks. Our architecture optimizes the trade-off between having few parameters for efficient training and inference but still resulting in good accuracy. The multi-scale property of this block as well as its separation of channel and spatial dimensions lead to convincing performance on the NYU dataset [6]. In addition to yielding accurate results, our architecture has considerably fewer trainable parameters than direct competitors which makes it more efficient in both training as well as inference. We show that our results are generalizable to different resolutions and datasets by evaluating the pretrained NYU model on the iBims dataset [7].



## 2 Related Work

In this section, we review existing work for monocular depth reconstruction that is directly related to our method (Section 2.1), as well as work about increasing the efficiency of neural networks (Section 2.2). We refer the interested reader to [8] for an in-depth overview of deep learning based monocular depth estimation.

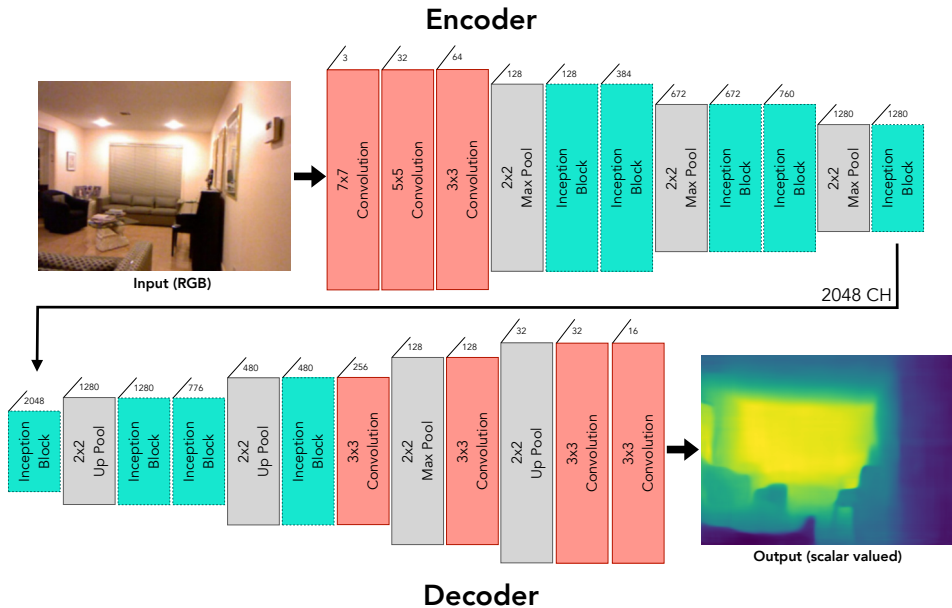

**Figure 1. The proposed model architecture.** We employed an inception style encoder-decoder network. The layers with red colors indicate basic spatial convolution, while the layers with cyan color indicate inception layers (also see Figure 2). The layers with gray color indicate max-pooling layers in the encoder part and up-sampling layers in the decoder layer. The number over each block indicate the input feature dimension. Exact details of the architecture are described in Table 5.

### 2.1 Monocular Depth

Predicting depth from a single image is an ill-posed problem in which the influence of scale and distance to the camera cannot be completely separated. As a result, the majority of literature about depth estimation considers settings with at least stereo vision [9], or coming directly from specialized hardware [10]. However, reasonable estimations can be made with semantic prior knowledge about scenes. With the rise of deep learning, using huge amount of training data became feasible and, as a result, made solving this problem possible. One of the first major works in this direction was [11]. They proposed a single image method for depth estimation by training two consecutive CNNs. The first CNN learns coarse global information based on the whole image and then the second deep network refines it by

learning local cues. [12] also used a two stage strategy where they first categorized the RGB image into different RGB ranges using a scene understanding module, and then in the second stage, train a network on the images with a specific depth range. Similar works on depth estimation from a single image [13]–[18] have been proposed based on CNNs with different architectures and loss functions. [19] proposed to train an encoder-decoder CNN where the encoder part employs DenseNet-169.

Other directions include more geometric information directly into the network architecture. [20] described a depth estimation technique using local planar guidance layers placed at multiple stages in the decoding phase of an encoder-decoder network. [21] proposed a monocular depth estimation method with stable geometric constraints from a global perspective to take long-range constraints into account, termed as virtual normals. [22] proposed a novel technique called attention based context aggregation network (ACAN). They adopt a deep residual network [23] where dilated convolutions are used to maintain the spatial scale. [24] proposed SharpNet, a method that predicts an accurate depth map from given a single input color image, with particular attention to the reconstruction of occluding points, by constraining the depth estimation and occluding contours during model training.

Current state-of-the-art is able to produce highly accurate depth maps but at the price of very complex networks with long training times (see Table 4). Our work is also a CNN encoder-decoder, but instead of explicitly including expensive geometric priors into the architecture we focus on the higher priority of cross-channel relationships, as opposed to spatial information in normal convolutions, by using inception blocks [5]. We show that this prior is powerful enough for monocular depth to achieve results on par with state-of-the-art using considerably less parameters than previous methods. Chen et al. [25] already build a network with inception blocks for this problem with great success in reducing the parameters but at the cost of accuracy.

## 2.2 Efficient Networks

With more powerful GPUs available in the last years, it became possible to train larger and larger networks with some methods taking several days to train architectures with billions of parameters [26]. While this often leads to superior results, the energy consumption rises and some hardware can only deploy smaller networks [27]. This is especially important for mobile and IoT applications where both are limited. One of the first major papers to tackle this was [28]. The method uses depth-wise separable convolutions to manage the size of the network, and lets the user adjust the performance-complexity ratio through hyperparameters. Many works followed up on this, putting the focus mainly in classification on mobile applications [29]–[31].

[16] worked on reducing the complexity of monocular depth estimation architectures. While producing a very small network with fast inference time, their accuracy is not on-par with state-of-the-art results. [32] proposed a monocular depth estimation for IoT devices which are normally even more restricted than mobile hardware. Therefore, this work focuses on energy consumption instead of accuracy, and only works on restricted image resolutions. Our method goes in the direction of [33] but for monocular depth instead of general convolutional nets: reducing the complexity of the network without a specific hardware in mind

while achieving state-of-the-art results.

### 3 Method

In this work, we employ an encoder-decoder CNN architecture with inception blocks. The architecture is explained in detail in the following sub-sections. The entire network architecture is shown in Figure 1 and Table 5 in the supplementary. Instead of an encoder-decoder network with basic convolutional layers, an inception-like encoder-decoder network is used to get the advantage of multi-level feature extraction in both spatial and cross-channel dimensions.

The inception blocks are a key feature that allow our architecture to consistently perform on-par with state-of-the-art methods while using considerably fewer parameters than any competitor. Due to a collection of  $1 \times 1$  convolutions (see Section 3.1), inception blocks put more weight on cross-channel information than on spatial relations. We claim that this induces a more meaningful and stronger network prior for the task of depth prediction on natural images than existing models, and this is the reason for our good performance with a smaller network architecture.

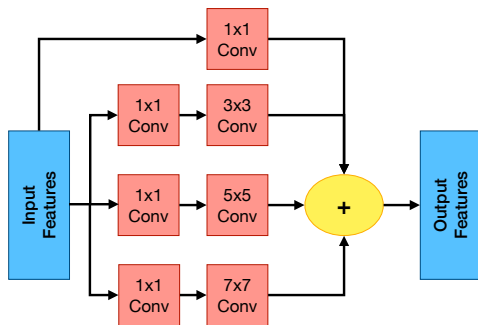

**Figure 2. Inception block.** Each  $k \times k$  convolution with  $k \geq 2$  is preceded by a  $1 \times 1$  convolution to make the model efficient while having a deeper network. The final results are concatenated into the output feature. This is a slightly adjusted version of the original inception blocks [5] without a pooling operation as it was already used in [25].

#### 3.1 Inception Blocks

We make use of the so-called inception blocks introduced in [5] for classification and object detection. Inception blocks introduce  $1 \times 1$  convolutions before the higher dimensional convolutions ( $3 \times 3$ ,  $5 \times 5$  in the original paper) to reduce the dimensionality of the feature maps. This densifies the representation and, as a result, reduces the computational cost because smaller feature maps cover the the same information. The needed computational cost, i.e. the number of multiplications, is reduced by an order of magnitude for  $k \times k$  kernels with  $k > 1$ , and allows to use deeper networks without an efficiency loss. See Figure 2 for

the structure of inception blocks. Using this, [5] managed to improve the state-of-the-art accuracy on ImageNet without a huge increase in complexity of the network.

## 3.2 Method

In our approach, we use the inception blocks in an encoder-decoder architecture to calculate depth maps from single images. The entire architecture can be seen in Figure 1. The inception structure leads to multi-level feature extraction in the image without increasing the complexity too much. This is the reason why we can achieve high accuracy with the least amount of parameters in our experiments (see Section 4.5). Additionally, inception blocks include cross-channel correlations independently of the spatial dimension in the  $1 \times 1$  reduction. This is an advantage over many previous works where convolutions cover spatial and channel dimensions simultaneously without separating the information.

We also tested our architecture with the suggested auxiliary networks used with the inception blocks in [5]. However, we found that the network performs better without, and, additionally, has a lower number of parameters.

### 3.2.1 Network Architecture.

We optimized our network architecture to use as few parameters as possible without compromising the performance. As a result we use an adjusted inception block without max pooling (see Figure 2), and input the RGB image in half the resolution of the desired output depth resolution, as both did not have a significant influence on the results. Our final model architecture is comprised of 3 convolutional layers and 5 inception blocks in the encoder, and 4 inception blocks followed by 4 convolutions in the decoder, both with pooling operations in between. See Figure 1 for the full architecture.

**Inception Blocks.** We adjusted the original inception blocks from [5] slightly to fit this application better. Instead of convolutions up to kernel size  $5 \times 5$ , our inception block contains an additional convolution of size  $7 \times 7$ . The larger kernel size leads to more global feature information that helps with a consistent depth output. Each higher dimensional convolution is preceded by the inception block typical  $1 \times 1$  convolution. We removed the max pooling of the inception block in [5] because it did not improve the results but increased the number of parameters. We show the structure of our inception block in Figure 2.

**Convolutions.** Additional to inception blocks, we used 3 basic convolutional layers in the lower stage of the encoder and 4 basic convolutional layers in the last stage of decoder part. Each basic convolutional layer is comprised of a convolution, a batch normalization, and a ReLU operation. Padding size of 1, 2, and 3 are used in  $3 \times 3$ ,  $5 \times 5$ ,  $7 \times 7$  convolutions, respectively.

**Pooling.** Three max-pooling layers, with kernel size  $2 \times 2$  and stride 2, are used in the encoder part to reduce the spatial dimension of features by preserving the most important feature information. In the decoder, 4 bi-linear up-sampling layers with scale factor 2 are used to upscale the dimension back to the image resolution for the final predicted depth.

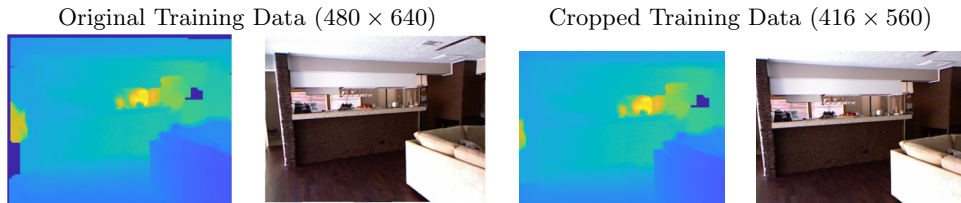

**Figure 3.** Comparison of original and cropped training data in the NYU dataset. The zero values along the boundaries vary within the training set and hinder efficient optimization.

## 4 Experiments

We show the performance of our architecture on the NYU and iBims datasets (Section 4.1) against several established monocular depth estimation methods. We compare the quantitative performance (Section 4.4) as well as the network size and training time (Section 4.5).

### 4.1 Datasets

We evaluate on the NYU v2 (Section 4.1.1) and iBims-1 (Section 4.1.2) datasets.

#### 4.1.1 NYU v2 Dataset

In our experiments, we used the publicly available NYU Depth v2 RGB-D dataset [6]. This dataset contains 464 video sequences of 26 different indoor scenes recorded with a Microsoft Kinect RGB-D camera with over 400k frames in total. It contains two sets of  $480 \times 640$  images, which are labeled (pre-processed) and raw sets. The labeled dataset accounts for 1449 pairs of RGB-D images which were randomly selected from the raw dataset. The second set is the raw dataset, which contains raw images (RGB and depth) and accelerometer dumps as produced by the Kinect camera. This set is unprocessed and with many missing depth pixels. Hence, we pre-processed and aligned the raw depth image using the acceleration data and tools provided with the dataset. The test images were randomly selected from the labeled images. The rest of the labeled images were added to training set. Then, the validation set was randomly selected from the whole training set.

We synchronized the RGB and depth images based on the timestamps of the captured frames. To increase the size and diversity in the training set, we augmented the training set with horizontally flipped versions which are meaningful for indoor scenes. The augmentation was done off-line as preprocessing. In total, we used 194K images (after augmentation) for training, 654 images for validation, and 654 images for testing. In our experiments comparing to existing works (Table 1), we have used the train-test split proposed by the dataset.

**Cropped Training Data** Due to the slight offset of depth and RGB frames and hardware, the training data contains varying amounts of missing boundaries. They are quite irregular, and hindered our network from training efficiently. To overcome this, we cropped the training set at the boundaries to a smaller resolution, namely  $416 \times 560$  pixels. See Figure 3



**Figure 4. Output of our model on NYU RGB-D dataset.** The first row shows the input RGB image, the second row shows the ground truth depth image, and the last row shows the estimated depth image of our method.

for a side-by-side comparison of the original and cropped versions. This improved our results and lowered the time and memory needed for training significantly. Notice that although we train on a lower resolution, our architecture is fully convolutional and, therefore, applicable to higher resolutions as well. We show the evaluation of both resolutions in Section 4.4.

### 4.1.2 *iBims-1 Dataset*

Additionally, we evaluate on the iBims-1 dataset [7]. This dataset contains 100 RGB-depth pairs from 10 different indoors scenes, and contains more in-depth ground-truth labeling and evaluation metrics than NYU. It is meant to further evaluate models trained on different datasets, especially NYU, showing generalization capability and providing more detailed metrics. All images are  $480 \times 640$  pixels, with ground-truth depth, masks annotating invalid and missing pixels, as well as some semantic segmentation masks and plane estimations that are used for evaluation.

## 4.2 Implementation and Training

Our depth estimation network is implemented using PyTorch using Adam as the optimizer. The root mean squared error (RMSE) is used as the loss function. All models were trained with a batch size of 4.

The learning rate starts as 0.001 and is reduced by  $10^{-1}$  as soon as the error on the validation set does not decrease anymore. This is also used as a stopping criterion. Table 3 shows the improvement of the RMS in each epoch with the corresponding learning rate. The training takes around 15 epoches and one epoch takes about 200 minutes. We choose the model with the best validation error as the final model. All experiments were done on a GeForce GTX GPU with 12 GB memory.

## 4.3 Evaluation Measures

We use the following four standard metrics to compare the performance in our experiments. Here,  $y_i$  denotes the  $i^{\text{th}}$  pixel values in the ground-truth depth image  $y$ ,  $\hat{y}_i$  is the  $i^{\text{th}}$  pixel value in the predicted depth image  $\hat{y}$ , and  $N$  is the total number of pixels of the depth image.

**Root mean squared error:** RMSE measures the normalized distance between the predicted value and the actual value. It is defined as follows:

$$\text{rms} = \sqrt{\frac{1}{N} \sum_{i=1}^N (y_i - \hat{y}_i)^2}$$

**Average relative error:** RE is computed by dividing the absolute error by the magnitude of the ground-truth value:

$$\text{rel} = \frac{1}{N} \sum_{i=1}^N \frac{|y_i - \hat{y}_i|}{y_i}$$

**Average  $\log_{10}$  error:** This is the mean of  $\log_{10}$  scaled errors which weights down outliers

**Table 1. Quantitative comparison on the NYU v2 RGB-D dataset.** The first column shows the different methods for depth prediction. The next six rows show the standard metrics used to compare these methods. The up-arrow indicates that the largest value is the best, while the down-arrow indicates that the lowest value is the best. The bold values indicate the best model on that specific metric. The values for the other methods are taken from their respective papers. While we outperform on the resolution we trained on, we still get on-par accuracy on the original resolution that our network never saw during training.

Method	$\delta_1 \uparrow$	$\delta_2 \uparrow$	$\delta_3 \uparrow$	rel $\downarrow$	rms $\downarrow$	$\log_{10} \downarrow$
Lee et al. [20]	0.885	0.978	0.994	0.110	0.392	0.047
Wei et al. [21]	0.875	0.976	0.994	0.108	0.416	0.048
Alhashim et al. [19]	0.895	0.980	0.996	<b>0.103</b>	0.390	<b>0.043</b>
Eigen et al. [11]	0.611	0.887	0.971	0.215	0.907	0.285
Xu et al. [14]	0.811	0.954	0.987	0.121	0.586	0.052
Laina et al. [17]	0.811	0.953	0.988	0.127	0.573	0.055
Hao et al. [13]	0.841	0.966	0.991	0.127	0.555	0.053
Li et al. [34]	0.788	0.958	0.991	0.143	0.635	0.063
Bhat et al. [35]	<b>0.903</b>	<b>0.984</b>	<b>0.997</b>	<b>0.103</b>	<b>0.364</b>	0.044
Chen et al. [25]	-	-	-	0.34	1.10	0.38
<b>Ours</b> (original resolution)	0.843	0.960	0.990	0.126	0.388	0.051
<b>Ours</b> (training resolution)	<b>0.937</b>	<b>0.989</b>	<b>0.997</b>	<b>0.076</b>	<b>0.253</b>	<b>0.031</b>

in the solution:

$$\log_{10} = \frac{1}{N} \sum_{i=1}^N |\log_{10}(y_i) - \log_{10}(\hat{y}_i)|$$

**Threshold accuracy:** This measures the ratio of samples for which the relative error is below a threshold.

$$\delta_k = \frac{1}{N} \sum_{i=1}^N \sigma_i, \quad (1)$$

$$\sigma_i = \begin{cases} 1 & \text{if } \max\left(\frac{y_i}{\hat{y}_i}, \frac{\hat{y}_i}{y_i}\right) < T^k, \\ 0 & \text{otherwise.} \end{cases} \quad (2)$$

In our experiments, we use  $\delta_1, \delta_2, \delta_3$  and  $T = 1.25$  for the evaluation. The first three measure the error, so values close to zero are better. Threshold accuracy is valued between 0 and 1 with 1 being the optimal value.

#### 4.3.1 iBims Metrics

As an enrichment to the the standard metrics, the iBims dataset offers a collection of additional metrics based on the additional ground-truth annotation in the dataset. We will give a short overview of the measures here, please consult [7] for the exact formulas.



**Table 2. Quantitative comparison on the iBims-1 dataset.** The first six columns show the metrics as in Table 1, the next six are iBims specific, see Section 4.3. The up-arrow indicates that the largest value is the best, while the down-arrow indicates that the lowest value is the best. The bold values indicate the best model on that specific metric. The values for the other methods are taken from [7]. All of the methods were trained on NYU. Although the winner in the standard metrics is clear, the newly introduced metrics for iBims show varying results.

Method	$\delta_1 \uparrow$	$\delta_2 \uparrow$	$\delta_3 \uparrow$	rel $\downarrow$	rms $\downarrow$	log $\downarrow$	$\epsilon_{PE}^{plan} \downarrow$	$\epsilon_{PE}^{orie} \downarrow$	$\epsilon_{DDE}^{acc} \downarrow$	$\epsilon_{DDE}^{comp} \downarrow$	$\epsilon_{DDE}^+ \downarrow$	$\epsilon_{DDE}^- \downarrow$
Eigen [11]	0.36	0.65	0.84	0.32	1.55	0.17	6.65	25.62	5.48	70.31	25.71	<b>2.23</b>
Laina [17]	0.50	0.78	0.91	0.25	1.20	0.13	<b>5.71</b>	<b>18.49</b>	6.89	40.48	15.91	2.43
Li [34]	<b>0.59</b>	<b>0.85</b>	<b>0.95</b>	<b>0.22</b>	<b>1.07</b>	<b>0.11</b>	6.22	20.17	<b>3.68</b>	<b>36.27</b>	12.49	3.38
<b>Ours</b>	0.43	0.74	0.89	0.29	1.37	0.14	11.66	18.80	4.24	52.46	<b>2.14</b>	22.47

**Planarity and Orientation:** Based on ground-truth annotated major planes in the depth data, the values  $\epsilon_{PE}^{plan}$  and  $\epsilon_{PE}^{orie}$  measure how planar the result is in comparison to the ground-truth and how close the orientations are to each other, respectively.

**Location Accuracy of Depth Boundaries:** The next metric measures how well boundaries in the depth maps are preserved by comparing detected edges.  $\epsilon_{DDE}^{acc}$  and  $\epsilon_{DDE}^{comp}$  describe the accuracy of existing edges as well as the completeness of present edges, respectively.

**Directed Depth Error:**  $\epsilon_{DDE}^+$  and  $\epsilon_{DDE}^-$  measure the percentages of pixels that were estimated as too far or too close, respectively.

#### 4.4 Comparison with Existing Methods

We evaluate the quantitative performance of our methods against prior works in the same setting using the performance measures from Section 4.3.

##### 4.4.1 NYU v2

We evaluate on both the original resolution of the NYU dataset as well our training resolution (see Section 4.1), using the same pretrained model for both. On the training resolution, our method performs extraordinarily well, outperforming the competitors in all measures (which are all normalized wrt. resolution). On the original resolution, our results are still close to state-of-the-art methods although this resolution was never seen during training. Notice that the NYU test set does not suffer from the same boundary issues the training set has. We are convinced that our architecture would perform even better on the original with a slightly adapted training procedure overcoming the missing boundary problems. The exact results are reported in Table 1. Qualitative results can be seen in Figure 4.

##### 4.4.2 iBims-1

On the iBims, dataset we compare to three methods in the benchmark of [7]. Since this dataset is rather new, not that many methods have been evaluated on it. All methods were pretrained on NYU and not finetuned to iBims. While the winner in the standard metrics is clear on this dataset, the results for the more detailed metrics of the dataset are mixed. Again, our method is not far off the state-of-the-art although our network is a lot smaller and was trained on a different resolution. The exact results are reported in Table 2.

**Table 3. The RMSE on the training and validation set as well as the learning rate (LR) at each epoch.** The learning rate is reduced by an order of magnitude each time the error on the validation set does not decrease anymore. The final stop happens after reducing the learning rate twice without improvement.

Epoch	Train RMS	Val RMS	LR
1	<b>0.889*</b>	<b>0.604*</b>	<b>0.001</b>
2	<b>0.509</b> ↓	<b>0.459</b> ↓	<b>0.001</b>
3	<b>0.390</b> ↓	<b>0.391</b> ↓	<b>0.001</b>
4	<b>0.333</b> ↓	<b>0.341</b> ↓	<b>0.001</b>
5	<b>0.299</b> ↓	<b>0.339</b> ↓	<b>0.001</b>
6	<b>0.277</b> ↓	<b>0.316</b> ↓	<b>0.001</b>
7	<b>0.261</b> ↓	<b>0.293</b> ↓	<b>0.001</b>
8	<b>0.248</b> ↓	<b>0.289</b> ↓	<b>0.001</b>
9	<b>0.239</b> ↓	<b>0.271</b> ↓	<b>0.001</b>
10	<b>0.231</b> ↓	<b>0.281</b> ↑	<b>0.001</b>
11	<b>0.207</b> ↓	<b>0.267</b> ↓	<b>0.0001</b>
12	<b>0.200</b> ↓	<b>0.256</b> ↓	<b>0.0001</b>
13	<b>0.197</b> ↓	<b>0.247</b> ↓	<b>0.0001</b>
14	<b>0.195</b> ↓	<b>0.259</b> ↑	<b>0.0001</b>
15	<b>0.193</b> ↓	<b>0.250</b> ↑	<b>0.00001</b>

Qualitative results can be seen in Figure 5.

#### 4.5 Number of Parameters

We compare our method in another metric, namely the number of trainable parameters in the architecture. This is not directly related to the quantitative performance but the number of parameters is still often critical for its performance and ability to generalize to new inputs. While more parameters can be more expressive, they also need longer for training and more training data to avoid overfitting. In general, a smaller network with the same performance on the a task is preferable.

Our model has  $16.7M$  trainable parameters which is less than all except one competitors, and a third of the next larger architecture. See Table 5 for the details of our architecture. The only network smaller than ours is from [25]. However, as can be seen in Table 1, it falls behind in terms of accuracy in all given measures. The number of parameters of all methods can be found in Table 4. Additionally, and as a result of this, our model also needs fewer iterations before training converges. We train our method for  $218.1k$  iterations compared to [19] and [15] which need  $1M$ ,  $3M$  iterations, respectively. The number of training iterations is directly related to the power consumption needed, and therefore less iterations are preferable.

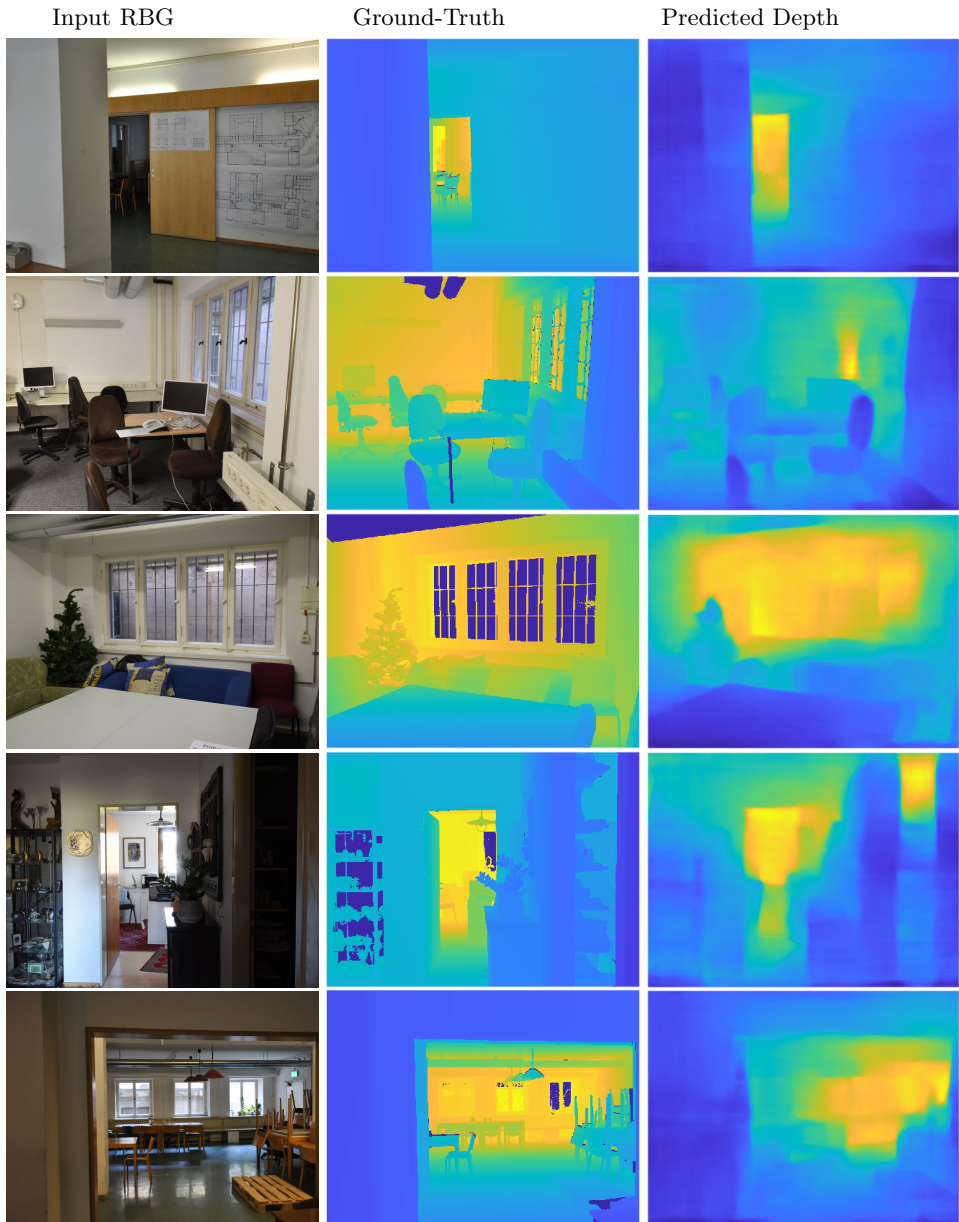

**Figure 5. Output of our model on iBims-1 dataset.** The first row shows the input RGB image (cropped), the second row shows the ground truth depth image, and the last row shows the estimated depth image of our method. Notice that our model was neither trained on this resolution nor the same dataset.

**Table 4. Comparison on the number of learnable parameters.** The numbers are in million. Although our method has the least number of parameters by a large margin, we outperform all other methods in the quantitative evaluations in Table 1.

Method	# of Learnable Parameters
Lee et al. [20]	47.0M
Wei et al. [21]	90.4M
Alhashim et al. [19]	42.6M
Eigen et al. [11]	240.8M
Laina et al. [17]	63.5M
Fu et al. [15]	110.0M
Bhat et al. [35]	78.2M
Chen et al. [25]	5.3M
<b>Proposed model</b>	<b>16.7M</b>

## 5 Conclusion

We presented a novel encoder-decoder architecture with modified inception blocks for the challenging task of monocular depth estimation. The inception blocks focus on finding cross-

**Table 5. Detail of our model architecture.**  $n \times n$  out is the number of output channels after a convolution by  $n \times n$ ,  $n \times n$  red out is the number of output channels after  $1 \times 1$  convolution, which is applied before  $n \times n$  convolution, where  $n$  is the kernel size.

Layer	Kernel size	Output features	1x1 out	3x3 red out	3x3 out	5x5 red out	5x5 out	7x7 red out	7x7 out
Encoder Network									
Basic Conv1	7	32	-	-	-	-	-	-	-
Basic Conv2	5	64	-	-	-	-	-	-	-
Basic Conv3	3	128	-	-	-	-	-	-	-
Max Pool1	2	128	-	-	-	-	-	-	-
Inception1	-	384	64	96	192	32	64	32	64
Inception2	-	672	192	112	256	32	96	64	128
Max Pool2	2	672	-	-	-	-	-	-	-
Inception3	-	760	224	156	312	64	128	32	96
Inception4	-	1280	384	192	384	92	256	64	256
Max Pool3	2	672	-	-	-	-	-	-	-
Inception5	-	2048	768	256	768	96	256	96	256
Decoder Network									
Inception1	-	1280	512	192	384	32	256	64	128
Up Pool1	2	1280	-	-	-	-	-	-	-
Inception2	-	776	224	164	328	64	128	32	96
Inception3	-	480	128	96	224	32	64	32	64
Up Pool2	2	480	-	-	-	-	-	-	-
Inception4	-	256	64	96	128	16	32	16	32
Basic Conv1	3	128	-	-	-	-	-	-	-
Up Pool3	2	128	-	-	-	-	-	-	-
Basic Conv2	3	32	-	-	-	-	-	-	-
Up Pool4	2	32	-	-	-	-	-	-	-
Basic Conv3	3	16	-	-	-	-	-	-	-
Basic Conv4	3	1	-	-	-	-	-	-	-

channel relationships instead of relying on the spatial information of convolutions only or including geometric priors in the architecture as state-of-the-art methods do. We are able to reach close to state-of-the-art results on the NYU v2 dataset while using a considerably lower amount of trainable network parameters. We also showed how our network is generalizable to different resolutions and datasets by training on a smaller resolution on NYU, and evaluated the pretrained NYU model on the iBims dataset. Our method only needs a third of the parameters of the next larger competitor with similar accuracy, and can be trained in less iterations. In addition to speed, the training time is directly correlated to the electricity needed, a measure that cannot be disregarded in light of recent developments of the climate and environment. In future work we plan to directly measure the energy consumption of our methods instead of relying on indirect measurement through training time.

## Acknowledgments

The project was conducted with the support of the Erasmus+ programme of the European Union. Emanuele Rodolà is supported by the ERC grant no. 802554 (SPECGEO).

## References

- [1] P. Kamencay, M. Breznan, R. Jarina, P. Lukac, and M. Zachariasova, “Improved depth map estimation from stereo images based on hybrid method.,” *Radioengineering*, vol. 21, no. 1, 2012.
- [2] W. Zhou, E. Zhou, Y. Yan, L. Lin, and A. Lumsdaine, “Learning depth cues from focal stack for light field depth estimation,” in *2019 IEEE International Conference on Image Processing (ICIP)*, IEEE, 2019, pp. 1074–1078.
- [3] C. Hazirbas, S. G. Soyer, M. C. Staab, L. Leal-Taixé, and D. Cremers, “Deep depth from focus,” in *Asian Conference on Computer Vision (ACCV)*, 2018.
- [4] H. Tang, S. Cohen, B. Price, S. Schiller, and K. N. Kutulakos, “Depth from defocus in the wild,” in *IEEE International Conference on Computer Vision (CVPR)*, 2017.
- [5] C. Szegedy, W. Liu, Y. Jia, et al., “Going deeper with convolutions,” in *Proceedings of the IEEE Conference on Computer Vision and Pattern Recognition (CVPR)*, 2015, pp. 1–9.
- [6] P. K. Nathan Silberman Derek Hoiem and R. Fergus, “Indoor segmentation and support inference from rgb-d images,” in *European Conference on Computer Vision (ECCV)*, 2012.
- [7] T. Koch, L. Liebel, F. Fraundorfer, and M. Körner, “Evaluation of cnn-based single-image depth estimation methods,” in *Proceedings of European Conference on Computer Vision Workshops*, 2018, pp. 31–348.

- 
- [8] C.-Q. Zhao, Q.-Y. Sun, C.-Z. Zhang, Y. Tang, and F. Quian, “Monocular depth estimation based on deep learning: An overview,” *Science China Technological Sciences*, vol. 63, 2020.
  - [9] H. Laga, L. V. Jospin, F. Boussaid, and M. Bennamoun, “A survey on deep learning techniques for stereo-based depth estimation,” *IEEE Transactions on Pattern Analysis and Machine Intelligence (TPAMI)*, 2020.
  - [10] R. Nair, K. Ruhl, F. Lenzen, *et al.*, “Time-of-flight and depth imaging. sensors, algorithms, and applications.,” *Lecture Notes in Computer Science*, vol. 8200, 2013.
  - [11] D. Eigen, C. Puhrsch, and R. Fergus, “Depth map prediction from a single image using a multi-scale deep network,” in *Advances in neural information processing systems*, 2014, pp. 2366–2374.
  - [12] H. Ren, M. El-Khamy, and J. Lee, “Deep robust single image depth estimation neural network using scene understanding.,” in *Proceedings of the IEEE International Conference on Computer Vision Workshops*, 2019, pp. 37–45.
  - [13] Z. Hao, Y. Li, S. You, and F. Lu, “Detail preserving depth estimation from a single image using attention guided networks,” in *2018 International Conference on 3D Vision (3DV)*, IEEE, 2018, pp. 304–313.
  - [14] D. Xu, E. Ricci, W. Ouyang, X. Wang, and N. Sebe, “Multi-scale continuous crfs as sequential deep networks for monocular depth estimation,” in *Proceedings of the IEEE Conference on Computer Vision and Pattern Recognition*, 2017, pp. 5354–5362.
  - [15] H. Fu, M. Gong, C. Wang, K. Batmanghelich, and D. Tao, “Deep ordinal regression network for monocular depth estimation,” in *Proceedings of the IEEE Conference on Computer Vision and Pattern Recognition*, 2018, pp. 2002–2011.
  - [16] D. Wofk, F. Ma, T.-J. Yang, S. Karaman, and V. Sze, “Fastdepth: Fast monocular depth estimation on embedded systems,” in *2019 International Conference on Robotics and Automation (ICRA)*, IEEE, 2019, pp. 6101–6108.
  - [17] I. Laina, C. Rupprecht, V. Belagiannis, F. Tombari, and N. Navab, “Deeper depth prediction with fully convolutional residual networks,” in *2016 Fourth international conference on 3D vision (3DV)*, IEEE, 2016, pp. 239–248.
  - [18] S. Gur and L. Wolf, “Single image depth estimation trained via depth from defocus cues,” in *Proceedings of the IEEE Conference on Computer Vision and Pattern Recognition*, 2019, pp. 7683–7692.
  - [19] I. Alhashim and P. Wonka, “High quality monocular depth estimation via transfer learning,” *arXiv preprint arXiv:1812.11941*, 2018.
  - [20] J. H. Lee, M.-K. Han, D. W. Ko, and I. H. Suh, “From big to small: Multi-scale local planar guidance for monocular depth estimation,” *arXiv preprint arXiv:1907.10326*, 2019.

- 
- [21] Y. Wei, Y. Liu, C. Shen, and Y. Yan, “Enforcing geometric constraints of virtual normal for depth prediction,” *arXiv preprint arXiv:1907.12209*, 2019.
  - [22] Y. Chen, H. Zhao, and Z. Hu, “Attention-based context aggregation network for monocular depth estimation,” *arXiv preprint arXiv:1901.10137*, 2019.
  - [23] K. He, X. Zhang, S. Ren, and J. Sun, “Deep residual learning for image recognition,” in *Proceedings of the IEEE Conference on Computer Vision and Pattern Recognition (CVPR)*, 2016, pp. 770–778.
  - [24] M. Ramamonjisoa and V. Lepetit, “Sharpnet: Fast and accurate recovery of occluding contours in monocular depth estimation,” in *Proceedings of the IEEE International Conference on Computer Vision Workshops*, 2019.
  - [25] W. Chen, Z. Fu, D. Yang, and J. Deng, in *Advances in Neural Information Processing Systems (NIPS)*.
  - [26] B. Mildenhall, P. P. Srinivasan, M. Tancik, J. T. Barron, R. Ramamoorthi, and R. Ng, “Nerf: Representing scenes as neural radiance fields for view synthesis,” in *European Conference on Computer Vision (ECCV)*, 2020.
  - [27] V. Sze, Y.-H. Chen, T.-J. Yang, and J. S. Emer, “Efficient processing of deep neural networks: A tutorial and survey,” *Proceedings of the IEEE*, vol. 105, no. 12, 2017.
  - [28] A. G. Howard, M. Zhu, B. Chen, *et al.*, “Mobilenets: Efficient convolutional neural networks for mobile vision applications,” *CoRR*, vol. abs/1704.04861, 2017.
  - [29] M. Sandler, A. Howard, M. Zhu, A. Zhmoginov, and L.-C. Chen, “Mobilenetv2: Inverted residuals and linear bottlenecks,” in *Proceedings of the IEEE Conference on Computer Vision and Pattern Recognition (CVPR)*, 2018.
  - [30] X. Zhang, X. Zhou, M. Lin, and J. Sun, “Shufflenet: An extremely efficient convolutional neural network for mobile devices,” in *Proceedings of the IEEE Conference on Computer Vision and Pattern Recognition (CVPR)*, 2018.
  - [31] C. Zhang, P. Patras, and H. Haddadi, “Deep learning in mobile and wireless networking: A survey,” *IEEE Communications Surveys Tutorials*, vol. 21, no. 3, 2019.
  - [32] X. Tu, C. Xu, S. Liu, *et al.*, “Efficient monocular depth estimation for edge devices in internet of things,” *IEEE Transactions on Industrial Informatics*, vol. 17, no. 4, 2021.
  - [33] M. Tan and Q. Le, “EfficientNet: Rethinking model scaling for convolutional neural networks,” in *Proceedings of the International Conference on Machine Learning (ICML)*, vol. 97, 2019.
  - [34] J. Li, R. Klein, and A. Yao, “A two-streamed network for estimating fine-scaled depth maps from single rgb images,” in *IEEE International Conference on Computer Vision (ICCV)*, 2017.

- [35] S. F. Bhat, I. Alhashim, and P. Wonka, “Adabins: Depth estimation using adaptive bins,” in *International Conference on Computer Vision and Pattern Recognition (CVPR)*, 2021.



# Modelling and Characterisation of Metamaterials with Primitive and Advanced Cellular Structures

Nejc Novak<sup>1</sup>, Matej Vesenj<sup>1</sup>, Zoran Ren<sup>1</sup>

<sup>1</sup> Faculty of Mechanical Engineering, University of Maribor,  
Smetanova ul. 17, 2000 Maribor, Slovenia  
{n.novak, matej.vesenj, zoran.ren}@um.si

**Abstract.** *Modern metamaterials are among the most promising solutions for future applications in engineering, transportation, medicine, sports and many other fields of application. An overview of the development, design, fabrication, computational modelling and characterisation of metamaterials with primitive and advanced cellular structures are described and compared. The optimisation techniques based on validated computational models are developed to design spatially graded cellular metamaterials with enhanced mechanical properties.*

**Keywords.** Metamaterials, cellular structures, experimental testing, computational simulations, optimisation

## 1 Introduction

The rising cost of raw materials, lack of resources, and more stringent policies on sustainable development have resulted in an ever-increasing demand for lightweight and multifunctional materials with improved properties in engineering and other applications. One of the most promising materials for such applications are cellular materials, i.e. materials with internal cellular structure either on nano-, micro-, meso- or macro-scale. Cellular (meta)materials (engineered materials with designed properties) and structures are receiving increased attention in the engineering and scientific community over the past decade due to their low relative density and particular multifunctional properties, making them ideal for modern lightweight engineering and medical applications [1], [2]. Their mechanical and thermal properties make them very suitable for use in automotive, railway, naval, marine and aerospace industry, medicine, as well as in general, lightweight machine design as filters, heat exchangers, isolators, bearings, core material in sandwich structures and as fillers in hollow parts for additional stiffness/support, impact energy absorption and damping [3]. Rapid transition of cellular (meta)materials and structures for industrial applications is affected mainly by expensive fabrication, lack of relevant design guidelines, non-existent practical experience, and general distrust in using new materials. However, new advanced fabrication technologies, e.g. additive manufacturing, enable new trends in the lightweight modern design of cellular structures. This allows outperforming the existing technologies (melt/powder foaming using blowing agents, precursor/replication methods, placeholder method) to produce cellular structures, which do not allow for precise control of the shape, size, and distribution of cells with product predefined topology and morphology settings.

Since cellular structures are increasingly being used, it is critical for the engineering, material and commercial communities to recognise and develop their behaviour under various loading regimes to improve their performance by user-defined (individualised) design. Combining different base materials with the purposely designed internal cellular structure of different morphologies leads to a unique and outstanding combination of multi-material mechanical and thermal properties, tailored by careful design of the cellular structure. New advanced additive manufacturing techniques enable fabrication of the next generation of cellular metamaterials with complex internal cellular structure, adapted to a particular engineering application (including graded porosity) by computational simulations and topological optimisation techniques.

The mechanical behaviour of cellular (meta)materials and structures depends mainly on the relative density (porosity) and the base material, which can be metal or non-metal [1]. The other essential parameters of cellular structures defining their response are morphology (size and shape of the pores, open- or closed-cell structure), topology (regular or irregular pore distribution) and possible filler presence [4], [5]. With careful choice of the geometrical parameters and proper fabrication procedure of cellular structures, it is possible to achieve various mechanical (strength, stiffness, deformation behaviour), damping (phononic band gaps control) and thermal properties (thermal conductivity).

---

The detailed geometry of the fabricated structures and their influence on mechanical behaviour can be thoroughly evaluated using computed tomography (CT) scanning [6]. The previous research showed that advanced geometrical characterisation significantly depends on the quality of 3D data acquisition. Thus, new and more detailed data on the nano- and micro-scale are needed to build precise 3D digital twins. The 3D digital twins will offer the development of new cellular structures using advanced material engineering methodologies to define individualised geometry and mechanical response of the cellular structures.

In mechanical testing, the compression, tension and bending tests are well-reported and standardised in the literature. At the same time, there is still a lack of data in shear and dynamic testing. The dynamic and impact behaviour of cellular structures was widely studied in the last years using experimental and computational approaches [7]. However, not much work was done on the detailed deformation mechanism analysis of structures with functionally graded porosity [8]. Such a specifically designed internal cellular structure of metamaterials would provide the best desired mechanical response to particular loading conditions [9]. This response can, for example, result in constant deceleration of impacting projectile or constant reaction force on structures under the impact, which is very useful for different applications in safety and defence engineering and crashworthiness. A few successful dynamic experimental tests of auxetic cellular structures have been carried out so far [10], [11]. Simultaneously, computer simulations have been used to analyse the response of various cellular structures under dynamic loading, but only a few have been validated with the experiments [11].

The micro-architected cellular structures and micro- and nano- lattices with unit cell size below 1  $\mu\text{m}$  were developed recently [12], [13]. Periodic phononic metamaterials comparable to the wavelength of optical or acoustic waves were the first drivers towards the miniaturisation of cellular structures to control the band gaps. Recently, micro- and nano-lattices were also simultaneously designed to enable unique scale-independent properties such as tailorable stiffness, deformability, thermal expansion, and auxetic behaviour. The detailed analysis of mechanical behaviour at different strain rates, optimisation of the fabrication procedure and geometry, and the introduction of biodegradation and biocompatibility in micro- and nano-lattices is still very limited. The multiscale cellular structures are also a promising route toward developing life-lasting implants, stents and other medical devices [14].

As it can be concluded from the above short state-of-the-art review, there is still a lack of research in detailed geometry characterisation and the consequent development of digital twins, which will offer the development of new geometries and optimised fabrication procedures. The research on the mechanical testing and subsequent computational simulations of the multiscale multi-material lattices and the high strain rate and shear testing of cellular structures is also minimal. The work done at the University of Maribor on bridging the gap in the metamaterials research is presented.

## 2 Geometry and fabrication of (meta)materials

The (meta)materials are divided into groups in the following section depending on their topology and manufacturing procedure. Some of them are shown in Figure 1, where the development from primitive to advanced geometries through time is presented.

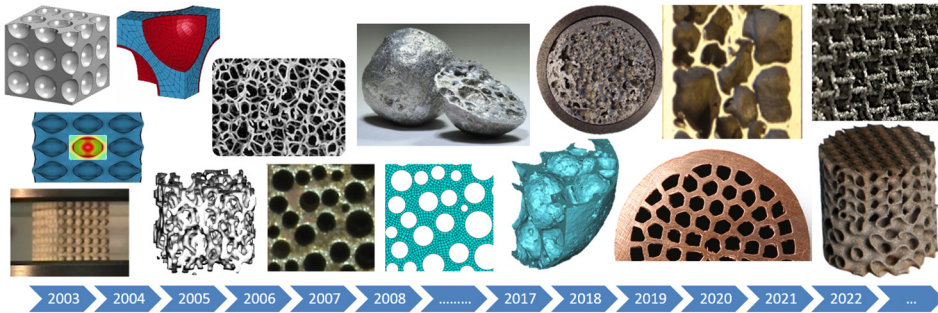

**Figure 1.** Research of cellular metamaterials at the University of Maribor in recent years: from primitive to advanced cellular geometry

### 2.1 Open-cell foams

Open-cell foam represents an interconnected structure of cells. Polymeric open-cell foam can be easily compressed and then naturally recover to its original shape. As a result, open-cell foam is most widely known for its use in the furniture industry as sofa cushion foam, foam mattresses, car seats and acoustic and soundproofing. The metal open-cell foams used are mainly produced using the investment casting method. The starting point is a porous polymer precursor. The pores are filled with a refractory slurry, dried and burnt. During combustion, the precursor pyrolysis, while the slurry hardens and forms the mould for the subsequent investment casting of the metallic matrix. The final step is removing the moulding material, which results in a porous metallic geometry very similar to the polymer precursor [5].

The mechanical properties of metal open-cell materials primarily depend on the properties of the base material, morphology and topology of the cells. The influence of the base material on the properties of metal foams is well studied. There are many empirically established relationships linking the properties of the base material and morphology with the properties of the cellular material. Metals and alloys used for metal foams must have a low density to maintain the advantage of low relative density over conventional solid materials. For this reason, the most commonly used metals for cellular materials are aluminium, magnesium, titanium and their alloys [15].

The influence of cell morphology on the mechanical properties of regular and irregular open-cell materials has been investigated by many authors using the representative unit cell. It was assumed that the behaviour of the cell material could be described well enough with a single, geometrically uniform cell. Since the cell geometry of fabricated open-cell foams differs from the geometric regularity, many authors have also investigated the cell morphology of

fabricated foams [16]. The mechanical behaviour of the open-cell foam can be further increased by introducing the polymer filler to the cellular structures [17]. The open-cell foams can also be used as a filler for foam-filled tubes [18].

## 2.2 Closed-cell foams

Closed-cell foam consists of interlocking micro- and macroscopic cells sealed shut, preventing air or water from passing through. This type of foam is stiffer and water-resistant, making it highly suited to shock absorption and thermal insulation. The closed-cell aluminium foam is produced using the powder metallurgical method [19], which consists of placing extruded, foamable precursor in a stainless steel mould in a preheated oven. The mould cavity is then filled by foaming the precursor, made of aluminium, silicon and titanium hydride. The mould with moulded foam is removed from the oven and cooled to room temperature. The aluminium foam is then removed from the mould made of carbon steel and cut lengthwise to prepare the specimens. The mechanical behaviour of closed-cell aluminium foams has been thoroughly characterised under free and laterally constrained compression loading conditions [20]. The same foams were also introduced into tubes (*ex-situ* foam-filled tubes), which enhanced the mechanical response. Powder metallurgical foam production also allows the production of closed-cell foams inside the tubes (*in-situ* foam-filled tubes) to achieve increased stiffness through better bonding between the foam filler and the outer tube [21].

## 2.3 UniPore structure

The unidirectional UniPore structure with longitudinal pores initially consists of an outer tube and thin-walled inner tubes, which are welded together with an explosion welding technique [22]. Before manufacture, the outer tube is tightly packed with inner tubes of a much smaller diameter over the entire length of the sample. The structure of the porous UniPore metal produced by this method has a uniform porous cross-section in the longitudinal direction, with the pore length being limited only by the size of the samples.

The inner tubes of different thicknesses with constant outer tube thickness were used to produce samples with three different porosities. The moderate welding condition necessary for the successful interface formation is not fulfilled in some regions between the inner pipes due to different collision angles of the pipes because of their round outer interface. This was also studied with computational simulations [23].

A new production method for UniPore structures was thus proposed [24]. It is based on rolling cheap thin metal foil with acrylic spacer bars positioned on a surface and subsequent explosive compaction. As soon as the thin film between the spacers is uniformly accelerated, the welding condition associated with the collision angle is considered stable, similar to conventional explosive welding. The manufacturing process of newly developed unidirectional metallic copper is similar to the one used for original UniPore cellular structures. Thin foils of other metallic materials can also be applied. It should be noted that the external

dimensions, the size of the pores, the thickness of the internal walls and the porosity can be easily adapted to individual application requirements.

## 2.4 Advanced pore morphology (APM) foam

Advanced pore morphology (APM) foam with a hybrid cellular structure was developed in Germany at the Fraunhofer IFAM, Bremen. APM foam elements consist of sphere-like interconnected closed-cell porous structures within solid outer skin. The manufacturing procedure consists of powder compaction and rolling of AlSi7 alloy with TiH<sub>2</sub> foaming agent to obtain expandable precursor material. The precursor material is cut into small volumes (granules), which are then expanded into spherical foam elements due to the heat reaction of the TiH<sub>2</sub> foaming agent in a continuous belt furnace. The internal structure of APM was evaluated [6], [25]. The APM elements were also used as a filler material for foam-filled tubes [26], [27].

## 2.5 Predesigned structures

Advanced fabrication techniques, such as additive manufacturing, allow producing predesigned structures. Three-dimensional auxetic cellular structures [28] presented here are built up from inverted tetrapods [11] and chiral auxetic structures [29]. The unit cells of inverted tetrapods are stacked in layers and then into the layered three-dimensional auxetic structure [30]. The auxetic cellular structures were constructed as CAD models and produced using the selective electron beam melting method (SEBM) from the Ti-6Al-4V alloy. The shape of the chiral auxetic structure unit cell corresponds to the 10th eigenmode of the regular cubic unit cell, which was presented in [31]. The mechanical properties can be further enhanced with the introduction of the polymeric filler [32].

High potential in many engineering applications also represents the periodic cellular materials, especially triply periodic minimal surfaces (TPMS). TPMS are complex 3-D topologies that locally minimise surface area for a given boundary and can be repeated periodically in three perpendicular directions [33]. These surfaces split the space into two or more interlocked domains, where each domain is a single connected and infinite component with no enfolded voids. Due to their novel topological features, TPMS have been employed in many engineering disciplines, such as tissue engineering [33], and structural engineering [34]. They also have optimal thermal and electrical conductivity [35] and optimised fluid permeability [35].

# 3 Design and characterisation

The main focus of the computational characterisation of the metamaterials is in the development of reliable numerical models, which have to be validated with the experimental tests. Different simplifications can be adopted to the computational models based on the geometry and planned further use.

### 3.1 Experimental testing

Most of the experimental tests were done in compression, which shows a typical mechanical behaviour with the initial elastic region, followed by the plateau and densification.

The behaviour of closed-cell foams under various loading conditions has been studied in detail [40] using micro-computer tomography ( $\mu$ CT) to track changes in the internal structure during the deformation of closed-cell aluminium foam [6]. Different closed-cell foams were tested under compressive and bending loading [41]–[45].

The compression [26] and bending [27] tests of APM and APM filled tubes were also performed. Besides this, the change in the geometry of the APM during loading was analysed in [46].

The influence of the loading velocity on the mechanical behaviour of closed-cell aluminium foams [47] was analysed with the Split Hopkinson Pressure Bar (SHPB) apparatus. The compression behaviour of foams made of aluminium alloys at high strain rates has also been investigated and discussed in [7], [48]. High strain rate testing using a powder gun was done for open-cell foams [49], closed-cell foams [50] and auxetic structures [11], [51]. Three-point bending tests were also used for the evaluation of the bending response of foam-filled tubes [27], [42], [43]. The shear testing of open-cell foams [52] and auxetic cellular structures [53] was also done recently.

### 3.2 Homogenised computational models

In the case of closed-cell foams, the simple computational model with the applied homogenised material model (crushable foam) with volumetric hardening was built in Abaqus finite element software, where the explicit solver was used for analysis. Due to the axial symmetry of the specimens, axisymmetric boundary conditions could be applied in the computational model. The crushable foam constitutive model parameters were determined with the optimisation algorithm, whereby first, the quasi-static (Q-S) experiment and the computational responses were compared (Figure 2). After optimising the material parameters, the same material model was used for the high strain rate (HSR) load. Good agreement can be observed for both quasi-static and HSR tests. The agreement between the experimental and computational responses is very good for both analysed strain rates (Figure 2). The discrepancy can only be observed at lower strains of the HSR response, where only the first stress peak could not be observed in the computational model due to the initial boundary conditions. The stress peak is a consequence of the collision in the experiments and represents a typical reaction of the structures during the initial phase of the impact but does not influence the global behaviour afterwards [11].

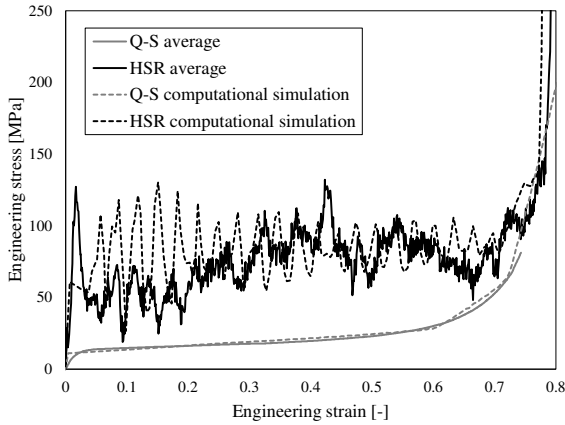

**Figure 2.** Engineering stress-strain relationship of closed cell foam under quasi-static (Q-S) and high strain rate (HSR) loading conditions.

The deformation behaviour under quasi-static and HSR loading conditions is shown in Fig 3. Under quasi-static load, a uniform deformation of the sample can be observed. The change in the deformation mode can be observed in the case of HSR loading, where the deformation is localised at the impact surface between the load plate and the specimen.

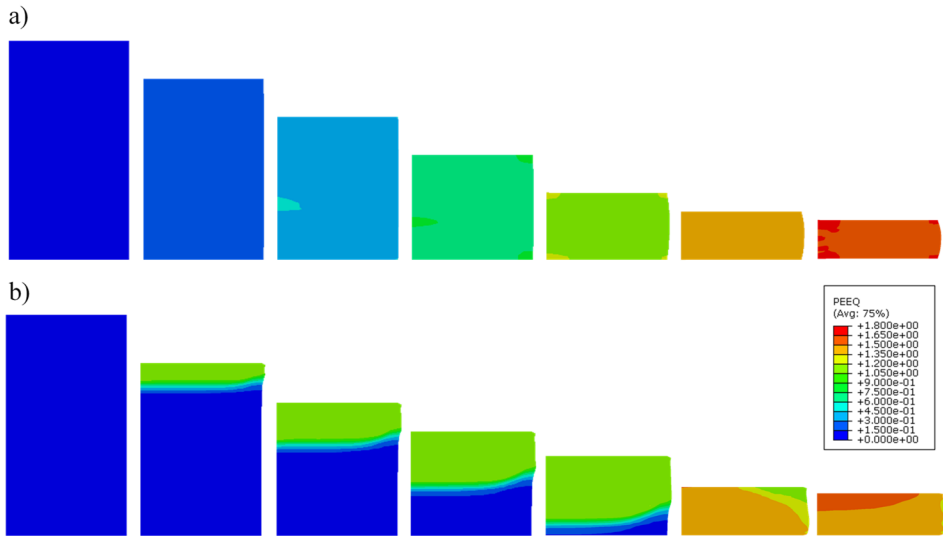

**Figure 3.** Evolution of the equivalent plastic strain (PEEQ) during the quasi-static (a) and high strain rate (b) deformation response of closed-cell foam modelled with homogenised computational model.



### 3.3 Discrete computational models

The discrete computational models offer a more precise analysis of the deformation behaviour of the metamaterials but at higher computational costs than the homogenised models. The strut based cellular structure, such as open-cell foams and auxetic structures, are mostly modelled with the beam finite elements [8], [36], [37].

The computational models of TPMS lattices are generated using the shell finite elements using the MSLattice code [38] to generate the fundamental lattice geometry of TPMS samples [40]. Meshing was performed by the PrePoMax software [45], and the boundary conditions were defined in the LS-PrePost software. The manufacturing imperfections resulting in plate thickness variation were also analysed [41] and were considered indirectly through the used material parameters determined by inverse parametric computational simulations.

The computational results of the constituent TPMS lattices were compared in terms of mechanical response (stress-strain relationships) and deformation behaviour to quasi-static experimental data from [39] for each analysed geometry and relative density. The computational models' deformation behaviour was validated with experimental observations recorded by HD video camera. The experimental and computational deformation behaviour of diamond TPMS lattices with different relative densities are shown in Figure 4. The overall response is quite comparable.

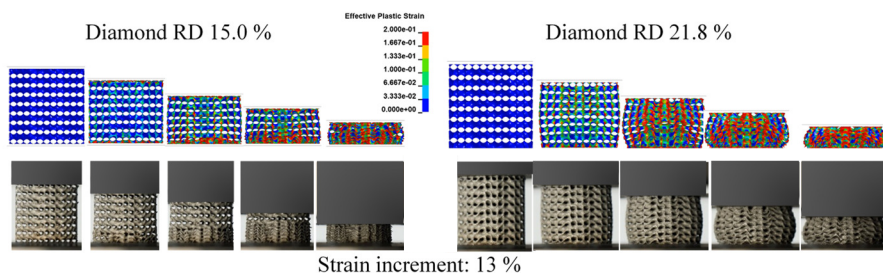

**Figure 4.** Comparison between the computational and experimental results in case of TPMS structures modelled with shell finite elements.

The volume finite elements were also used to discretise the open-cell foams. The correct geometric representation of fabricated aluminium open-cell foam samples requires a sufficiently high resolution of the  $\mu$ CT scan to capture geometric details and allow for accurate segmentation of the metallic phase. Figure 5 shows the deformation of the open-cell foam with contours representing von Mises stresses during loading. A gradual and uniform deformation of the foam is observed.

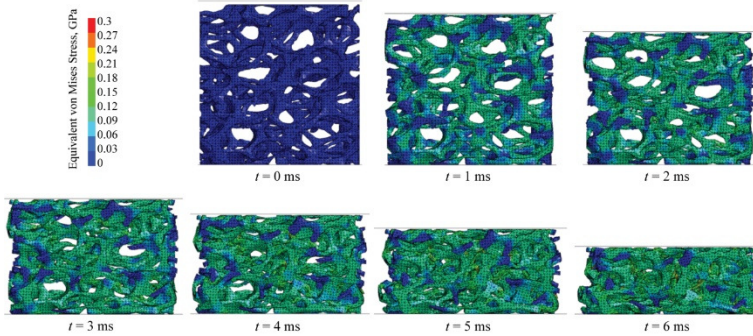

**Figure 5.** The deformation behaviour of open-cell foam modeled with volume finite elements.

## 4 Optimisation and development of new geometries

The validated computational models offer the possibility for further development and optimisation of new metamaterials.

New auxetic geometries were developed using a topology optimisation [54]. A 2D plane stress state simplification was used to model the auxetic structure. Only one cell of the periodic structure was selected as the domain for the multi-objective optimisation. One-quarter of this cell was used in the computational model to simplify the procedure further. In contrast, the rest of the cell was replaced by applying appropriate double symmetry boundary conditions. This simplification was introduced since double symmetry can be found in many existing auxetic structures such as re-entrant hexagons, symmetric chiral structures and sinusoidal ligament structures.

TPMS lattices are materials designed mathematically. Therefore, the advanced fabrication methods offer the fabrication of graded a hybrid structure, where different geometries can be combined. A graded or hybrid structure can enhance its topology to exhibit more advantageous and desired properties. A finite element computational model was developed in LS-DYNA to capture the mechanical properties of additively manufactured uniform TPMS-based lattices made of stainless steel 316L tested under quasi-static and dynamic loading conditions. The validated computational model was used to predict the mechanical behaviour of the newly developed hybrid TPMS cellular lattice with spatially varying gyroid and diamond cells in the longitudinal and radial direction (Figure 6). The new hybrid lattices were fabricated and mechanically tested, where good agreement between experimental and computational results was achieved [55].

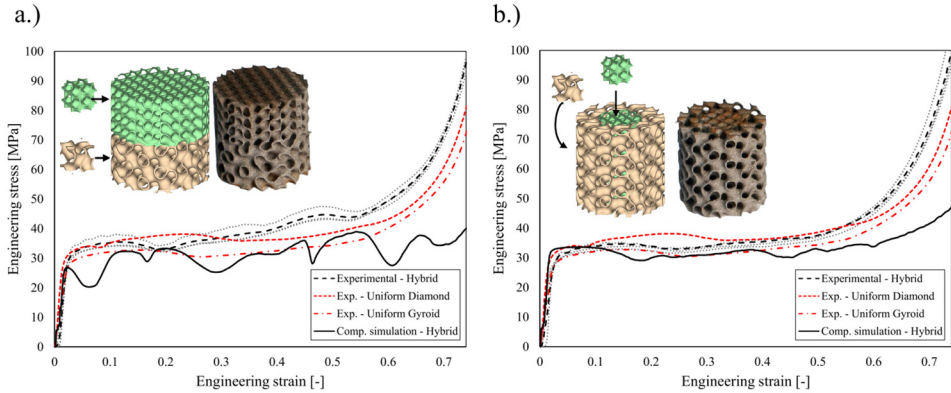

**Figure 6.** Comparison between the computational and experimental results for linear (a) and radial (b) hybrid TPMS lattices

Novel three-dimensional (3D) axisymmetric chiral structures with negative and zero Poisson's ratios were developed based on the existing 3D conventional chiral unit cell [37], [56]. The conventional tetra-chiral unit cell is mapped to the axisymmetric space to form the new 3D axisymmetric chiral structure. The structures are fabricated using additive manufacturing technology and experimentally tested under compression loading conditions. The computational model of axisymmetric chiral structures is developed and validated using the experimental data. The computational model was then used to evaluate the new axisymmetric chiral structures with graded cell structures. The newly developed axisymmetric chiral structures show enhanced mechanical properties compared to the existing 3D chiral structures.

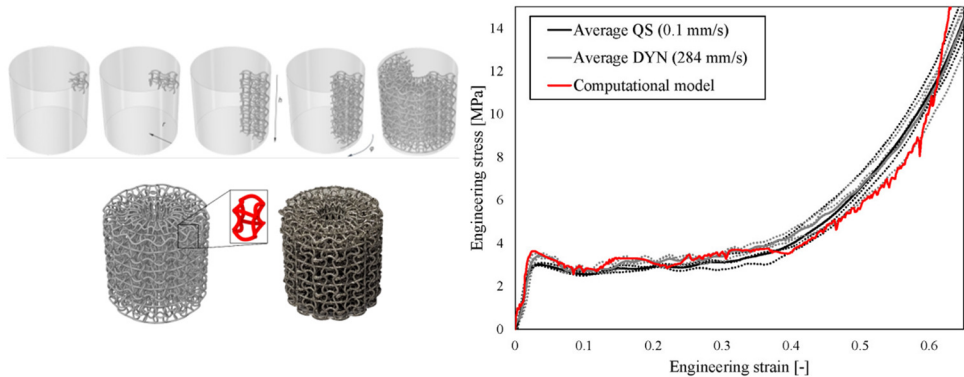

**Figure 7.** Design of the axisymmetric auxetic structure (left) and comparison between the computational and experimental results (right) under quasi-static (QS) and dynamic (DYN) loading conditions

## 5 Conclusions and outlook

The design, fabrication and mechanical behaviour of various cellular structures, from quasi-static to high strain rate loading, is presented. The experimental results of these structures under compression loading are compared to the specific energy absorption (SEA) capacity up to 50 % strain in Figure 8. The darker shading colours in Figure 8 correspond to lower specimen porosity in each analysed group of cellular structures, while lighted shading denotes higher porosity specimens. It can be observed that porosity and base material strongly influence the SEA capacity. Structures with lower porosity can absorb more mechanical energy through deformation than structures with higher porosity that exhibit lower stiffness. The same conclusions can also be reached for base materials, where materials with higher Young's modulus show higher SEA capacity. The best consistent SEA at 50 % strain can be observed for closed-cell foams, TPMS structures and UniPore structures. In UniPore structures, densification already appears at 50 % strain (Figure 8) and shows SEA is thus the total SEA for this type of structure. Closed-cell foams (Figure 8) and other analysed cellular structures densify at much higher strains, contributing to higher total SEA capacity.

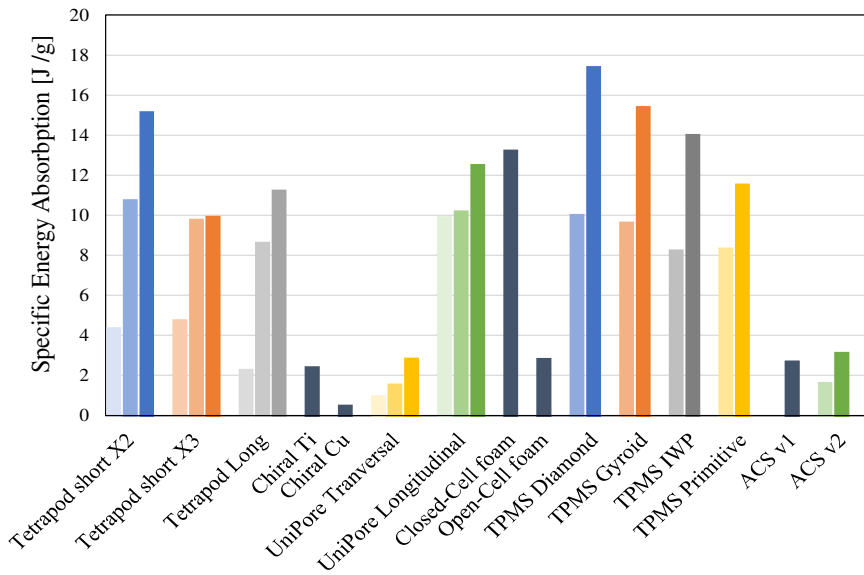

**Figure 8.** Comparison between the computational and experimental results

The computational simulations are an excellent tool for preliminary evaluation of new cellular designs and a better understanding of the deformation behaviour of various cellular structures. Different approaches are presented in this article, from simpler and fast homogenised computational models to advanced detailed and time-consuming processes, where a whole cellular structure is modelled with volume finite elements. A further improvement of computational models is imminent with the development of computational power and software capabilities, which will enable mesoscale modelling approaches to consider also

influences of fabrication defects. Consequently, it leads to more precise virtual prediction capabilities of cellular metamaterial deformation behaviour and better possibilities for optimisation of their mechanical response.

## Acknowledgements

The authors acknowledge the Slovenian Research Agency's financial support (postdoctoral research project No. Z2-2648 and national research programme funding No. P2-0063).

## References

- [1] L. J. Gibson and M. F. Ashby, *Cellular Solids: Structure and properties*. Cambridge, U.K.: Cambridge University Press, 1997.
- [2] J. Banhart, "Light-metal foams - History of innovation and technological challenges," *Advanced Engineering Materials*, vol. 15, no. 3, pp. 82–111, 2013.
- [3] M. Vesenjak, T. Fiedler, Z. Ren, and A. Öchsner, "Behaviour of syntactic and partial hollow sphere structures under dynamic loading," *Adv. Eng. Mater.*, vol. 10, no. 3, pp. 185–191, 2008.
- [4] M. F. Ashby, A. Evans, N. A. Fleck, L. J. Gibson, J. W. Hutchinson, and H. N. . G. Wadley, *Metal foams: a design guide*. Burlington, MA, Massachusetts: Elsevier Science, 2000.
- [5] D. Lehmhus, M. Vesenjak, S. de Schampheleire, and T. Fiedler, "From stochastic foam to designed structure: Balancing cost and performance of cellular metals," *Materials (Basel)*, vol. 10, no. 922, pp. 1–32, 2017.
- [6] M. Ulbin *et al.*, "Detailed Analysis of Closed-Cell Aluminum Alloy Foam Internal Structure Changes during Compressive Deformation," *Adv. Eng. Mater.*, vol. 20, no. 8, pp. 1–8, 2018.
- [7] Z. Zheng, J. Yu, C. Wang, S. Liao, and Y. Liu, "Dynamic crushing of cellular materials: A unified framework of plastic shock wave models," *Int. J. Impact Eng.*, vol. 53, pp. 29–43, 2013.
- [8] N. Novak, M. Vesenjak, and Z. Ren, "Computational Simulation and Optimisation of Functionally Graded Auxetic Structures Made From Inverted Tetrapods," *Phys. Status Solidi B*, vol. 254, no. 12, 2017.
- [9] N. Novak *et al.*, "Crushing Behavior of Graded Auxetic Structures Built from Inverted Tetrapods under Impact," *Phys. Status Solidi B*, vol. 256, no. 1, pp. 1–7, 2018.

- [10] T. Fíla *et al.*, "Impact Testing of Polymer-filled Auxetics Using Split Hopkinson Pressure Bar," *Adv. Eng. Mater.*, p. n/a--n/a, 2017.
- [11] N. Novak, K. Hokamoto, M. Vesenjak, and Z. Ren, "Mechanical behaviour of auxetic cellular structures built from inverted tetrapods at high strain rates," *Int. J. Impact Eng.*, vol. 122, no. August, pp. 83–90, 2018.
- [12] M. Mieszala *et al.*, "Micromechanics of Amorphous Metal/Polymer Hybrid Structures with 3D Cellular Architectures: Size Effects, Buckling Behavior, and Energy Absorption Capability," *Small*, vol. 13, no. 8, pp. 1–13, 2017.
- [13] O. Al-Ketan, R. Rezgui, R. Rowshan, H. Du, N. X. Fang, and R. K. Abu Al-Rub, "Microarchitected Stretching-Dominated Mechanical Metamaterials with Minimal Surface Topologies," *Adv. Eng. Mater.*, vol. 20, no. 9, p. 1800029, Sep. 2018.
- [14] H. M. A. Kolken, A. Fontecha Garciam, A. Du Plessis, C. Rans, M. J. Mirzaali, and A. A. Zadpoor, "Fatigue performance of auxetic meta-biomaterials," *Acta Biomater.*, 2021.
- [15] M. Borovinšek, M. Vesenjak, M. Jože, and Z. Ren, "Computational Reconstruction of Scanned Aluminum Foams for Virtual Testing," *J. Serbian Soc. Comput. Mech.*, vol. 2, no. 2, pp. 16–28, 2008.
- [16] M. Vesenjak, C. Veyhl, and T. Fiedler, "Analysis of anisotropy and strain rate sensitivity of open-cell metal foam," *Mater. Sci. Eng. A*, vol. 541, pp. 105–109, 2012.
- [17] I. Duarte, M. Vesenjak, L. Krstulović-Opara, and Z. Ren, "Crush performance of multifunctional hybrid foams based on an aluminium alloy open-cell foam skeleton," *Polym. Test.*, vol. 67, no. January, pp. 246–256, 2018.
- [18] I. Duarte, L. Krstulović-Opara, J. Dias-de-oliveira, and M. Vesenjak, "Axial crush performance of polymer-aluminium alloy hybrid foam filled tubes," *Thin-Walled Struct.*, vol. 138, no. January, pp. 124–136, 2019.
- [19] I. Duarte, M. Vesenjak, and M. Vide J., "Automated Continuous Production Line of Parts," *Metals (Basel)*, vol. 9, no. 531, pp. 1–13, 2019.
- [20] I. Duarte, M. Vesenjak, and L. Krstulović-Opara, "Compressive behaviour of unconstrained and constrained integral-skin closed-cell aluminium foam," *Compos. Struct.*, vol. 154, pp. 231–238, 2016.
- [21] I. Duarte, M. Vesenjak, L. Krstulović-Opara, and Z. Ren, "Static and dynamic axial crush performance of in-situ foam-filled tubes," *Compos. Struct.*, vol. 124, pp. 128–139, 2015.
- [22] K. Hokamoto, M. Vesenjak, and Z. Ren, "Fabrication of cylindrical unidirectional porous metal with explosive compaction," *Mater. Lett.*, vol. 137, pp. 323–327, 2014.

- 
- [23] M. Nishi, M. Oshita, M. Ulbin, M. Vesenjajk, Z. Ren, and K. Hokamoto, "Computational Analysis of the Explosive Compaction Fabrication Process of Cylindrical Uni-directional Porous Copper," *Met. Mater. Int.*, vol. 24, no. 5, pp. 1143–1148, 2018.
- [24] M. Vesenjajk, K. Hokamoto, S. Matsumoto, Y. Marumo, and Z. Ren, "Unidirectional porous metal fabricated by rolling of copper sheet and explosive compaction," *Mater. Lett.*, vol. 170, pp. 39–43, 2016.
- [25] M. Ulbin, M. Borovinšek, Y. Higa, K. Shimojima, M. Vesenjajk, and Z. Ren, "Internal structure characterisation of AlSi7 and AlSi10 advanced pore morphology (APM) foam elements," *Mater. Lett.*, vol. 136, pp. 416–419, 2014.
- [26] I. Duarte, M. Vesenjajk, L. Krstulović-Opara, and Z. Ren, "Compressive performance evaluation of APM (Advanced Pore Morphology) foam filled tubes," *Compos. Struct.*, vol. 134, pp. 409–420, 2015.
- [27] M. Vesenjajk, I. Duarte, J. Baumeister, H. Göhler, L. Krstulović-Opara, and Z. Ren, "Bending performance evaluation of aluminium alloy tubes filled with different cellular metal cores," *Compos. Struct.*, vol. 234, no. November 2019, p. 111748, Feb. 2020.
- [28] N. Novak, M. Vesenjajk, and Z. Ren, "Auxetic cellular materials - a Review," *Strojniški Vestn. - J. Mech. Eng.*, vol. 62, no. 9, pp. 485–493, 2016.
- [29] N. Novak, L. Starčević, M. Vesenjajk, and Z. Ren, "Blast response study of the sandwich composite panels with 3D chiral auxetic core," *Compos. Struct.*, vol. 210, no. November 2018, pp. 167–178, 2019.
- [30] J. Schwerdtfeger, P. Heinel, R. F. Singer, and C. Körner, "Auxetic cellular structures through selective electron beam melting," *Phys. Status Solidi B*, vol. 247, no. 2, pp. 269–272, 2010.
- [31] C. Körner and Y. Liebold-Ribeiro, "A systematic approach to identify cellular auxetic materials," *Smart Mater. Struct.*, vol. 24, p. 025013, 2014.
- [32] N. Novak, L. Krstulović, Z. Ren, and M. Vesenjajk, "Mechanical properties of hybrid metamaterial with auxetic chiral cellular structure and silicon filler," *Compos. Struct.*, vol. 234, 2020.
- [33] S. C. Kapfer, S. T. Hyde, K. Mecke, C. H. Arns, and G. E. Schröder-Turk, "Minimal surface scaffold designs for tissue engineering," *Biomaterials*, 2011.
- [34] O. Al-Ketan, R. Rowshan, and R. K. R. Abu Al-Rub, "Topology-mechanical property relationship of 3D printed strut, skeletal, and sheet based periodic metallic cellular materials," *Addit. Manuf.*, vol. 19, pp. 167–183, 2018.
- [35] S. Torquato and A. Donev, "Minimal surfaces and multifunctionality," *Proc. R. Soc. A Math. Phys. Eng. Sci.*, vol. 460, no. 2047, pp. 1849–1856, 2004.

- [36] N. Novak, M. Vesenjajk, L. Krstulović-Opara, and Z. Ren, "Mechanical characterisation of auxetic cellular structures built from inverted tetrapods," *Compos. Struct.*, vol. 196, no. January, pp. 96–107, 2018.
- [37] N. Novak, A. Mauko, M. Ulbin, L. Krstulović-Opara, Z. Ren, and M. Vesenjajk, "Development and characterisation of novel three-dimensional axisymmetric chiral auxetic structures," *J. Mater. Res. Technol.*, vol. 17, pp. 2701–2713, 2022.
- [38] O. Al-Ketan and R. K. Abu Al-Rub, "MSLattice: A free software for generating uniform and graded lattices based on triply periodic minimal surfaces," *Mater. Des. Process. Commun.*, vol. 3, no. 6, pp. 1–10, Dec. 2021.
- [39] N. Novak *et al.*, "Quasi-static and dynamic compressive behaviour of sheet TPMS cellular," *Compos. Struct.*, vol. 266, no. February, p. 113801, 2021.
- [40] L. Peroni, M. Avalle, and M. Peroni, "The mechanical behaviour of aluminium foam structures in different loading conditions," *Int. J. Impact Eng.*, vol. 35, no. 7, pp. 644–658, 2008.
- [41] I. Duarte, L. Krstulović-Opara, and M. Vesenjajk, "Characterisation of aluminium alloy tubes filled with aluminium alloy integral-skin foam under axial compressive loads," *Compos. Struct.*, vol. 121, pp. 154–162, 2015.
- [42] I. Duarte, M. Vesenjajk, and L. Krstulović-Opara, "Dynamic and quasi-static bending behaviour of thin-walled aluminium tubes filled with aluminium foam," *Compos. Struct.*, vol. 109, no. 1, pp. 48–56, 2014.
- [43] I. Duarte, M. Vesenjajk, L. Krstulović-Opara, I. Anžel, and J. M. F. F. Ferreira, "Manufacturing and bending behaviour of in situ foam-filled aluminium alloy tubes," *Mater. Des.*, vol. 66, no. PB, pp. 532–544, Feb. 2015.
- [44] M. Taherishargh, M. Vesenjajk, I. V. Belova, L. Krstulović-Opara, G. E. Murch, and T. Fiedler, "In situ manufacturing and mechanical properties of syntactic foam filled tubes," *Mater. Des.*, vol. 99, pp. 356–368, 2016.
- [45] I. Duarte, L. Krstulović-Opara, and M. Vesenjajk, "Axial crush behaviour of the aluminium alloy in-situ foam filled tubes with very low wall thickness," *Compos. Struct.*, vol. 192, no. January, pp. 184–192, 2018.
- [46] M. Borovinšek, M. Vesenjajk, Y. Higa, K. Shimojima, and Z. Ren, "Characterisation of geometrical changes of spherical Advanced Pore Morphology (APM) foam elements during compressive deformation," *Materials (Basel)*, vol. 12, no. 7, 2019.
- [47] M. A. Islam *et al.*, "Mechanical response and dynamic deformation mechanisms of closed-cell aluminium alloy foams under dynamic loading," *Int. J. Impact Eng.*, vol. 114, no. February 2017, pp. 111–122, 2018.
- [48] V. S. Deshpande and N. A. Fleck, "High strain rate compressive behaviour of aluminium alloy foams," *Int. J. Impact Eng.*, vol. 24, no. 3, pp. 277–298, 2000.



- 
- [49] S. Tanaka *et al.*, "High-velocity impact experiment of aluminum foam sample using powder gun," *Meas. J. Int. Meas. Confed.*, vol. 44, no. 10, pp. 2185–2189, 2011.
- [50] N. Novak *et al.*, "Compressive Behaviour of Closed-Cell Aluminium Foam at Different Strain Rates," *Materials (Basel)*., vol. 12, no. 24, p. 4108, 2019.
- [51] N. Novak, M. Vesenjajk, S. Tanaka, K. Hokamoto, and Z. Ren, "Compressive behaviour of chiral auxetic cellular structures at different strain rates," *Int. J. Impact Eng.*, vol. 141, no. February, p. 103566, Jul. 2020.
- [52] N. Novak, O. Duncan, T. Allen, A. Alderson, M. Vesenjajk, and Z. Ren, "Shear modulus of conventional and auxetic open-cell foam," *Mech. Mater.*, vol. 157, p. 103818, 2021.
- [53] N. Novak *et al.*, "Compression and shear behaviour of graded chiral auxetic structures," *Mech. Mater.*, vol. 148, no. June, 2020.
- [54] M. Borovinšek, N. Novak, M. Vesenjajk, Z. Ren, and M. Ulbin, "Designing 2D auxetic structures using multi-objective topology optimisation," *Mater. Sci. Eng. A*, vol. 795, no. May, p. 139914, 2020.
- [55] N. Novak *et al.*, "Development of novel hybrid TPMS cellular lattices and their mechanical characterisation," *J. Mater. Res. Technol.*, vol. 15, pp. 1318–1329, Aug. 2021.
- [56] M. Vesenjajk, N. Novak, and Z. Ren, "Axisymmetric chiral auxetic structure," EP21197296.3 patent pending, 2021.



# Supercritical fluids for the treatment of bioactive components

Milica Pantić<sup>1</sup>, Darija Čör Andrejč<sup>1</sup>, Maša Knez Marevci<sup>1</sup>, Zoran Novak<sup>1</sup>,  
Željko Knez<sup>1,2</sup>

<sup>1</sup> University of Maribor, Faculty for Chemistry and Chemical Engineering, Smetanova 17,  
2000 Maribor, Slovenia  
{milica.pantic1, darija.cor, masa.knez, zoran.novak}@um.si

<sup>2</sup> University of Maribor, Faculty of Medicine, Taborska 8, 2000 Maribor, Slovenia  
zeljko.knez@um.si

**Abstract.** *Supercritical fluids are marked as green solvents able to substitute toxic organic solvents. Therefore, processes involving supercritical fluids are seen as, besides others, green chemical processes with a huge potential for the food and pharmaceutical industry. Research on supercritical fluids evolved with time, spreading the possibilities and opportunities. The following paper gives a brief overview of the process involving supercritical fluids. Supercritical extraction, supercritical drying and impregnation of aerogels and particles from gas saturated solution are explained through the research performed and published by our research group. The most significant achievements are thoroughly explained and compared with the results available in the literature. The most important conclusions are underlined, and future remarks are discussed.*

**Keywords.** Supercritical fluids, supercritical extraction, aerogels, PGSS<sup>TM</sup>, supercritical impregnation

## 1 Introduction

The principles of green chemistry [1] and the principles of green engineering [2] raised concerns about environmental issues. They resulted in the development of "green chemical processes" that are safe and environmentally friendly. The possible solution for making chemical processes greener was to substitute hazardous solvents with aqueous solutions, supercritical fluids, ionic liquids, low-toxicity organic solvents. Therefore, the development of alternative technologies is essential. Reducing energy consumption, lowering toxic residues and byproducts, increasing conversion efficiency (reactants to products), and increasing final products' quality and safety are crucial requirements for future processes [3]. One of the ways to fulfill these demands is to apply high-pressure technologies.

Among high-pressure technologies, subcritical and supercritical fluids offer a high range of excellent technologies due to their physicochemical properties. The idea of supercritical fluids goes back to the 1820s, but an interest in them really began in the 1960s and 1970s, with research focused on extraction techniques. Later on, attention was drawn to the unique solvent properties of supercritical fluids. As presented by Fig. 1, three regions correspond to the pure compound's solid, liquid or gas states, separated by curves that meet at the triple point (TP). The vaporization/liquefaction curve has an end point called a critical point (CP), beyond which only one phase exists, the supercritical fluid (SCF).

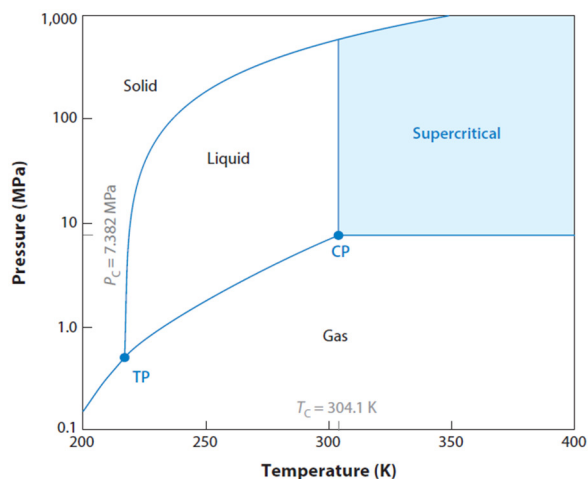

**Figure 1.** Phase diagram for the pure compound (CO<sub>2</sub>) [4]

Supercritical fluids have temperatures and pressures above their critical values ( $T > T_c$ ,  $p > p_c$ ). At a critical point, liquids and gases coexist, and supercritical fluids possess properties that are different from either liquids or gases under standard conditions. Their physical and chemical properties are between those of liquids and gases. Their main characteristics are densities similar to liquids, viscosities similar to gases, and diffusivities between those of gases and liquids, as shown in Table 1.

**Table 1.** Physical properties of gases, supercritical fluids and liquids [5].

Mobile Phase	Density (kg/m <sup>3</sup> )	Viscosity (kg/m/s)	Diffusivity (m <sup>2</sup> /s)
Gas	1	10 <sup>-5</sup>	10 <sup>-4</sup>
SCF	0.3*10 <sup>-3</sup>	10 <sup>-5</sup>	10 <sup>-7</sup>
Liquid	10 <sup>3</sup>	10 <sup>-3</sup>	5*10 <sup>-10</sup>

At the critical point, the diffusion coefficients are more than ten times higher than in liquids, making the mass transfer with supercritical fluids generally fast. Density is also highly sensitive to small changes in temperature and pressure. Even though the density values are similar to liquids, the solubilities can be much higher.

SCFs have the ability of liquids to dissolve materials and the ability of gases to penetrate porous solid materials. Furthermore, there are no surface tensions, thus no capillary forces during processing [6]. The solvent power of SCF is directly related to its density. By regulating the pressure, the solvent power can be manipulated to imitate the properties of organic solvents and eventually replace them. The separation of substances from solvents is easy to achieve.

Furthermore, it is possible to add modifiers to SCFs to change their polarities. For example, the nonpolar nature of scCO<sub>2</sub> can be overcome by adding modifiers in the form of polar organic co-solvents. This means that they have the potential to replace numerous chemicals in industries [6].

Table 2 gives insight into the most used sub and supercritical fluids and their critical values [7].

**Table 2.** Critical temperatures and pressures of the most used supercritical fluids

Supercritical fluid	T <sub>c</sub> (°C)	p <sub>c</sub> (bar)
Argon (Ar)	-122.5	48.6
Carbon dioxide (CO <sub>2</sub> )	31.1	73.8
Water (H <sub>2</sub> O)	374.0	220.6
Sulphur hexafluoride (SF <sub>6</sub> )	45.5	37.6
Xenon (Xe)	16.6	58.3
Fluoroform (CHF <sub>3</sub> )	25.9	48.2
Difluoromethane (CH <sub>2</sub> F <sub>2</sub> )	78.1	57.8
Dimethyl ether (C <sub>2</sub> H <sub>6</sub> O)	126.9	54.0
Propane (C <sub>3</sub> H <sub>8</sub> )	96.7	42.5

The most exploited supercritical fluid is carbon dioxide since it is chemically inert, nonflammable, nontoxic, recyclable, and naturally abundant. Additionally, the critical point of CO<sub>2</sub> occurs at mild temperature and pressure conditions of 31.1 °C and 73.8 bar. Therefore, it is a commonly used solvent in the food and pharmaceutical industries. Since it is a gas in ambient conditions, it can easily be removed from products by simply reducing pressure. Its critical temperature is close to the ambient, making it ideal for natural products thermolabile. It can be recovered for recycling and is miscible with organic solvents but can also replace them [8]. Carbon dioxide (O=C=O) is generally a nonpolar molecule, with the presence of a

small polarity, owing to a quadrupole moment, and, therefore, is categorized as a hydrophobic solvent. It dissolves lipids that are water-insoluble compounds, such as vegetable oil, butter, fats, hydrocarbons, etc. However, it does not dissolve hydrophilic compounds, such as sugar, proteins, salts, metals, etc. In industry, scCO<sub>2</sub> has mostly been used for coffee decaffeination, tea decaffeination, and the extraction of fatty acids from spent barley, pyrethrum, hops, spices, flavors, fragrances, and corn oil, as well as the extraction of color from red peppers. Some other applications include polymerization, polymer fractionation, particle formation for pharmaceutical and military use, textile dyeing, and the cleaning of machine and electronic parts [9].

The application of SCF is increased, especially in the field of chemical and biochemical reaction [10], for the synthesis of new materials and new catalyst support such as aerogels [11], for special separation techniques such as chromatography [12], extraction processes [13], and particle formation and product formulation [14].

SCFs are considered green solvents for the future due to their ecological benefits, particularly low energy consumption. Nowadays, they have been used in several processes operating on a large scale in the pharmaceutical, food, textile, and chemical industries [15].

## 2 Supercritical Extraction

Supercritical fluid extraction (SFE) is a separation process in which solids or liquids from the matrix are separated using SCF as the solvent. The specific properties of SCFs allow the solvent characteristic to be changed during the extraction process simply by changing the temperature and pressure. Investigation of SFE technology started a few decades ago. Hundreds of supercritical extraction plants operating at excessively high pressures (up to 2000 bar) have been designed worldwide. The most common high-pressure processes on a large industrial scale are the decaffeination of tea and coffee, the extraction of hop components, and the separation of lecithin from oil. Several industrial plants use different dense gases to isolate or fractionate various components. For example, the extracts obtained from the extraction of oils from seeds, fruits, leaves, and flowers, are further used in the food, pharmaceutical, and cosmetic industries [16, 17].

The use of supercritical fluids in extraction processes allows the production of environmentally friendly and safer extracts compared to conventional techniques. Using supercritical fluids in industrial extraction can replace much more harmful traditional solvents. One of the most important advantages of using SCFs as an extraction media is the possibility of selective extraction of components or fractionation of total extracts. One of the most important influencing factors is the mass transfer of the solute in the supercritical solvent, which depends on the solubility of the solute in each solvent. The mass transfer also significantly impacts the economics of the extraction process itself [18, 19].

Different compounds have different solubilities at different processing conditions. Temperature and pressure have the most significant influence on solubility in SCFs. For example, an increase in temperature at constant pressure decreases the density of the solvent.

As a consequence, the solubility of the solute decreases. Similarly, an increase in temperature at constant density increases the vapor pressure of the solute. Therefore, the substance is more soluble in the supercritical fluid. Depending on the system, one of the effects will prevail. The effect of pressure is more direct. A higher density of supercritical fluid will be achieved by increasing the pressure. Furthermore, the greater the density of the medium, the greater the solute's solubility [16].

The most common solvent used for supercritical extraction is  $\text{scCO}_2$ , especially for the extraction of nonpolar compounds. For the extraction of more polar components, a polar modifier or co-solvent is added to the  $\text{scCO}_2$ . Consequently, the solubility of the polar components in the supercritical solvent will increase. Examples of such modifiers are methanol, ethanol, etc. By adding a modifier, the density, and the viscosity increase. It results in a decrease in the mobile phase's diffusivity, thereby reducing the mass transfer [16].

For obtaining the highest possible yields, the process has to be optimized. Firstly, the influence of the process parameters on the extraction has to be investigated. One way to define the optimal process parameters is response surface methodology (RSM). This method uses a multiple regression model with the second-order polynomial equation from which the optimum parameters are chosen [20]. Extraction rates also depend on the morphology of the material and the location of the desired compounds in the plant material. Extraction rates will be high if desired compounds are located on the surface of a material. Conversely, if the desired components are located deeper inside the material, they will require more time to be extracted. Mass transfer depends on the particles' shape and size and the porosity of the solid material. If the material's structure is more complex and the desired compounds are deeper in the material, higher diffusion resistance is expected [21]. For this reason, sample preparation is crucial. The material needs to be mechanically pre-treated (grinding, milling, cutting, etc.) to reduce the average particle size. Smaller particles provide faster extraction due to smaller diffusion pathways and lower diffusion resistance. It is necessary to find a suitable particle size, as these particles should not be too fine despite mechanical processing.

## 2.1 Extraction of solids and liquids using supercritical fluids

Using SCFs as an extraction processing media enables processes at lower operating temperatures without organic solvents residuals and lower energy consumption. Final products are solvent-free. The basic scheme of the extraction procedure is shown in Fig. 2. The extractor is loaded with a certain amount of material. The gas is introduced from the solvent tank into the extractor by the high-pressure pump into the extractor at  $P_{\text{ext}}$  and  $T_{\text{ext}}$ . The material (extract) is collected at  $T_{\text{S1}}$  and  $P_{\text{S1}}$  in the separator.

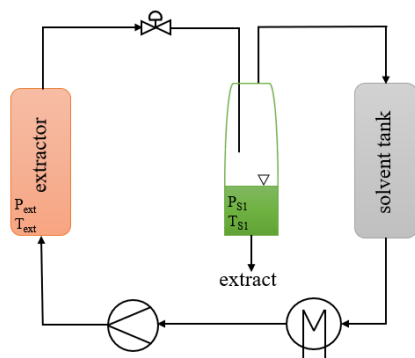

**Figure 2.** Basic flow sheet of SCF extraction apparatus [22]

Very important is selective extraction of components or fractionation of total extracts. This can be achieved by using different gases to isolate/fractionate the components and/or by changing the process parameters. The solubility of each component in the SCF is a fundamental input for the design of supercritical extraction processes for solid and liquid mixtures. The requirement for the extraction is the solubility of the components or mixtures of compounds in the SCF. In the extraction step solubility of the substance has to be at its highest level. While in the separation step, the solubility should be the lowest. That being the case, information on the phase equilibria of the systems is crucial for designing the operating pressures and temperatures of the SCF in the extraction unit. The theoretical mass of the SCF required to separate the compound from the solid or liquid mixture should be determined. The solute's solubility data in SCF mass transfer also has a major influence on the economy of the extraction process. Mass transfer models usually describe the extraction efficiency as a function of extraction time. For the design of extraction plants, it is preferable to present the efficiency as a function of the solvent to feed ratio (S/F). Typical extraction curves are shown in Fig. 3, describing the efficiency of chia seeds extraction as a function of S/F [23]. It is shown that pressure has a strong influence on the extraction yield. Higher operating pressures contributed to higher extraction yields at a constant temperature.

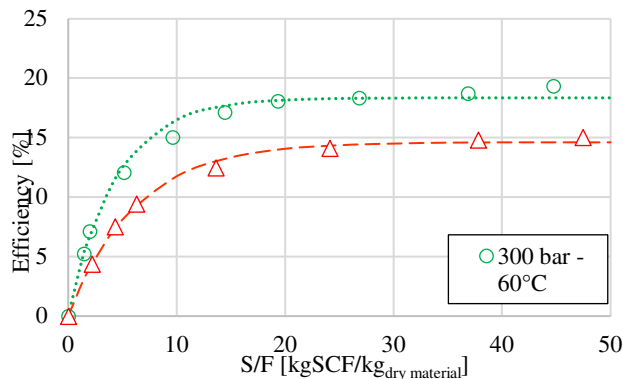

**Figure 3.** The extraction efficiency of chia seed extraction as a function solid to feed ratio



## 2.2 Published research

Our research group has performed multiple extractions with SCFs, published in scientific papers. Table 3 summarizes the natural materials, extracted compounds, fluid, and conditions used for the extraction processes. Most commonly, extraction of phenolic compounds was performed at different pressures and temperatures from various natural sources such as elderberry, pomegranate, oregano, etc. The most frequently used solvent was scCO<sub>2</sub>. The extraction of phenolic compounds from grape marc and elderberry has been investigated by Vatai et al. [24]. Extracts with high anthocyanin content, showing stability during storage, would be potentially interesting for commercial applications as natural colorants. Furthermore, saw palmetto berries, chia seeds, and sunflower seeds were extracted to obtain fatty acids by unconventional techniques [23, 25, 26].

Using water as a sub- or supercritical medium has become very interesting. Subcritical water is a good substitute for organic solvents and an environmentally friendly medium for treating various materials without adding a catalyst. Large amounts of residues are produced in the food industries. The treatment or extraction of natural waste matter with different SCFs for extracting more valuable active substances is attractive. For instance, Gagić et al. [27] extracted the chestnut bulk using subcritical water. The influence of process parameters, such as extraction time, temperature, and solvent-solid ratio on extraction yield was examined. Moreover, the yield of the main compounds, total phenol content, total tannin content, and antioxidant activity have been studied. Bark extract was highly rich in ellagic acid and with acceptable total phenols and total tannins levels. In a separate study, the separation of valuable compounds from cocoa shells by applying a sustainable green separation process of subcritical water extraction (SWE) was investigated. Used temperatures were in the range between 120 and 220°C. Different concentrations of theobromine, caffeine, theophylline, epicatechin, catechin, chlorogenic acid, and gallic acid were determined [28]. Phenolic compounds from large wood waste were extracted using SWE in the range of 100 to 300°C [29].

The industrial processing of tobacco generates a significant amount of waste. It consists of residues, pith, and dust. A majority is released directly into the environment and causing pollution. Therefore, the use of waste raw materials is preferable. Subcritical water, as an environmentally friendly and cheap technology, was used for the extraction of active compounds from different types of industrial tobacco waste. Valuable active compounds like nicotine, rutin, and phenolic acids (3,4-DHBA and chlorogenic acid) and other specific compounds, such as nicotinamide and nicotinic acid, were characterized [30].

**Table 3.** Published results from our research facility

Natural material	Extracted compound	Type of fluid*	Conditions	Ref**
Black yeasts	proteins	CO <sub>2</sub>	100, 300 bar, 35 ° C	[31]
Chamomile	matricine	CO <sub>2</sub>	100, 250 bar, 30, 40 ° C	[32]
Chestnut bark	ellagic and gallic acids, ellagitannins, sugars and sugar derivatives, furfural and levulinic acid	H <sub>2</sub> O	150, 250 ° C	[27]
Chia seed	fatty acids	n-propane	up to 300 bar, 40, 60 ° C	[23]
Chilli pepper	capsaicinoid	CO <sub>2</sub>	100-400 bar 40-80 ° C	[33]
Cocoa shell	theobromine, caffeine, theophylline, epicatechin, catechin, chlorogenic acid and gallic acid	H <sub>2</sub> O	120-220 ° C	[28]
Common juniper	terpenes	CO <sub>2</sub>	80-100 bar, 40 ° C	[34]
Curcuma longa L.	curcuminoids	H <sub>2</sub> O	100-200 ° C	[35]
Elder berry	phenolic compounds	CO <sub>2</sub>	150, 300 bar, 40 ° C	[24]
Feverfew flower	parthenolide	CO <sub>2</sub>	200-800 bar 40-80 ° C	[36]
Ganoderma lucidum	phenolic compounds	CO <sub>2</sub>	250, 300 bar 40, 50 ° C	[37]
Grape marc	phenolic compounds	CO <sub>2</sub>		
Green tea	caffeine, major catechins, flavonols	CO <sub>2</sub>	225-350 bar 50-80 ° C	[38]
Hop	$\alpha$ - and $\beta$ -acids	CO <sub>2</sub>	50-150 bar, 20-80 ° C	[39]
Horse chestnut	escins, esculin, fraxin, phenolics	H <sub>2</sub> O	100-250 ° C	[40]
Larch wood waste	phenolic compounds	H <sub>2</sub> O	100-300 ° C	[29]
Origano	phenolic compounds	CO <sub>2</sub>	150, 250 bar 40, 60 ° C	[41]
Pomegranate	phenolic compounds	H <sub>2</sub> O	100-220 ° C	[42]
Rosemary	carosic acid	CO <sub>2</sub>	100, 200 bar, 35, 60 ° C	[43]
Saw Palmetto berries	fatty acids and $\beta$ -sitosterol	CO <sub>2</sub>	300, 450 bar, 40, 60 ° C	[25]
Silybum marinum	vitamin E rich oil	CO <sub>2</sub>	100-300 bar 35-80 ° C	[44]
Sunflower seeds	fatty acids	H <sub>2</sub> O	60-160 ° C	[26]
Tagetes erecta	lutein	CO <sub>2</sub>	300 bar, 40-60 ° C	[45]
		n - propane	100-200 bar, 40, 60 ° C	

Natural material	Extracted compound	Type of fluid*	Conditions	Ref**
Tobacco waste	Nicotine phenolic compounds	CO <sub>2</sub> , H <sub>2</sub> O	100-300 bar, 40-80 ° C	[46]
Tobacco waste	nicotine, DHBA, chlorogenic acid, rutin	H <sub>2</sub> O	150-250 ° C	[30]

\*Type of sub/supercritical fluid, \*\*Reference

Few laboratory-scale studies are available for liquid – SCF extraction [47]. Several data on binary systems between liquid and SCF were found, but there is a lack of data for liquid/liquid/SCF systems. Extraction of liquid mixtures with supercritical fluids is similar to liquid-liquid extraction, except that compressed gas is used instead of an organic solvent. Pressure plays a vital role in the extraction of liquids with SCF. Selective extraction of the components or fractionation of the total extracts can also be carried out using different gases and by varying the parameters themselves. Also, in liquid-SCF extraction, one of the most important advantages of using SCF is the easy regeneration of the solvent. In conventional liquid-liquid extraction, solvent regeneration in most cases involves the necessary re-extraction or distillation, which is energy-intensive and therefore expensive. Another advantage is that liquid phase can be introduced into and continuously removed from the high-pressure unit.

To summarize, green extraction technologies such as supercritical fluid extraction can satisfy all current and likely future regulations relating to health, safety, and the environment. In addition to the most used carbon dioxide, other sub- or supercritical solvents are also used for sub- or supercritical extraction. The use of sub- and supercritical water has become particularly interesting. Currently, water is the cheapest solvent, and many substances are highly soluble in water. Industrial waste is a major problem in developed countries, with economic, environmental, and social impacts. For this reason, waste treatment has received a lot of attention in the last few years.

The main drawback of the SFE relates to high investments. The price of products obtained by SFE can be relatively high compared to those obtained by conventional methods. However, this disadvantage is balanced by the avoidance of legal costs, restrictions on solvents, and solvent residues in products used for animal or human utilization. In addition, there is the possibility of isolating and fractionating specific compounds from whole extracts. It is also possible to formulate them immediately and sterilize them without the use of high temperatures. All this promotes the use of dense gases for extraction purposes.

### 3 Aerogels: a method for impregnation of bioactive components

Nowadays, the term "aerogels" may refer to a wide range of different materials. At the beginning of their production in the 1930s [48], aerogels were materials obtained by applying supercritical drying technique, a novel and promising method in synthesizing dry without collapsing the solid network. Their main component is air, surrounded by a solid network. Back then, the interest in this field was low. In the 1980s, aerogels science was revived, leading to a huge interest in academic and industry research. As a result, the estimated market volume of silica aerogels was around 300-400 M euros in 2019 [49, 50]. Up to date, aerogels are recognized as materials having unique properties such as high specific surface areas, low densities, and high porosities. These properties lead to others, such as low thermal conductivity, low sound velocity, and high optical transparency. These properties are mainly obtained by applying the supercritical drying technique. However, the literature nowadays presents materials with all of the mentioned properties obtained without the supercritical drying technique [51]. This is why the definition and the term "aerogel" became controversial and prone to changes over time. In the more narrow context, aerogels are solid materials with open-celled, highly porous, and predominantly mesoporous structures (2-50 nm pores) derived from wet gels [52].

Most commonly, aerogels are prepared from molecular precursors through sol-gel processing. Firstly, sol is formed from the solution of precursors. Once the sol particles are condensed, gelation takes place, and gel is formed. A three-dimensional network of gel is usually filled with water or alcohol, forming hydrogels or alcogels. Obtaining dry gels from wet gels while maintaining the solid network may be challenging. At ambient pressure drying, the gel shrinks strongly during the evaporation of the solvent from the pores. The presence of liquid/gas interface in the pores during evaporation will cause the formation of capillary forces and pressure gradient on the pore walls. This leads to the collapse of the gel structure and the formation of the so-called xerogels [53]. The supercritical drying process overcomes the disadvantages of ambient pressure drying. If the solvent is put in a supercritical state, the presence of two phases is avoided. Both temperature and pressure are raised above the critical point of the corresponding solvent and kept there for a certain period of time. In a modified version mostly applied nowadays, the original solvent from the pores is exchanged with carbon dioxide (CO<sub>2</sub>) already in a supercritical state [54]. The use of CO<sub>2</sub> is convenient due to mild temperature and pressure conditions for the critical point. By simply reducing the pressure, it can be removed from the products since it is a gas at ambient conditions. It is convenient for thermolabile products due to low critical temperature. Lastly, supercritical CO<sub>2</sub> can sorb into many polymers causing their swelling and making them appropriate for the impregnation [54].

Aerogels are materials with various chemical and physical properties, leading to many applications [55]. To name just a few, they can be used in cosmetics [56], for diverse medical applications, especially as drug delivery systems [57], in microelectronics [58], as catalysts

[59], insulators [59], capacitors [60] or carriers for drugs in food and pharmaceutical industry [61].

Different types of aerogels are recognized in the literature: inorganic, inorganic-organic hybrid, and organic. Silica ( $\text{SiO}_2$ ) gels are the best-investigated materials in inorganic chemistry [50].  $\text{SiO}_2$  gels were used in the first attempt to produce  $\text{SiO}_2$  aerogels by Kistler. The production process of  $\text{SiO}_2$  aerogels was optimized over time and simplified. The network formation begins with the aqueous solution of salts or molecular precursors, usual alkoxysilanes in organic solvents. The prepared solution can be employed through sol-gel processing and, eventually, drying. In the case of non-silicate inorganic gels (titanium, zirconium, tin, aluminum), the network is formed by the same principles [50]. Organic molecules can be combined with the structural elements of inorganic materials. Organic molecules or groups are integrated during sol-gel synthesis. By modifying oxide aerogels with organic groups, the properties of aerogels can be improved. For example, the hydrophobicity and the elastic properties of  $\text{SiO}_2$  aerogels can be improved by incorporating organic groups [62, 63]. As an alternative to inorganic aerogels, purely organic resorcinol-formaldehyde aerogels were synthesized [64]. Despite the structural differences coming from different precursors, organic aerogels had common properties, such as high surface areas and high porosities.

Polysaccharide aerogels are among the best-investigated materials in the aerogels science community nowadays. Polysaccharides are natural materials with high stability, renewability, availability, and low toxicity [65]. Moreover, they are bioavailable, biodegradable, and prone to chemical modifications [66]. As such, polysaccharides are key ingredients for producing bio-based materials in life sciences (food, cosmetics, medical devices, and pharmaceuticals). The wide range of polysaccharides will allow incorporation into pharmaceutical products with different routes of delivery, target organs and/or drug release profiles. Furthermore, they can be applied as solid matrices in different forms, such as monoliths, beads, micro-, or nanoparticles [67].

### 3.1 Methods of impregnation

Due to their outstanding properties, aerogels are proposed as possible carriers for bioactive components. The impregnation process is convenient since aerogels are highly porous materials with high specific surface areas and open porous structures. The impregnation process is defined as imbuing or saturating a material or substance with something. Bioactive components, e.g., drugs, can be impregnated into aerogels following two different routes, as presented by Fig. 4. The first method implies the addition during the sol-gel process. It is a flexible and straightforward method in which the drug is added to the sol solution before gelation. However, it is essential to investigate if and how the added component may influence the gelation process. It must be able to withstand all the processing steps during the aerogel's synthesis. During supercritical drying, the added component may be washed out by  $\text{CO}_2$ . The second possibility is to impregnate bioactive components through the post-treatment of dried aerogels, e.g., supercritical impregnation, vapor deposition, reactive gas treatment. The

method implies the penetration of the drug into the aerogel's pores from the supercritical, liquid, or gaseous phase. The method is, however, limited by diffusion [50]. Supercritical impregnation of aerogels is a method mainly applied for poorly water-soluble components. The technique implies the incorporation of desired bioactive components, e.g., drugs, into aerogels under supercritical conditions. It is of the most promising methods of improving the dissolution and adsorption of poorly soluble drugs. Furthermore, supercritical impregnation has been proven to be more effective and tunable compared to the traditional sol-gel incorporation [68]. When it comes to poorly water-soluble drugs, the way to enhance their dissolution is by impregnating them into water-soluble carriers [69].

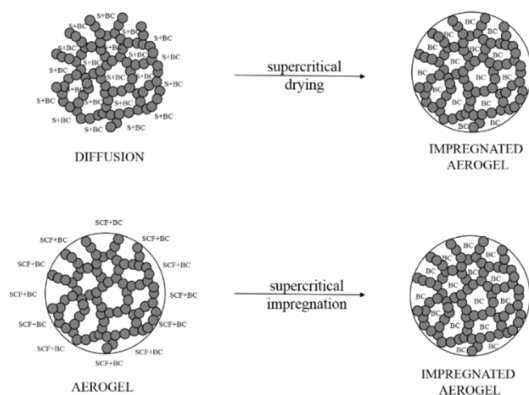

**Figure 4.** Impregnation processes of aerogels: diffusion via sol-gel versus supercritical impregnation process

### 3.2 Published results

Over the years, the research on aerogels in our laboratory evolved from silica-based to organic, polysaccharide-based aerogels. Table 4 summarizes the types of aerogels used, their shapes, impregnated bioactive components, methods for their impregnation as well as achieved loadings. The first progress was achieved with alginate aerogels, prepared as both beads and monoliths. The drug nicotinic acid was used as a bioactive component for the impregnation experiments. The drug was added via sol-gel synthesis and achieved loadings varied from 2.2 to 21% [70]. The drug dissolution profiles were improved by simply adding multi membranes to the core beads. Aerogels with more membranes resulted in higher loadings [23, 24]. The research was spread from alginate to pectin aerogels investigating the influence of ionic and non-ionic drugs on the drug release. Loadings as high as 37% were achieved for nicotinic acid and 33% for theophylline [24, 25]. In another attempt, both alginate, pectin, and their mixtures aerogels were used as carriers for diclofenac sodium achieving loadings as high as 80% depending on the used cross-linker for obtaining gels [74].

Since more than 40% of newly discovered drugs are hydrophobic [75], the focus shifted from soluble to poorly water-soluble drugs and finding ways to improve their bioavailability. Pectin aerogels were used as carriers for nifedipine, employing both techniques diffusion via sol-gel synthesis and supercritical impregnation [76]. Higher loadings were achieved in the

case of diffusion via sol-gel synthesis, namely 22%, compared to 13% in the case of supercritical impregnation. In separate research, the study on nifedipine was spread. Other polysaccharides, such as alginate, guar, and xanthan, were used as well. Diffusion via ethanol was used for the impregnation technique. Obtained loading varied between 21 to 37% [77]. Fat-soluble vitamins, cholecalciferol (vitamin D<sub>3</sub>), and menadione (vitamin K<sub>3</sub>) were supercritically impregnated into alginate aerogel beads as a way to improve their dissolution and bioavailability [78]. The highest achieved loadings for vitamin D<sub>3</sub> were 20 % and 16 % for vitamin K<sub>3</sub>. The dissolution of vitamin D<sub>3</sub> was significantly improved, reaching 20 times higher concentration than its crystalline form. Since vitamin D<sub>3</sub> showed high sensitivity to elevated temperatures, among others (oxygen, light), the subcritical impregnation technique was employed to preserve its stability and prevent degradation of the vitamin. The method implied the usage of subcritical CO<sub>2</sub> and temperatures below 31.1°C [79]. The temperatures from 5°C to 25°C were used, and loadings as high as 16% were obtained. The research focus shifted to producing coated aerogels.

The research focus shifted to the preparation of coatings. Firstly, xanthan-pectin coatings were prepared for orthopedic applications. Bioactive components, diclofenac sodium, and indomethacin were impregnated via sol-gel synthesis. Loadings as high as 4.5 and 4.2 % were achieved [80]. Furthermore, pectin aerogels coated with chitosan improved the dissolution and bioavailability of curcumin compared to its crystalline form. On the other side, coated pectin aerogels, unlike neat pectin aerogels, showed controlled curcumin release [81]. In the extended study, chitosan coatings were used for both pectin and alginate aerogels. The idea was to prepare neat polysaccharide aerogels (alginate, pectin, and chitosan) and compare them with coated pectin and alginate aerogels. The tested bioactive component was esomeprazole impregnated using both sol-gel synthesis and supercritical impregnation, and release profiles were optimized. Achieved loadings were similar, slightly higher in the case of sol-gel synthesis. The values varied from 4% to 22% for sol-gel synthesis and 2% to 17% for supercritical impregnation [82].

It is essential to distinguish between these two techniques. As practice showed that higher loading could be achieved using impregnation via diffusion through sol-gel synthesis (either water for soluble or ethanol for poorly water-soluble), the quantity of used bioactive components is huge (depending on their solubility). On the contrary, a much lower quantity of bioactive components is required using supercritical fluids and supercritical impregnation. At the same time, the loadings achieved are comparable to those obtained by sol-gel synthesis.

As mentioned, extensive research work has been done over the years.

The primary focus was on silica aerogels. Silica aerogels possess extremely high porosities (up to 99.8%), high inner surface areas (100-1600 m<sup>2</sup>/g), and low densities (0.003-0.5 g/cm<sup>3</sup>) [49]. Due to these outstanding properties, they have been proposed for biomedical applications. Silica aerogels with different modifications, hydrophilic, hydrophobic, amino-functionalized silica, etc., were used as carriers for different bioactive components [83]. The impregnation process and final loading showed to be dependent on the type of the drug, the solubility of the drug, type and characteristics of aerogel, impregnation conditions, etc. [83]. One of the most important revelations was that above a certain concentration, a solute of

bioactive component crystallizes, causing the collapse of the aerogel's structure. Using concentrations below the saturation concentrations is crucial to obtain amorphous products. The amorphous form of drugs is a highly desirable product, stable over a more extended period [84–87]. When it comes to supercritical impregnation of aerogels, it was discovered that the density of CO<sub>2</sub> under certain conditions is high, so the adsorption of CO<sub>2</sub> molecules takes place along with the bioactive components. After the depressurization, CO<sub>2</sub> molecules desorb, and only the traces of CO<sub>2</sub> stay in the aerogels at ambient pressures [88]. Ketoprofen and ibuprofen are the best investigated bioactive components for impregnation into aerogels. Loading as high as 16–30% [89–91] in the case of ketoprofen and 24–29% [88, 92] in the case of ibuprofen were achieved.

In the last decade, the world has been moving towards natural materials over synthetic materials. Many natural materials and polysaccharides among them are gaining increasing attention. Polysaccharide-based aerogels, like silica aerogels, are highly porous (up to 99%), lightweight (0.07–0.46 g/cm<sup>3</sup>) with high inner surface areas (70–680 m<sup>2</sup>/g). They proved to enhance drug bioavailability and drug loading capacity [67]. Besides polysaccharides, other organic materials such as proteins have also been proposed for the preparation of natural organic aerogels. Aerogels based on natural proteins are a new opportunity for life science and food applications due to their biocompatibility and biodegradability [93, 94]. Using natural organic aerogels, loadings for ketoprofen varied from 9 to 22% and for ibuprofen from 20–30%. Ketoprofen and ibuprofen loading showed to be dependent on the type of the polysaccharide or protein used. Alginate, alginate/pectin, alginate/ $\kappa$ -carrageenan, corn starch, starch, pectin, whey protein were used for the impregnation of ketoprofen [67, 91, 94–96], while alginate, starch, and silk fibroin protein were used for the impregnation of ibuprofen [92, 93, 97].

Besides mentioned bioactive components, many others have been used. To name just a few, active components such as miconazole, flurbiprofen, griseofulvin, dithranol [98], terfenadine, niclosamide [89], domperidone [99], artemisinin, rifabutin, loratadine, dihydroquercetin [92],  $\alpha$ -tocopherol [100] have been used for the impregnation into a variety of aerogels.

As presented, aerogels are an inexhaustible source for impregnation for many bioactive components. Throughout extensive research, aerogels proved to be extraordinary carriers for bioactive components for a variety of biomedical applications. In the area where the concern for environmental issues is on its maximal level, we are able to produce products using green energy, green processes, and completely natural materials. Even though aerogels haven't yet found their way into the pharmaceutical and food industry, they must not be excluded or underestimated. They have a remarkable potential to grow, develop and stand out.



**Table 4.** Published results from our research facility

Type	Bioactive component	Method	Loading, %	Reference
Alginate, beads	Nicotinic acid	Sol-gel synthesis	11.6-21	[70]
Alginate, monoliths			2.2-4.1	
Alginate, multi membrane beads	Nicotinic acid	Sol-gel synthesis	6.4-179.3*	[71]
Alginate, multi membrane beads	Nicotinic acid Theophylline	Sol-gel synthesis	53.5-179.3* 35.1-644.8	[72]
Pectin, multi membrane beads	Nicotinic acid Theophylline	Sol-gel synthesis	25-37 21-33	[73]
Alginate beads	Diclofenac sodium	Sol-gel synthesis	40.5-79.6	[74]
Pectin beads			44.2-79.0	
Alginate-pectin beads			35.9-56.9	
Pectin, tablets	Nifedipine	Sol-gel synthesis Supercritical impregnation	22 13	[76]
Guar, tablets	Nifedipine	Sol-gel synthesis	25.7	[77]
Pectin, tablets			37.4	
Xanthan, tablets			34.9	
Alginate, tablets			21.7	
Alginate beads	Vitamin D <sub>3</sub> Vitamin K <sub>3</sub>	Supercritical impregnation	5.2-20.1 6.1-16.0	[78]
Alginate beads	Vitamin D <sub>3</sub>	Supercritical impregnation Subcritical impregnation	9-20 2-16	[79]
Xanthan-pectin coatings	Diclofenac sodium Indomethacin	Sol-gel synthesis	4.5 4.2	[80]
Pectin, tablets	Curcumin	Sol-gel synthesis	**	[81]
Pectin coated chitosan, tablets				
Pectin, tablets	Esomeprazole		19.5 ± 2.0	[82]
Alginate, tablets		Sol-gel synthesis	11.5 ± 0.5	
Chitosan, tablets			22 ± 1.5	
Pectin coated chitosan, tablets			4 ± 0.5	
Alginate coated chitosan, tablets			8.5 ± 0.5	
Pectin, tablets	Esomeprazole	Supercritical impregnation	16.5 ± 1.0 10 ± 0.5	[82]
Alginate, tablets			15.5 ± 1.5	
Chitosan, tablets			2.5 ± 0.5	
Pectin coated chitosan, tablets				
Alginate coated chitosan, tablets			9 ± 0.5	

\* not standardized method, \*\* not reported

## 4 Particles from gas saturated solutions (PGSS™)

In PGSS™ process, compressible media is solubilized in the substance or mixture of substances that should be micronized [101]. Several substances which are practically insoluble in sub-critical or supercritical fluids dissolve a considerable mass of gasses in the liquid phase. For several solid substances in the presence of gas, the melting point decreases with increasing gas pressure due to the solubilization of gas in the solid. After solubilizing SCF into emulsion suspended liquid or molten material, SCF containing liquid is rapidly expanded (through a heated nozzle) into a pressurized vessel leading to precipitation and formation of fine particles [102]. Gas saturated solution in an expansion with the compressible media is evaporated, and due to the Joule-Thomson effect, the solution is cooled below the melting point [103].

Equipment required for the process includes a compressed scCO<sub>2</sub> cylinder, two high-pressure liquid pumps for scCO<sub>2</sub> and the other solvents, high-pressure chambers, product separation units, liquefying units, recirculating pumps, manometers, in-line filters, thermocouples, and a host of others. Parameters that need to be optimized for each application include temperature, pressure, and feed emulsion rate. Technically for the batch-wise operated plant presented in Fig. 5, the substance to be micronized is filled in an autoclave, later, the gas is loaded and the system is equilibrated. Gas is solubilized in the substances or mixture of substances. The gas saturated system is expanded via a nozzle [104]. In a continuously operated plant, the substance to be powdered (molten or liquid, emulsion or suspension) is fed to a static mixer, mixed with sub-critical or supercritical fluid. After mixing, the multicomponent system is expanded via a nozzle. Produced particles of micron size are easily separated from gas streams in a spray tower cyclone. The PGSS™ process could be used to produce particles of pure substances, but the main advantage of the process is the production of composites of miscible or even immiscible substances. Frozen emulsions or liquid-filled particles could be produced [105]. As mentioned before, the PGSS™ process could operate batch-wise or continuously, and today several plants from the lab up to industrial-scale are in use in different industries [106].

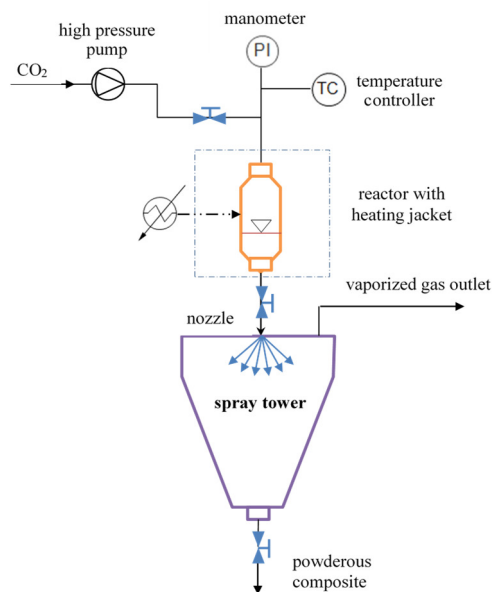

**Figure 5.** Scheme of a batch PGSS<sup>TM</sup> process [107]

The technique known as supercritical melt micronization (scMM) is more efficient in atomizing and drying at low temperatures when compared with spray drying [108]. It has found application in powdering food and food-derived products like soy lecithin, chocolate, cocoa butter, citric acid,  $\beta$ -carotene, menthol, ricinus fat, shea butter, phytosterols, mono, and diglycerides [109]. Edible water in oil emulsion wrapper product has been prepared using supercritical melt micronization. Prepared products had a firm texture and were temperature stable. Smaller water droplet size emulsions were produced, leading to an increase in microbiological stability. Wrapper products have applications mainly in baking, frying, and cooking without leaving any sticky/waxy mouthfeel. Milk fat micronized by PGSS<sup>TM</sup> proved stable  $\beta'$  polymorphism. As milk fat is temperature-sensitive, this technique was well suited, and the properties of powder formed were well preserved during storage. Lavandin essential oil was micronized using PGSS drying [110]. Several carriers and pharmaceutical substances have also been micronized using a PGSS<sup>TM</sup> process [111, 112].

PGSS<sup>TM</sup> process was applied for powder formation of monostearate and tristearate. It allowed the formation of particles below 50  $\mu\text{m}$  from substances that are non-soluble in supercritical fluid but absorb a large amount of gas that either swells the substance or decrease its melting point. Micronized samples had narrow particle-size distributions and improved properties compared to the conventionally produced powders [113]. The influence of process parameters like pre-expansion pressure and pre-expansion temperature on the degree of crystallinity, crystal form, particle size, particle-size distribution, and morphology of micronized monostearate and tristearate was investigated. Micronization was performed in a pressure range from 60 to 210 bar and at two different temperatures. The degree of crystallinity and crystal form of micronized samples were determined after micronization and

after three months of storage under controlled conditions. The average sizes of obtained particles from starting tristearate of approximately 4  $\mu\text{m}$ , and monostearate of approximately 150  $\mu\text{m}$ , were reduced to 10–40  $\mu\text{m}$  depending on pre-expansion pressure and temperature. Agglomeration of samples during storage occurred. The polymorphic form remained the same after micronization, but the degree of crystallinity for both substances was lower compared to the samples before micronization. The samples during storage were re-crystallized. Re-crystallization process for monostearate was almost the same for all pressures and temperatures. The results for tristearate showed faster re-crystallization for pressures higher than 115 bar at a higher temperature. During storage, polymorphic form remained the same for monostearate ( $\beta$  form), and in the case of tristearate, the slow transformation from  $\beta'$  to  $\beta$  form occurred. SEM analysis indicated particles with irregular and porous shapes after micronization, where the surface changed with storage in both cases.

PGSS<sup>TM</sup> is a favorable technique for polymeric encapsulation of drugs, proteins, and peptides as fine particles without employing organic solvents. In this process, carriers such as polymers are melted with the dissolved or suspended bioactive components contained within them. Ibuprofen has been successfully micronized with different carrier materials such as polyethylene glycol (PEG) 6000 [114], poloxamers, Gelucire1, and glyceryl monostearate [115]. PEG 4000 has also been used as a carrier for the micronization of poorly water-soluble drugs [116]. Sievers *et al.* [117] described a process to obtain fine particles usable in a dry powder inhaler form. The procedure consists of the production of a dense, fine droplet aerosol plume followed by a drying step. This patented process has been performed with lactose for developing a dry powder inhaler of anti-asthmatic drugs: albuterol sulfate and cromolyn sodium. The fine spherical particles in the range of 0.1– 3  $\mu\text{m}$  made the product suitable for inhalation. The particle size of nifedipine was reduced from 50 to 15  $\mu\text{m}$  in a pre-expansion pressure range from 100–200 bar. The influence of pressure on particle size has been evaluated. At higher pressures, smaller particles were formed [118]. Fenofibrate lipid-based solid dispersion formulation containing fenofibrate and Gelucire1 50/13 has been described by Pestieau *et al.* [119].

Fenofibrate solid dispersions were also investigated by Krananja *et al.* [107]. PGSS<sup>TM</sup> process was applied to the carrier materials Brij S100 and polyethylene glycol PEG 4000 to incorporate the insoluble drugs nimodipine, fenofibrate, and o-vanillin to improve their bioavailability and dissolution rate. With increasing pre-expansion pressure, the mean particle size of nimodipine/Brij S100, vanillin/Brij S100, and vanillin/PEG 4000 decreased. In a mixture of fenofibrate/Brij S100, anticipated effective surface areas were probably slightly reduced with pressure due to agglomeration and resulted in increased mean particle size of precipitated particles. The influence of drug/carrier ratio on particle size distribution was investigated in a nimodipine/Brij S100 system. The mean particle size at pressures higher than 150 bar increased with increasing drug/carrier ratio. For example, at a pressure of 200 bar, the mean particle size decreased from 61.28  $\mu\text{m}$  at 0.10 drug/carrier ratio and up to 47.92  $\mu\text{m}$  at 0.20 drug/carrier ratio. The effect of temperature was investigated in the o-vanillin/PEG 4000 system. After the temperature increased from 45°C to 60°C at 150 bar, particle size increased from 41.45 to 59.5  $\mu\text{m}$ .

The research has also been performed for the formulation of the anthocyanin-based extracts and concentrates into powder form by using different supercritical micronization processes and different carriers to provide higher stability of the product during storage. Using the PGSS<sup>TM</sup> method, encapsulation of different anthocyanin-based extracts and concentrates with palm fat as carrier material was tested. Different types of anthocyanin concentrate, their concentrations, as well as different mass ratios of the carrier and the liquid to be encapsulated, were investigated. Anthocyanins, used in research, were extracted from grape marc or elderberry. The batch micronization experiments were carried out at pre-expansion temperatures of 70 °C and in the pressure range between 120 and 150 bar. The melted palm fat was mixed with emulsifier and with anthocyanin-concentrate using an electrical homogenizer. The formulated products were analyzed for their color properties. In the study, homogeneous, free-flowing anthocyanin-based powders were obtained. According to the different types of extract and the different concentrations of the extract in the solution, the visually observed color of the products varied from light pink to darker red-brownish. The average particle size of the obtained products varied from 8 to 18 µm, and the particle size distribution was relatively narrow. With increasing the liquid content on the carrier, the particle size of the powders decreased. Particles were very porous and mostly amorphous [120]. The obtained powderous anthocyanin-palm fat products showed good color stability, which gives suitable bases for potential applications in the future. Table 5 presents the examples of compounds and carriers formulated by PGSS<sup>TM</sup>.

**Table 5.** Published results

Bioactive component	Carrier	Conditions	Reference
Monostearate Tristearate	without carrier	115-215 bar, 54, 60, 70 ° C	[113]
Green tee extracts	without carrier	73-100 bar, 33-79 ° C	[121]
Mixtures of ceramide 3A and cholesterol	without carrier	60-210 bar, 60, 70, 80 ° C	[122]
Nimodipine Fenofibrate O-vanillin	Brij S100 PEG 4000	100-250 bar, 45, 60 ° C	[107]
Banana puree Strawberry puree Blueberry concentrate	Maltodextrin	112-152 ° C	[123]
Curcuminoids	PEG 1500	160 bar, 50 ° C	[124]
Anthocyanin concentrates from grape residues	Palm fat	100 bar, 60 ° C	[120]

## 5 Conclusion

Technologies based on supercritical fluids offer various advantages over technologies based on organic solvents. The significant benefits are the thermophysical properties of SCFs, which can be easily tuned by adjusting the operating pressures and temperatures. Subcritical and supercritical CO<sub>2</sub> and subcritical water are solvents with great potential for extraction processes. They are non-carcinogenic, nontoxic, not mutagenic, nonflammable, and thermodynamically stable. CO<sub>2</sub> allows operations at low temperatures, while water is the cheapest available solvent. The demand for new products with special characteristics, high purity, and lower energy consumption for applications in different fields are increasing. With the use of SCFs, such products can be produced.

The processing of natural products with new technologies has been an extensive area of research in the past few decades. The main advantages of using SCFs are solvent-free products, no co-products, and already mentioned low processing temperatures. In addition, selective extraction of components or fractionation of total extract is a huge advantage. The possible limitations could be the prices of prepared products, which are relatively high compared to conventionally prepared.

The main advantage of using sub or SCFs to produce fine particles is the tunability of solvent properties. Micronisation processes can be easily connected to supercritical extraction process processes. On the other side, the impregnation of bioactive components (extracts as well) using aerogels can increase the bioavailability of poorly soluble drugs, improve their stability and release kinetics. A large number of research articles concerning aerogels in drug delivery application is proof of the aerogel's great potential.

## Acknowledgments

Special thanks are given to the Slovenian Research Agency (ARRS) for financial support of research program P2-0046: Separation processes and product design and research projects; J2-1725: Smart materials for bio-applications and L2-3175: Advanced Extraction and Formulation of Functional Tannin Food Supplements with Beneficial Health Effects.

## References

- [1] P.T. Anastas and J.C. Warner, "Green Chemistry: Theory and Practice," *Oxford University Press*, 2000.
- [2] P.T. Anastas and J.B. Zimmerman, "Design through the 12 principles of green engineering," *Environmental Science & Technology*, vol. 37, no. 5, pp. 94A-101A, 2003.

- 
- [3] F. Cansell, C. Aymonier, and A. Loppinet-Serani, "Review on materials science and supercritical fluids," *Current Opinion in Solid State & Materials Science*, vol. 7, no. 4, pp. 331–340, 2003.
- [4] Ž. Knez, M. Knez Hrnčič, and M. Škerget, "Particle Formation and Product Formulation Using Supercritical Fluids," *Annual Review of Chemical and Biomolecular Engineering*, vol. 6, no. 1, pp. 379–407, 2015.
- [5] E. Kiran, P.G. Debenedetti, and C.J. Peters, "Supercritical fluids: fundamentals and applications." *Springer Science & Business Media*, vol. 366, 2012.
- [6] V. Goodship and E.O. Ogur, "Polymer Processing with Supercritical Fluids," *iSmithers Rapra Publishing*, vol.15, 2004.
- [7] A. Bertucco and G. Vetter: "High Pressure Process Technology, Fundamentals and Applications," *Elsevier*, 2001.
- [8] M. Mukhopadhyay, "Natural Extracts Using Supercritical Carbon Dioxide," *CRC Press*, 2000.
- [9] R.B. Gupta and J.-J. Shim, "Solubility in Supercritical Carbon Dioxide," *CRC Press*, 2006.
- [10] P.G. Jessop and W. Leitner, "Supercritical Fluids as Media for Chemical Reactions," *Chemical Synthesis Using Supercritical Fluids*. pp. 1–36. *John Wiley & Sons*, 1999.
- [11] S. Zheng, X. Hu, A.-R. Ibrahim, D. Tang, Y. Tan, and J. Li, "Supercritical Fluid Drying: Classification and Applications," *Recent Patents on Chemical Engineering*, vol. 3, no. 3, pp. 230–244.
- [12] M. Saito, "History of supercritical fluid chromatography: Instrumental development," *Journal of Bioscience and Bioengineering*, vol. 115, no. 6, pp. 590–599, 2013.
- [13] Ž. Knez, M. Škerget, and M. Knez Hrnčič, "1 - Principles of supercritical fluid extraction and applications in the food, beverage and nutraceutical industries," In: Rizvi, S.S.H. (ed.) *Separation, Extraction and Concentration Processes in the Food, Beverage and Nutraceutical Industries*. pp. 3–38. Woodhead Publishing, 2013.
- [14] J.-I. Jung, J.Y. Bae, and B.-S. Bae, "Preparation and Characterization of Structurally Stable Hexagonal and Cubic Mesoporous Silica Thin Films," *Journal of Sol-Gel Science and Technology*. vol. 31, no. 1, pp. 179–183, 2004.
- [15] Ž. Knez, M. Pantić, D. Cör, Z. Novak, and M. Knez Hrnčič, "Are supercritical fluids solvents for the future?" *Chemical Engineering and Processing: Process Intensification*, vol. 141, pp. 107532, 2019.
- [16] Ž. Knez, M. Škerget, and M. Knez Hrnčič, "Principles of supercritical fluid extraction and applications in the food, beverage and nutraceutical industries." In: Rizvi, S.S.H.

- (ed.) *Separation, Extraction and Concentration Processes in the Food, Beverage and Nutraceutical Industries*. pp. 3–38. Woodhead Publishing, 2013.
- [17] C. Luetge, M. Bork, Z. Knez, and M. Kreiner, “Ultra high pressure dense gas extraction and fractionation,” in *Proceedings 5<sup>th</sup> International Symposium High Pressure Process Technologie Chemical Engineering*, 2007, pp. 1–4.
- [18] Ž. Knez, “Food Processing Using Supercritical Fluids,” In: Nedović, V., Raspor, P., Lević, J., Tumbas Šaponjac, V., and Barbosa-Cánovas, G.V. (eds.) *Emerging and Traditional Technologies for Safe, Healthy and Quality Food*, pp. 413–442. Springer International Publishing, 2016.
- [19] E. Lack and B. Simandi, “Supercritical fluid extraction and fractionation from solid materials,” *Industrial Chemistry Library*, vol. 9, pp. 537–575, 2001.
- [20] H. Wang, Y. Liu, S. Wei, and Z. Yan, “Application of response surface methodology to optimise supercritical carbon dioxide extraction of essential oil from *Cyperus rotundus* Linn,” *Food Chemistry*, vol. 132, no. 1, pp. 582–587, 2012.
- [21] E. Reverchon and I. De Marco, “Supercritical fluid extraction and fractionation of natural matter,” *Journal of Supercritical Fluids*, vol. 38, no. 2, pp. 146–166, 2006.
- [22] M.K. Hrnčić, D. Cör, M.T. Verboten, and Ž. Knez, “Application of supercritical and subcritical fluids in food processing,” *Food Quality Safety*, vol. 2, no. 2, pp. 59–67, 2018.
- [23] M.K. Hrnčić, D. Cör, and Ž. Knez, “Subcritical extraction of oil from black and white chia seeds with n-propane and comparison with conventional techniques,” *Journal of Supercritical Fluids*, vol. 140, pp. 182–187, 2018.
- [24] T. Vatai, M. Škerget, and Ž. Knez, “Extraction of phenolic compounds from elder berry and different grape marc varieties using organic solvents and/or supercritical carbon dioxide,” *Journal of Food Engineering*, vol. 90, no. 2, pp. 246–254, 2009.
- [25] A.B. Ortega, A.C. Garcia, E. Szekely, M. Škerget, and Ž. Knez, “Supercritical fluid extraction from saw palmetto berries at a pressure range between 300 bar and 450 bar,” *Journal of Supercritical Fluids*, vol. 120, pp. 132–139, 2017.
- [26] M. Ravber, Ž. Knez, and M. Škerget, “Simultaneous extraction of oil-and water-soluble phase from sunflower seeds with subcritical water,” *Food Chemistry*, vol. 166, pp. 316–323, 2015.
- [27] T. Gagić, Ž. Knez, and M. Škerget, “Subcritical Water Extraction of Chestnut Bark and Optimization of Process Parameters,” *Molecules*, vol. 25, no. 12, pp. 2774, 2020.
- [28] S. Jokić, T. Gagić, Ž. Knez, D. Šubarić, and M. Škerget, “Separation of active compounds from food by-product (cocoa shell) using subcritical water extraction,” *Molecules*, vol. 23, no. 6, pp. 1408, 2018.



- 
- [29] M. Ravber, Ž. Knez, and M. Škerget: "Isolation of phenolic compounds from larch wood waste using pressurized hot water: extraction, analysis and economic evaluation," *Cellulose*, vol. 22, no. 5, pp. 3359–3375, 2015.
- [30] S. Jokić, T. Gagić, Ž. Knez, M. Banožić, and M. Škerget: "Separation of active compounds from tobacco waste using subcritical water extraction," *Journal of Supercritical Fluids*, vol. 153, pp. 104593, 2019.
- [31] M. Čolnik, M. Primožič, Ž. Knez, and M. Leitgeb: "Use of non-conventional cell Disruption Method for extraction of Proteins from Black Yeasts," *Frontiers in Bioengineering and Biotechnology*, vol. 4, pp. 33, 2016.
- [32] P. Kotnik, M. Škerget, and Ž. Knez, "Supercritical fluid extraction of chamomile flower heads: comparison with conventional extraction, kinetics and scale-up," *Journal of Supercritical Fluids*, vol. 43, no. 2, pp. 192–198, 2007.
- [33] A. Perva-Uzunalić, M. Škerget, B. Weinreich, and Ž. Knez, "Extraction of chilli pepper (var. Byedige) with supercritical CO<sub>2</sub>: effect of pressure and temperature on capsaicinoid and colour extraction efficiency," *Food Chemistry*, vol. 87, no. 1, pp. 51–58, 2004.
- [34] B. Barjaktarović, M. Sovilj, and Ž. Knez, "Chemical composition of *Juniperus communis* L. fruits supercritical CO<sub>2</sub> extracts: dependence on pressure and extraction time," *Journal of Agricultural and Food Chemistry*, vol. 53, no. 7, pp. 2630–2636, 2005.
- [35] T. Perko, M. Ravber, Ž. Knez, and M. Škerget, "Extraction of curcuminoids from turmeric (*Curcuma longa* L.) with subcritical water," *Journal Tehnologica Acta*, vol. 9, no. 1, pp. 29–32, 2016.
- [36] L. Čretnik, M. Škerget, and Ž. Knez, "Separation of parthenolide from feverfew: performance of conventional and high-pressure extraction techniques," *Separation and Purification Technology*, vol. 41, no. 1, pp. 13–20, 2005.
- [37] D. Cör, T. Botić, Ž. Knez, U. Batista, A. Gregori, F. Pohleven, and T. Bončina: "Two-stage extraction of antitumor, antioxidant and antiacetylcholinesterase compounds from *Ganoderma lucidum* fruiting body," *Journal of Supercritical Fluids*, vol. 91, pp. 53–60, 2014.
- [38] A. Perva-Uzunalić, M. Škerget, Ž. Knez, B. Weinreich, F. Otto, and S. Grüner, "Extraction of active ingredients from green tea (*Camellia sinensis*): Extraction efficiency of major catechins and caffeine," *Food Chemistry*, vol. 96, no. 4, pp. 597–605, 2006.
- [39] K. Bizaj, M. Škerget, I.J. Košir, and Ž. Knez: "Sub- and Supercritical Extraction of Slovenian Hops (*Humulus lupulus* L.) Aurora Variety Using Different Solvents," *Plant*, vol. 10, no. 6, pp. 1137, 2021.

- 
- [40] T. Gagić, Ž. Knez, and M. Škerget: “Subcritical water extraction of horse chestnut (*Aesculus hippocastanum*) tree parts: Scientific paper,” *Journal of the Serbian Chemical Society*, vol. 86, no. 6, pp. 603–613, 2021.
- [41] T. Žitek, D. Borjan, A. Golle, Ž. Knez, and M. Knez, “Optimization of Extraction of Phenolic Compounds with Antimicrobial Properties from *Origanum vulgare*,” *Processes*, vol. 9, no. 6, pp. 1032, 2021.
- [42] L. He, X. Zhang, H. Xu, C. Xu, F. Yuan, Ž. Knez, Z. Novak, and Y. Gao: “Subcritical water extraction of phenolic compounds from pomegranate (*Punica granatum* L.) seed residues and investigation into their antioxidant activities with HPLC–ABTS+ assay,” *Food and Bioproducts Processing*, vol. 90, no. 2, pp. 215–223, 2012.
- [43] M. Hadolin, A.R. Hraš, D. Bauman, and Ž. Knez, “Isolation and concentration of natural antioxidants with high-pressure extraction,” *Innovative Food Science & Emerging Technologies*, vol. 5, no. 2, pp. 245–248, 2004.
- [44] M. Hadolin, M. Škerget, Ž. Knez, and D. Bauman, “High pressure extraction of vitamin E-rich oil from *Silybum marianum*,” *Food Chemistry*, vol. 74, no. 3, pp. 355–364, 2001.
- [45] M. Škerget, M. Bezjak, K. Makovšek, and Ž. Knez, “Extraction of Lutein Diesters from *Tagetes Erecta* using Supercritical CO<sub>2</sub> and Liquid Propane,” *Acta Chimica Slovenica*, vol. 57, no. 1, 2010.
- [46] M. Banožić, T. Gagić, M. Čolnik, Ž. Knez, M. Škerget, I. Jerković, and S. Jokić, “Sequence of supercritical CO<sub>2</sub> extraction and subcritical H<sub>2</sub>O extraction for the separation of tobacco waste into lipophilic and hydrophilic fractions,” *Chemical Engineering Research and Design*, vol. 169, pp. 103–115, 2021.
- [47] M. McHugh and V. Krukonis, “Supercritical Fluid Extraction: Principles and Practice.” *Elsevier*, 2013.
- [48] S.S. Kistler, “Coherent Expanded Aerogels and Jellies,” *Nature*, vol. 127, no. 3211, pp. 741–741, 1931.
- [49] N. Hüsing and U. Schubert, “Aerogels-Airy Materials, “Chemistry, Structure, and Properties,” *Angewandte Chemie International Edition*, vol. 37, no. 1–2, pp. 22–45, 1998.
- [50] M.A. Aegerter, N. Leventis, and M.M. Koebel eds: “Aerogels Handbook.” *Springer New York*, New York, 2011.
- [51] H. Sai, L. Xing, J. Xiang, L. Cui, J. Jiao, C. Zhao, Z. Li, and F. Li, “Flexible aerogels based on an interpenetrating network of bacterial cellulose and silica by a non-supercritical drying process,” *Journal of Materials Chemistry A*, vol. 1, no. 27, pp. 7963–7970, 2013.
- [52] S. Takeshita, S. Zhao, W.J. Malfait, and M.M. Koebel, “Chemistry of Chitosan Aerogels: Three-Dimensional Pore Control for Tailored Applications.” *Angewandte Chemie International Edition*, vol. 60, no. 18, pp. 9828–9851, 2021.

- 
- [53] H. Freundlich and H. Hatfield, "Colloid & capillary chemistry." *Methuen and Co. Ltd.*, 1922.
- [54] S. Üzer, U. Akman, and Ö. Hortaçsu: "Polymer swelling and impregnation using supercritical CO<sub>2</sub>: A model-component study towards producing controlled-release drugs," *Journal of Supercritical Fluids*. vol. 38, no. 1, pp. 119–128, 2006.
- [55] Y.K. Akimov, "Fields of application of aerogels (Review)," *Instruments and Experimental Techniques*, vol. 46, no. 3, pp. 287–299, 2003.
- [56] M.A. Aegerter, N. Leventis, and M.M. Koebel, "Aerogels Handbook," *Springer Science & Business Media*, 2011.
- [57] A. Berg, M.W. Droege, J.D. Fellmann, J. Klaveness, and P. Rongved, "Medical use of organic aerogels and biodegradable organic aerogels," *WO Patent*, 95, 01165, 1996.
- [58] R.J. Contolini, L.W. Hrubesh, and A.F. Bernhardt, "Aerogels for Microelectronic Applications: Fast, Inexpensive, and Light as Air." *Lawrence Livermore National Lab.*, CA (United States), 1993.
- [59] G.M. Pajonk, "Aerogel catalysts," *Applied Catalysis*, vol. 72, no. 2, pp. 217–266, 1991.
- [60] S.J. Kim, S.W. Hwang, and S.H. Hyun, "Preparation of carbon aerogel electrodes for supercapacitor and their electrochemical characteristics," *Journal of Material Science*, vol. 40, no. 3, pp. 725–731, 2005.
- [61] Z. Ulker and C. Erkey, "An emerging platform for drug delivery: Aerogel based systems." *Journal of Controlled Release*, vol. 177, pp. 51–63, 2014.
- [62] F. Schwertfeger, W. Glaubitt, and U. Schubert: "Hydrophobic aerogels from Si(OMe)<sub>4</sub>/MeSi(OMe)<sub>3</sub> mixtures," *Journal of Non-Crystalline Solids*, vol. 145, pp. 85–89, 1992.
- [63] F. Schwertfeger, N. Hüsing, and U. Schubert, "Influence of the nature of organic groups on the properties of organically modified silica aerogels." *Journal of Sol-Gel Science and Technology*, vol. 2, no. 1–3, pp. 103–108, 1994.
- [64] Pekala, Richard W, "Low density, resorcinol-formaldehyde aerogels," *US Patent*, US-A7406009, *Lawrence Livermore National Laboratory*, CA (USA), 1989.
- [65] H.-J. Huang, W.-K. Yuan, and X.D. Chen, "Microencapsulation Based on Emulsification for Producing Pharmaceutical Products: A Literature Review," *Developments in chemical engineering and mineral processing*, vol. 14, no. 3–4, pp. 515–544, 2006.
- [66] A.J. Domb, J. Kost, and D. Wiseman, "Handbook of Biodegradable Polymers." *CRC Press*, 1998.
- [67] C.A. García-González, M. Alnaief, and I. Smirnova, "Polysaccharide-based aerogels—Promising biodegradable carriers for drug delivery systems," *Carbohydrate Polymers*, vol. 86, no. 4, pp. 1425–1438, 2011.

- 
- [68] M.E.M. Braga, M.T.V. Pato, H.S.R.C. Silva, E.I. Ferreira, M.H. Gil, C.M.M. Duarte, and H.C. de Sousa: "Supercritical solvent impregnation of ophthalmic drugs on chitosan derivatives," *Journal of Supercritical Fluids*, vol. 44, no. 2, pp. 245–257, 2008.
- [69] A. López-Periago, A. Argemí, J.M. Andanson, V. Fernández, C.A. García-González, S.G. Kazarian, J. Saurina, and C. Domingo, "Impregnation of a biocompatible polymer aided by supercritical CO<sub>2</sub>: Evaluation of drug stability and drug–matrix interactions," *Journal of Supercritical Fluids*, vol. 48, no. 1, pp. 56–63, 2009.
- [70] A. Veronovski, Z. Novak, and Ž. Knez, "Synthesis and Use of Organic Biodegradable Aerogels as Drug Carriers," *Journal of Biomaterials Science, Polymer Edition*, vol. 23, no. 7, pp. 873–886, 2012.
- [71] A. Veronovski, Ž. Knez, and Z. Novak, "Preparation of multi-membrane alginate aerogels used for drug delivery," *Journal of Supercritical Fluids*, vol. 79, pp. 209–215, 2013.
- [72] A. Veronovski, Ž. Knez, and Z. Novak, "Comparison of ionic and non-ionic drug release from multi-membrane spherical aerogels," *International Journal of Pharmaceutics*, vol. 454, no. 1, pp. 58–66, 2013.
- [73] A. Veronovski, G. Tkalec, Ž. Knez, and Z. Novak, "Characterisation of biodegradable pectin aerogels and their potential use as drug carriers," *Carbohydrate Polymers*, vol. 113, pp. 272–278, 2014.
- [74] G. Tkalec, Ž. Knez, and Z. Novak, "PH sensitive mesoporous materials for immediate or controlled release of NSAID," *Microporous and Mesoporous Mater*, vol. 224, pp. 190–200, 2016.
- [75] E.M. Merisko-Liversidge and G.G. Liversidge, "Drug Nanoparticles: Formulating Poorly Water-Soluble Compounds," *Toxicologic Pathology*, vol. 36, no. 1, pp. 43–48, 2008.
- [76] G. Tkalec, Ž. Knez, and Z. Novak, "Fast production of high-methoxyl pectin aerogels for enhancing the bioavailability of low-soluble drugs," *Journal of Supercritical Fluids*, vol. 106, pp. 16–22, 2015.
- [77] G. Horvat, M. Pantić, Ž. Knez, and Z. Novak, "Encapsulation and drug release of poorly water soluble nifedipine from bio-carriers," *Journal of Non-Crystalline Solids*, vol. 481, pp. 486–493, 2018.
- [78] M. Pantić, Ž. Knez, and Z. Novak, "Supercritical impregnation as a feasible technique for entrapment of fat-soluble vitamins into alginate aerogels," *Journal of Non-Crystalline Solids*, vol. 432, Part B, pp. 519–526, 2016.
- [79] M. Pantić, P. Kotnik, Ž. Knez, and Z. Novak, "High pressure impregnation of vitamin D3 into polysaccharide aerogels using moderate and low temperatures." *Journal of Supercritical Fluids*, vol. 118, pp. 171–177, 2016.

- 
- [80] G. Horvat, K. Khanari, M. Finšgar, L. Gradišnik, U. Maver, Ž. Knez, and Z. Novak, "Novel ethanol-induced pectin-xanthan aerogel coatings for orthopedic applications," *Carbohydrate Polymers*, vol. 166, pp. 365–376, 2017.
- [81] M. Pantić, G. Horvat, Ž. Knez, and Z. Novak, "Preparation and Characterization of Chitosan-Coated Pectin Aerogels: Curcumin Case Study," *Molecules*, vol. 25, no. 5, pp. 1187, 2020.
- [82] M. Pantić, K.A. Kravanja, Ž. Knez, and Z. Novak, "Influence of the Impregnation Technique on the Release of Esomeprazole from Various Bioaerogels," *Polymers*, vol. 13, no. 11, pp. 1882, 2021.
- [83] Ž. Knez, Z. Novak, and M. Pantić, "CHAPTER 12: Incorporation of Drugs and Metals into Aerogels Using Supercritical Fluids." *Supercritical and Other High-pressure Solvent Systems*. pp. 374–394, 2018.
- [84] B.S.K. Gorle, I. Smirnova, M. Dragan, S. Dragan, and W. Arlt, "Crystallization under supercritical conditions in aerogels." *Journal of Supercritical Fluids*, vol. 44, no. 1, pp. 78–84, 2008.
- [85] B.S.K. Gorle, I. Smirnova, and W. Arlt, "Adsorptive crystallization of benzoic acid in aerogels from supercritical solutions," *Journal of Supercritical Fluids*, vol. 52, no. 3, pp. 249–257, 2010.
- [86] I. Smirnova, J. Mamic, and W. Arlt, "Adsorption of Drugs on Silica Aerogels," *Langmuir*, vol. 19, no. 20, pp. 8521–8525, 2003.
- [87] S.K. Rajanna, D. Kumar, M. Vinjamur, and M. Mukhopadhyay, "Silica Aerogel Microparticles from Rice Husk Ash for Drug Delivery," *Industrial & Engineering Chemistry Research*, vol. 54, no. 3, pp. 949–956, 2015.
- [88] M. Alnaief, S. Antonyuk, C.M. Hentzschel, C.S. Leopold, S. Heinrich, and I. Smirnova, "A novel process for coating of silica aerogel microspheres for controlled drug release applications." *Microporous and Mesoporous Materials*, vol. 160, pp. 167–173, 2012.
- [89] I. Smirnova, S. Suttiruengwong, and W. Arlt, "Feasibility study of hydrophilic and hydrophobic silica aerogels as drug delivery systems," *Journal of Non-Crystalline Solids*, vol. 350, pp. 54–60, 2004.
- [90] M. Alnaief and I. Smirnova, "Effect of surface functionalization of silica aerogel on their adsorptive and release properties." *Journal of Non-Crystalline Solids*, vol. 356, no. 33–34, pp. 1644–1649, 2010.
- [91] C.A. García-González, M. Jin, J. Gerth, C. Alvarez-Lorenzo, and I. Smirnova, "Polysaccharide-based aerogel microspheres for oral drug delivery." *Carbohydrate Polymers*, vol. 117, pp. 797–806, 2015.

- 
- [92] D.D. Lovskaya, A.E. Lebedev, and N.V. Menshutina, "Aerogels as drug delivery systems: In vitro and in vivo evaluations," *Journal of Supercritical Fluids*, vol. 106, pp. 115–121, 2015.
- [93] M.A. Marin, R.R. Mallepally, and M.A. McHugh, "Silk fibroin aerogels for drug delivery applications," *Journal of Supercritical Fluids*, vol. 91, pp. 84–89, 2014.
- [94] M. Betz, C.A. García-González, R.P. Subrahmanyam, I. Smirnova, and U. Kulozik, "Preparation of novel whey protein-based aerogels as drug carriers for life science applications," *Journal of Supercritical Fluids*, vol. 72, pp. 111–119, 2012.
- [95] V.S.S. Gonçalves, P. Gurikov, J. Poejo, A.A. Matias, S. Heinrich, C.M.M. Duarte, and I. Smirnova, "Alginate-based hybrid aerogel microparticles for mucosal drug delivery," *European Journal of Pharmaceutics and Biopharmaceutics*, vol. 107, pp. 160–170, 2016.
- [96] C.A. García-González and I. Smirnova, "Use of supercritical fluid technology for the production of tailor-made aerogel particles for delivery systems," *Journal of Supercritical Fluids*, vol. 79, pp. 152–158, 2013.
- [97] T. Mehling, I. Smirnova, U. Guenther, and R.H.H. Neubert, "Polysaccharide-based aerogels as drug carriers," *Journal of Non-Crystalline Solids*, vol. 355, no. 50–51, pp. 2472–2479, 2009.
- [98] I. Smirnova, S. Suttirungwong, and W. Arlt, "Aerogels: Tailor-made Carriers for Immediate and Prolonged Drug Release." *KONA Powder Part. J.* vol. 23, pp. 86–97, 2005.
- [99] G. Caputo, "Supercritical Fluid Adsorption of Domperidone on Silica Aerogel," *Advances in Chemical Engineering and Science*, vol. 03, no. 03, pp. 189–194, 2013.
- [100] I. De Marco and E. Reverchon, "Starch aerogel loaded with poorly water-soluble vitamins through supercritical CO<sub>2</sub> adsorption," *Chemical Engineering Research and Design*, vol. 119, pp. 221–230, 2017.
- [101] E. Weidner, Z. Knez, and Z. Novak, "Process for preparing particles or powders." *WO Patent*, 21688, pp. 17, 1995.
- [102] Y. Hakuta, H. Hayashi, and K. Arai, "Fine particle formation using supercritical fluids," *Current Opinion in Solid State and Materials Science*, vol. 7, no. 4–5, pp. 341–351, 2003.
- [103] M. Lubary, T.W. de Loos, J.H. ter Horst, and G.W. Hofland, "Production of microparticles from milk fat products using the Supercritical Melt Micronization (ScMM) process," *Journal of Supercritical Fluids*, vol. 55, no. 3, pp. 1079–1088, 2011.
- [104] A. Martín and M.J. Cocero, "Micronization processes with supercritical fluids: Fundamentals and mechanisms," *Advanced Drug Delivery Reviews*, vol. 60, no. 3, pp. 339–350, 2008.

- 
- [105] N. Elvassore, M. Flaibani, A. Bertucco, and P. Caliceti, "Thermodynamic Analysis of Micronization Processes from Gas-Saturated Solution," *Industrial & Engineering Chemistry Research*, vol. 42, no. 23, pp. 5924–5930, 2003.
- [106] M. Thereza, M.S. Gomes, D.T. Santos, M. Angela, and A. Meireles, "Trends in Particle Formation of Bioactive Compounds Using Supercritical Fluids and Nanoemulsions." *Food and Public Health*, vol. 2, no. 5, pp. 142–152, 2012.
- [107] G. Kravanja, Ž. Knez, P. Kotnik, B. Ljubec, and M. Knez Hrnčič, "Formulation of nimodipine, fenofibrate, and o-vanillin with Brij S100 and PEG 4000 using the PGSSTM process." *Journal of Supercritical Fluids*, vol. 135, pp. 245–253, 2018.
- [108] E. de Paz, A. Martin, and M.J. Cocero, "Formulation of  $\beta$ -carotene with soybean lecithin by PGSS (Particles from Gas Saturated Solutions)-drying." *Journal of Supercritical Fluids*, no. 72, pp. 125–133, 2012.
- [109] E. Weidner, "High pressure micronization for food applications," *Journal of Supercritical Fluids*, vol. 47, no. 3, pp. 556–565, 2009.
- [110] V. Salima, A. Martin, and M.J. Cocero, "Liposomal Incorporation of Lavandin Essential Oil by a Thin-Film Hydration Method and by Particles from Gas-Saturated Solutions," *Industrial & Engineering Chemistry Research*, vol. 50, no. 4, 2011.
- [111] J.P.M. Jung and M. Perrut, "Part 3: particles from gas-saturated solutions/suspensions (PGSS)," *Journal of Supercritical Fluids*, vol. 20, pp. 179–219, 2001.
- [112] C. Erkey and M. Türk, "Chapter 9 - Modeling of particle formation in supercritical fluids (SCF)." In: Erkey, C. and Türk, M. (eds.) *Supercritical Fluid Science and Technology*, pp. 239–259. Elsevier, 2021.
- [113] Z. Mandžuka, M. Škerget, and Ž. Knez, "High Pressure Micronization of Tristearate," *Journal of the American Oil Chemists' Society*, vol. 87, no. 2, pp. 119–125, 2010.
- [114] W. Chen, X. Hu, Y. Hong, Y. Su, H. Wang, and J. Li, "Ibuprofen nanoparticles prepared by a PGSSTM-based method," *Powder Technology*, vol. 245, pp. 241–250, 2013.
- [115] M. Fraile, D. Deodato, S. Rodriguez-Rojo, I.D. Nogueira, A.L. Simplício, M.J. Cocero, and C.M.M. Duarte, "Production of new hybrid systems for drug delivery by PGSS (Particles from Gas Saturated Solutions) process." *Journal of Supercritical Fluids*, no. 81, pp. 226–235, 2013.
- [116] E. Weidner, R. Steiner, and Z. Knez, "Powder generation from polyethyleneglycols with compressible fluids," In: von Rohr, Ph.R. and Trepp, Ch. (eds.) *Process Technology Proceedings*. pp. 223–228. Elsevier, 1996.
- [117] R.E. Sievers, Milewski, P.D., Sellers, S.P., B.A. Miles, B.J. Korte, K.D. Kusek, G.S. Clark, B. Mioskowski, and J.A. Villa, "Supercritical and Near-critical Carbon Dioxide Assisted Low-Temperature Bubble Drying," *Industrial & Engineering Chemistry Research*, vol. 39, no. 12, pp. 4831–4836, 2000.

- [118] J. Kerč, S. Srčič, Ž. Knez, and P. Senčar-Božič, "Micronization of drugs using supercritical carbon dioxide," *International Journal of Pharmaceutics*, vol. 182, no. 1, pp. 33–39, 1999.
- [119] A. Pestieau, F. Krier, P. Lebrun, A. Brouwers, B. Streel, and B. Evrard, "Optimization of a PGSS (particles from gas saturated solutions) process for a fenofibrate lipid-based solid dispersion formulation," *International Journal of Pharmaceutics*, vol. 485, no. 1, pp. 295–305, 2015.
- [120] S. Bánvölgyi, T. Vatai, Z. Molnár, I. Kiss, Ž. Knez, G. Vatai, and M. Škerget, "Integrated Process to Obtain Anthocyanin Enriched Palm-Fat Particles from Elderberry Juice," *Acta Alimentaria*, vol. 45, no. 2, pp. 206–214, 2016.
- [121] D. Meterc, M. Petermann, and E. Weidner, "Drying of aqueous green tea extracts using a supercritical fluid spray process." *Journal of Supercritical Fluids*, vol. 45, no. 2, pp. 253–259, 2008.
- [122] Z. Mandžuka and Ž. Knez, "Influence of temperature and pressure during PGSS<sup>TM</sup> micronization and storage time on degree of crystallinity and crystal forms of monostearate and tristearate." *Journal of Supercritical Fluids*, vol. 45, no. 1, pp. 102–111, 2008.
- [123] U. Feguš, U. Žigon, M. Petermann, and Ž. Knez, "Effect of drying parameters on physiochemical and sensory properties of fruit powders processed by PGSS-, Vacuum- and Spray-drying," *Acta Chimimica Slovenica*, vol. 62, no. 2, pp. 479–487, 2015.
- [124] T. Perko, M. Ravber, M. Škerget, and Z. Knez, "Isolation, characterization and formulation of curcuminoids and in vitro release study of the encapsulated particles," *Journal of Supercritical Fluids*, vol. 103, no. 48–54.



# Applying SCRUM in a Physics II Undergraduate Course: Effect on Student Progression and Soft Skills Development

Manolis Lourakis<sup>1,3</sup>, Konstantinos Petridis<sup>2,3</sup>

<sup>1</sup> PhD Candidate

<sup>2</sup> Associate professor

<sup>3</sup>Hellenic Mediterranean University, Department of Electronic Engineering, Romanou 3, Chania, Greece, 73100  
{lourakismanolis, c.petridischania}@gmail.com

**Abstract.** *The everchanging higher education environment, especially after the impact of COVID-19, dictates the need of innovative, engaging, and efficient teaching methods along with promoting soft skills among the students. Scrum offers a framework for effective teamwork and it has been previously applied in higher education for enhancing collaborative learning and the development of skills. This paper will describe how Scrum was applied to a Physics II undergraduate course during the spring semester 2021, where classes were given online due to covid-19 imposed restrictions. The focus of this experiment was twofold. Firstly, we aimed at investigating the feasibility of Scrum under remote teaching conditions. Secondly, we observed the students' progress with the learning objectives of the course, along with the advancement soft skills among the students participating in the experiment. We conclude our presentation with feedback collected both from the teachers and the students involved in the experiment.*

**Keywords.** Scrum, active learning, collaborative learning, soft skills, remote teaching, group project

## 1 Introduction

As the Future of Jobs report 2020 states, the relative importance of critical thinking and analysis along with self-management and working with people skill groups, are of increasing importance among companies worldwide [6]. Among the plethora of skill groups described in the report, the self-management skill group emerges as the most wanted in industry, since it encompasses skills such as active learning, resilience, stress tolerance and flexibility. Research has already stated the importance of these skills for career success [7], while most recent investigation identifies the soft skills gap between the Higher Education-HE and Employability [8]. Education 4.0 addresses these skills gaps so the future work force can be able to respond on the needs of the 4<sup>th</sup> industrial revolution. [9]. The nine trends of Education 4.0 dictate among other, that must be a shift to the major responsibilities from the instructor to the learners, and that learning can take place anytime anywhere through e-Learning tools.

University graduate students should be ready to function in a specific and highly competitive working environment. They would be creative and critical thinkers, be able to negotiate and communicate their work, be team players, they should have substantial management skills and be able to facilitate learning in groups and communities. However, University graduates require far more personal skills, complementing their discipline expertise, than is recognized in today's mainstream education [10]. Most of the soft skills are not considered at all in the present curricula, and disciplines [11]. This does not mean the replacement of disciplinary courses with soft skills courses but the integration of new way of teaching that will cultivate the aforementioned soft skills through the hard skills courses. New innovative pedagogies and learning frameworks must be adapted by the Universities to facilitate the capacity of 'ideal' graduates to integrate across disciplines and skills (hard and soft skills). All the above facts gave inspiration for the implementation of the Agile tool of Scrum, in remote teaching conditions, so to investigate the overall benefits to the students from this different pedagogy concept. In this study, the application of Scrum within the framework of the Physics II module incorporates many components of soft skills development (for both of students and trainers), (a) action research as a research method; (b) facilitation concepts & techniques; (c) process management, planning; (d) knowledge management; (e) communication skills; (f) team skills, team management, team building; (g) facilitating learning processes; and (k) process consultation and coaching skills.

Agile methodologies are proven to be effective in higher education as teaching/learning practices based on the best concepts and ideas from the field of software engineering and software development [11]. Especially the Scrum framework is proven to facilitate the level of engagement required in group projects even when applied in HE teaching and learning processes, mainly because it enables active learning and self-management [2-5][13]. In active learning concept, the learners are responsible for their own learning [14-18] and this practice is well served by the principles of the agile manifesto since it values student-driven inquiry and continuous improvement among other values [19]. On a parallel concept, Scrum as an agile framework, can cultivate soft skills among other hard disciplined knowledge, to the group that use it, as it will be shown in this paper. The main challenge of the Scrum

application was the remote teaching conditions during the semester due to covid-19 restrictions. Additional challenge imposed by the idea of applying Scrum, exactly as described in the updated in 2020, Definitive Scrum guide [20] by Ken Schwaber & Jeff Sutherland, a fact that was not evident in previous works on the subject [3-5]. The diversions from the Definitive Scrum Guide were as follows:

- Daily Scrum meetings didn't happen every working day.
- Not clear presentation of the construction of the Product Backlog.
- Sprint retrospect meetings were not held.
- Delivery of increments in between the Sprints and not in the Sprint Review.
- Unclear references to the Sprint Planning meeting.

For that, was imperative to us to prove that the Definitive Scrum guide can be applied as is in the HE Institutions without special training. Additional task was to introduce to the students the actual framework that they will most likely meet in their future working environment, since the electronic engineering sector involves project teamwork and software development. Besides the above-described goals, a soft skill enhancement of the students, was desired, through the insufflation of the core pillars values of scrum and adherence to the framework's roles and events.

## 2 Background and Motivation

### 2.1 Scrum framework pillars and values

Scrum framework encompasses both the objectives of active learning and engagement since it engages groups of people who collectively have all the skills and expertise to do the work and share or acquire such skills as needed [20]. Paramount importance have the three pillars and the five values, that must be embraced in parallel with the three roles, the five events and the three artifacts. First pillar is the transparency of the work that will lead to the second pillar of inspection which in turn will drive the third pillar of adaptation. The whole organization must adhere to the three pillars for the Scrum to be effective and successful. The five values must be embraced by the scrum team and these values are openness, respect, courage, focus and commitment.

### 2.2 The three roles

The scrum team consist of the Product Owner, the Scrum Master, and the Developers, which are the three roles of scrum.

Product Owner is the sole responsible for the outcome and he is the voice of the customer that sets the vision and the priorities for the product goal. Scrum Master is a leader who serves and oversees the application of scrum in all levels of the organization. His purpose is to facilitate the application of the framework and the continuous improvement of the developer's team. Developers as the last role, is the group of people that perform the work

towards the completion of the product. The members are cross-functional and possess all the skills needed to do the work. They are self-managed with no actual leader, and they decide collectively on every aspect of the work to be done, following the iterative manner of the five events.

### **2.3 Scrum events**

The project starts with the event of Sprint planning meeting where the scrum team under the direction of the product owner, comprises the product backlog which is the list of to-do items for the whole project. After the construction of the Product backlog, they collectively decide when the project is considered finished by stating the Definition of Done. Then the team decides which of the Product Backlog items will be worked in the upcoming sprint and this smaller list is the Sprint Backlog. After this meeting the work starts for a predefined period called the Sprint, the main event and heart of scrum. At the beginning of each workday the third event happens under the directions of the scrum master, and this is the Daily Scrum. It is a meeting that should last less than 15 minutes, and the purpose is for the scrum master to remove any impediments the team may encounter and after a short discussion with the developers, to re-plan or adapt the work for the rest of the day. The sprint outcome is reviewed by the team, in the event called Sprint Review, where after inspection and assessment of the completed work, it will be decided if a product Increment is produced. The fifth event is the Sprint Retrospect which closes the iteration circle of the scrum. In this meeting which is held with the developers and the scrum master only, the scope is to discuss the tools, processes and interactions that took place during the sprint, in order to decide which to keep and which to discard for the team to improve in the next sprint. In each iteration happens the production of the three artifacts. The iteration cycle of Scrum is depicted on Fig. 1

### **2.4 Scrum artifacts**

The very first one, The Product Backlog is the written form of the vision and the priorities that lead to the final product. Although this is decided at the first Sprint Planning it can and must be refined in each cycle. Product Owner is responsible for the prioritization of the items listed there but every team member can add items at any time. Only the Product Owner can delete items from the Product Backlog. The second artifact is the Sprint Backlog; a subset of the Product backlog. The last artifact is the sum of the completed work of each sprint, that gives value and leads to the Definition of Done as it was stated in the Sprint Planning. The Product Backlog is the tool for setting the learning outcomes of the project and the self-organization and self-management of the scrum team is the drive for the participants to engage actively not only to the accomplishment of the learning objectives but also for the cultivation of parallel soft skills, along the project evolution. The iterative nature of the framework's ceremonies along with the constant inspection, feedback, and adaptation, gives the students the opportunity to learn by their own mistakes and adapt accordingly for their next sprint review.

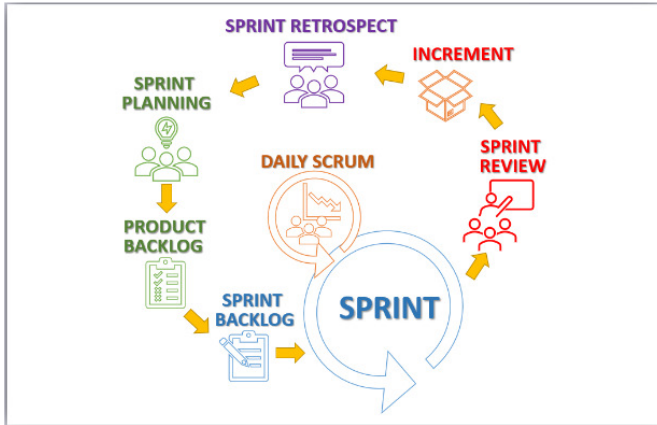

Figure 1. Scrum iteration cycle

### 3 Methodology

#### 3.1 Description

The project was conducted in a voluntary basis in the undergraduate Physics II course of the second semester of the Electronics Engineering School of the Hellenic Mediterranean University of Greece. The novelty was in the remote implementation of the framework since remote teaching conditions were imposed due to covid-19 pandemic lockdown. The main objective was for the students not only to learn physics’ concepts and laws but also to be able to link them with real electric and electronic devices, using the Scrum framework. Secondary objective was to create a bigger engagement from them -concerning their online lectures- by transferring onto them the responsibility of their learning. The way towards that goal was through cooperation, collaboration, and research in self-managed group of peers as the scrum framework advocates. After a comprehensive online lecture about the scrum guide and the framework, ten students enrolled for the project, knowing that this project was on top of any other obligation in the university and that they will be given extra credit only if they pass the course final exams given in the conventional way for the online teaching as the rest of the classroom. The project was conducted in two phases throughout the semester, with two different team setups for each phase to evaluate the feasibility of scrum events in a nonstandard team composition. The role of the Product Owner was taken by the teaching professor of the class and the role of the Scrum Master was taken from a PhD student of the same professor.

### **3.2 Developers**

Three teams were made for the first phase, with three students in the first two teams and four students in the third team. The division was made by the Scrum Master (PhD student) so to incorporate in each team different levels of knowledge/experiences, since the participants were from different semesters. In the second phase, two teams were comprised from the remaining nine students with four and five students respectively in each team. Effort was made to mix the members of each team of the first phase, with members from other teams so to investigate the team interactions and effects on collaborative learning.

### **3.3 Final Product**

The final product of the first phase was a 45-minute presentation explaining the function of an electronic/electric device that relies on the concepts and theory of the backlog items. Each of the three teams had a different device to describe and the Definition of Done from the Product Owner (the professor) was to explain the function of the device using terms and meanings of the related physics course and not with popular science terms. For the second phase, both teams were asked to deliver a 45-minute presentation of the same electric device, again with the same obligation of explaining the function of the device by relating its features with the physics principles they have learned.

### **3.4 Product Backlog**

The framework dictates that the scrum team along with the stakeholders, must create the product backlog in the very first sprint planning event. Instead of that, the backlog was constructed by the Product Owner and was given ready to the Developers to accomplish in the upcoming sprints. The long-term reason for that was to assure that all the participants were given the correct learning objectives for this project and because the backlog items must have been identical with the main physics II topics that were taught remotely during the semester. In that way the teams would have at least one source of information about their project. Another reason for the ready-made product backlog was the coherence of the required learning objectives between the two phases of the project and the coherence with the course syllabus.

### **3.5 Sprint Backlog**

Each team of decided on which items from the product backlog they will focus for the next sprint, and this was the Sprint Backlog. The goal for each team was to learn, understand and be able to teach in a simplified manner, the items of the backlog. The way for achieving this goal was left to the teams itself with the advice from the product owner, to also attend the online lectures of the course, as a valuable source of information about their project.

### **3.6 Artifacts**

Apart from the Product Backlog that was prepared by the professor, all the teams should make a Sprint Backlog for each sprint at the Sprint Planning meeting, that is held at the beginning of each Sprint. The items in the Sprint Backlog were chosen from the Product Backlog as per team's desire. The last required artifact was the Increments which in our project case was a proof of gained knowledge during the sprint.

### **3.7 Increments**

For the teams to prove that they have gained the necessary knowledge during each sprint, they were asked to provide a 30-minute presentation in each Sprint Review meeting, explaining all the items in the sprint backlog, in a teaching manner. The purpose for that was to evolve each team member's soft skills in communication, collaboration, critical thinking, and deadline keeping. For succeeding in the latter, a burndown chart was required in each daily scrum meeting, to be filled according to the sprint's work completion.

### **3.8 Sprint Planning Meetings**

This crucial ceremony for the scrum framework was organized through teleconference session in pre-planned dates, at the beginning of each new sprint. For educational purposes and time efficiency, a single meeting was held for all the teams so each participant student could gain valuable experience on the way other people think, talk and behave on an online meeting, where important decision should be made collaboratively and with consensus.

### **3.9 Sprint Structure**

The first phase was divided into three sprints of fourteen days each as per Table 1, and the secondary objective was to guide the students into PowerPoint presentation making and proper ways of presenting remotely their work. The guidance was done by the Scrum Master incrementally in each daily scrum meeting by advising and pointing to the right sources for research. The Scrum Master didn't supervise each team's work (with the classical meaning of the term) because the primary objective remained and was the cultivation of self-learning, self-managing, collaborative learning and engagement, actions that lead directly to the active learning concept [13]. He only helped them stay in the right research direction, allowing small deviations for educational purposes. Besides that, Scrum Master provided incentives and posed theoretical questions to the teams, to improve their critical thinking and analysis, from one daily scrum meeting to the next. In the second phase there was only one sprint period which lasted three weeks, from 10<sup>th</sup> of May 2021 until 28 of May 2021. The reason for scheduling only one sprint was that of discovering how do they perform in longer deadlines, without the feedback of multiple sprint review meetings before the final delivery of the product.

**Table 1.** Start and end dates for the three scheduled sprints of the 1st phase

<b>Sprint</b>	<b>Start Date</b>	<b>End date</b>
Sprint 1	8 March 2021	21 March 2021
Sprint 2	26 March 2021	9 April 2021
Sprint 3	12 April 2021	24 April 2021

### 3.10 Daily Scrum Meetings

As the official scrum guide dictates [20], at the beginning of each working day a daily scrum meeting with the scrum master should take place so to track completed and remaining work, interactions, and problems the team may encounter. Due to the self-managed feature of the scrum teams, each team decided to work in different time slots during the week so to accommodate every team member's need for the rest of the semester enrolled courses. The daily scrums were taken place at the beginning of the working day of each team and the duration was depended on the team's needs but never exceeded half an hour. For both the phases, each team was encouraged to provide a weekly schedule of the next week which stated the days and time windows where the project work should take place. This was not a scrum artifact but solely a helping aid for coordination between the scrum master and the developer teams.

### 3.11 Sprint Review Meetings

The event of the Sprint Review was held in Zoom online tool with all the teams virtually present during each team's 30-minute sprint presentation. The aim of each presentation was for each team, to demonstrate in a teaching lecture manner their level of understanding of the Backlog Items they had chosen. The Developers were encouraged to choose their own way of presenting their work but with a set of criteria given by the Product Owner. Through these assessment criteria the students were able to prepare their presentation by their own means and without the intervention of the Scrum Master or the Product Owner. Each online presentation was followed by a 30-minute Q & A period where the professor asked each team member, key questions about the content of their presentation, to assess the level of understanding on each physics law or concept that was presented and is linked with the operation the device was targeted. Members from other teams were permitted to ask questions to the presenting team for exchanging ideas and provoking a discussion on the subject of the presentation.

### 3.12 Sprint Retrospective Meetings

This important event for team's evolution was held the next day of the Sprint review, separately for each team and the focus was on how the team members interacted during the sprint. Also, there was a discussion on the way the group worked in terms of Product Backlog



---

items research and handling. By encouragement of the Scrum Master, the students decided by consensus if the methods and tools used the previous sprint are suitable for the next one.

## 4 Results

In the very first Sprint Planning meeting, all the students together, decided that the most suitable platform for this online experience is the popular Discord. It is designed for virtual interaction between people with common interests in video games, available for personal computers and all kinds of smart handheld devices like smartphones and tablets. It is free of charge and the overall setup of the application in text and voice channels, made it ideal for the purposes of the project. With the help of the most experienced in Discord student, all teams created their own virtual working space, the Scrum server, with virtual rooms inside it, that suited the needs of each team.

The application offers the possibility of voice and video interaction between members on the click of a mouse button, and the upload/download of any kind of digital file up to certain size, depending on the type of the file. It also offers the share screen function that proved valuable when one student was presenting his finding on a Product Backlog item, to the other team members. In this first Sprint Planning and on each subsequent one, there were two distinct processes that took place. The first was the construction of the Sprint Backlog in which each team, decided which Product Backlog items will be included in this sprint work. The second process and most difficult one, was to decide by estimation, how many hours will need for each item to complete. The sum of those hours, called the Sprint effort was put on the vertical axis of the Burndown chart, where the calendar days of the Sprint were on the horizontal axis.

Daily scrum was conducted on each working day, in the Discord platform for discussing the three questions of the Daily scrum. Each team had its own pace of work, which was decreasing through the 1<sup>st</sup> phase of Scrum, as Table 2 shows. Right at the start of the Daily Scrum, the team presented the updated Burndown chart like in Fig 2, where a small discussion was made on the progress of the team's work. The preferred method of presenting the chart was the MS Excel spreadsheet which offered flexibility of correcting and updating the chart remotely using cloud services. Afterwards and according to the guide [20], the Scrum master asked each team member individually, in the presence of the whole team, what he have done the previous working day, what he will do this day and if there are any problems impeding his work.

The duration of Daily Scrums averaged 30 minutes and that was due to the coaching done by the Scrum Master, after finishing the typical Scrum obligation of the three questions to each student. This coaching was deemed necessary to help the students enhance their soft skills of digital literacy, communication, decision making, critical thinking, research methodology and time keeping. The way of coaching was through pointing to the right source in the literature for them to investigate and not by answering directly to the emerging questions. The increments produced in the 1<sup>st</sup> phase of the project, were six PowerPoint

presentations that were presented, in the 1<sup>st</sup> and 2<sup>nd</sup> Sprint Review. The 2<sup>nd</sup> phase had no increments because there was only one Sprint with the final Product delivered at the end of it. Five Products were delivered in total and were again PowerPoint presentations according to the Product Backlog. 65 Burndown charts was produced by the students, indicating the total hours they spent on the project.

The hours assigned by estimation on each Sprint, were different for each team as per Table 3. During the Q/A sessions that followed each presentation of an Increment, the teams were asked how they estimated the number of hours for the Sprint, and the answer by all the teams was by deliberation, without following any specific methodology. That led Team 1 on estimating more hours than needed and Team 2 the exact opposite. Only Team 3 managed to estimate quite accurately the amount of effort needed for each Sprint.

**Table 2.** 1st phase’s working days per Sprint, per team

	No Scrum	Scrum	Total
Enrolled students			137
Participants in final exam	92	8	100
Pass within participants	31	5	36
Success rate	34%	63%	36%
Average final exam grade	3.8	6.7	4.0

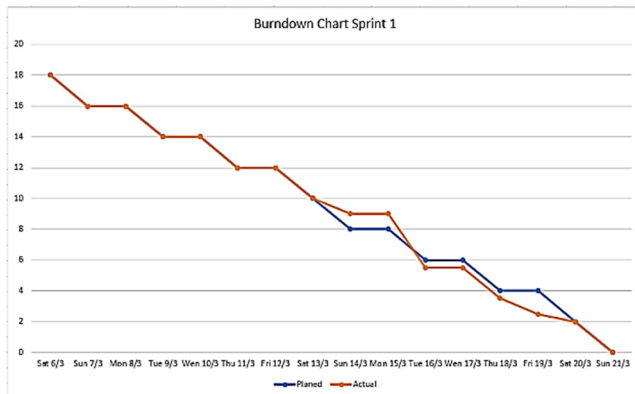

**Figure 2.** Burndown chart

As it was stated earlier in this paper, this effort was additional to the conventional effort of the class taught online. The end of the project coincided with the end of the semester, where the Scrum students undertook the final exams like the rest of the enrolled students. The grade system on the Hellenic Mediterranean University, where this study was conducted, qualifies a score of above five out of ten, as a pass score. The overall exams result of the whole class are shown on Table 4. For comparison reasons the enrolled students divided into three categories, those who participated on the Scrum project, those who didn’t and the total students. Fig. 3 presents the final exam grades distribution per category.

**Table 3.** Sprint effort in hours for each team

		Team 1	Team 2	Team 3
1 <sup>st</sup> Phase	Sprint 1	30	13	21
	Sprint 2	35	16	20
	Sprint 3	26	18	20
		Team “Generator”	Team “Full House”	
2 <sup>nd</sup> Phase	Sprint 1	22	20	

**Table 4.** Exams results of the Physics II course

Sprint	Team 1	Team 2	Team 3
1 <sup>st</sup>	6	5	8
2 <sup>nd</sup>	5	5	6
3 <sup>rd</sup>	5	3	5

After the end of the semester, the participants were asked for their feedback on the Scrum experience, through an online questionnaire with 23 questions. The most significant responses are shown to Fig. 4 to 7.

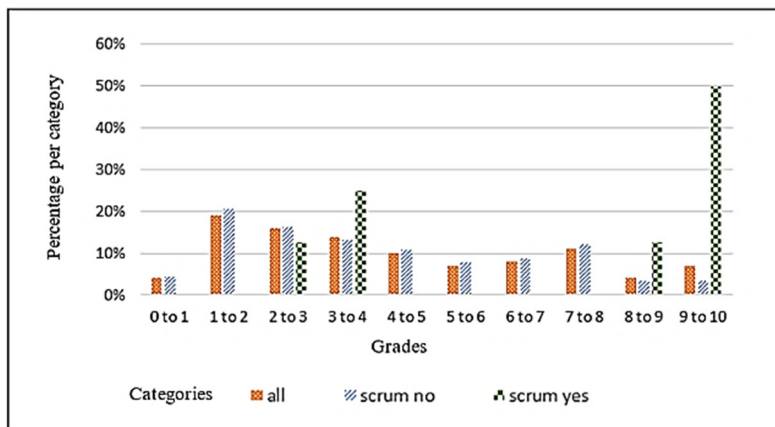

**Figure 3.** Grades distribution

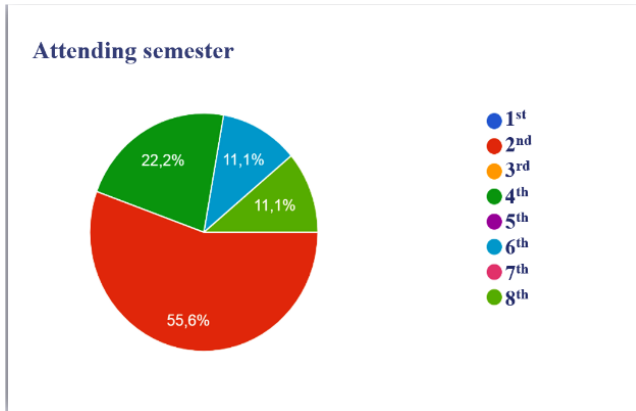

Figure 4. Attending semester distribution among Scrum participants

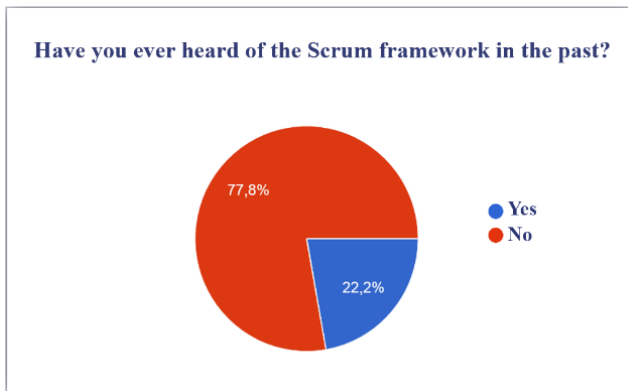

Figure 5. Student's awareness on Scrum framework

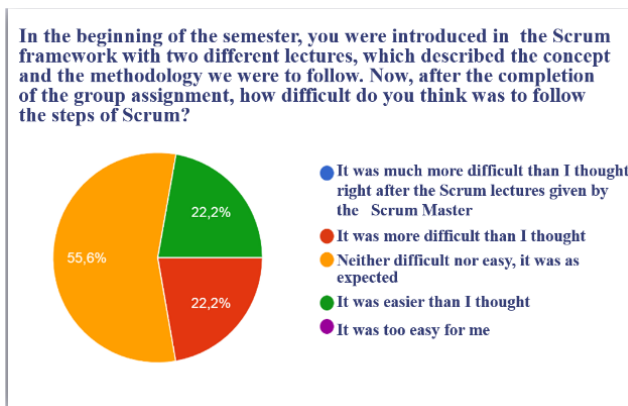

Figure 6. Perceived difficulty of Scrum framework

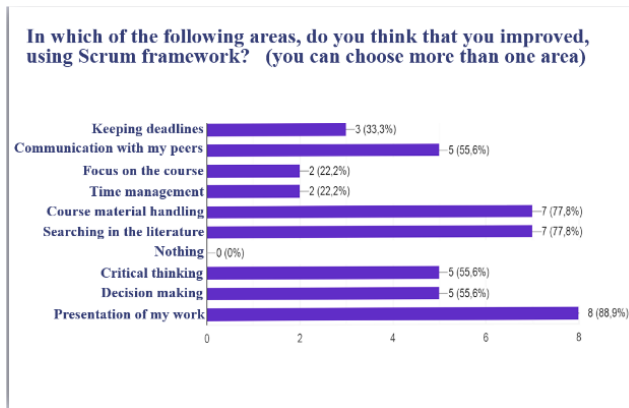

Figure 7. Participant’s perceived evolution on soft skills

## 5 Discussion

The engagement of the students on the Scrum project was apparent from the first Sprint Planning where they cooperated to decide what platform to use for their meetings and work. This engagement remained constant throughout the project since there were only two instances where a student of each team was absent, on a total of 48 Daily Scrums on the 1<sup>st</sup> phase. The three Scrum questions posed by the Scrum Master in each Daily Scrum to each team member, provided the Scrum Master a way of documentation of the progression of each member on embracing the values of Scrum. Although in the beginning was difficult for some students to express themselves openly, by the frequent iteration of the Daily Scrums, the value of openness was more and more embraced by all the students. This openness led them to receive and give respect among the team, which in turn drove them to have the courage to admit shortcomings and personal defects that affected the team’s work. But the most evident evolution on student’s behavior was the commitment they showed to the task, during the project. This commitment and focus were observable through the frequent virtual visits of the Scrum Master, on the Discord Platform, where he was able to silently watch the teams working in their respective space. Another task that proved difficult was that of predicting the work needed for the Sprint Backlog items.

Two teams were unsuccessful on precisely estimating their effort in the beginning of each sprint, but this was not a problem since the dynamic nature of Scrum permits corrections and adaptations to every action made towards the Sprint goal. Both the Product Owner and The Scrum Master witnessed the performance of the students on the presentation of their work, on each Sprint Review, which varied from adequate in the first meetings to very good at the end of the project. The evolution on their presentation skills was due to the repetitive process of Sprint Reviews and the feedback from the Product Owner, who was also the professor delivering the course.

At the same time, the professor evidenced the progression on their acquired knowledge, though their responses to the oral questions he posed in each student individually, in every Sprint review. The questions were according to the course's learning outcomes, in an increasing difficulty manner, throughout the progression of the project. This fact was ultimately proved true from the exam results of the students participated on the Scrum project, as shown on Table IV. On top of that, the grades the Scrum students achieved were higher in percentage, than the grades of the rest of the class. Although the teams didn't produce the Product Backlog, the artifact of Sprint Backlog was correctly created from all the teams, since they managed to deliver the backlog items on the end of each Sprint. The last artifact of the Sprint increments, which were the half an hour presentation, evaluated as of ascending quality by the Product Owner and the Scrum Master.

## 6 Conclusions

The engagement of the students on the Scrum project was apparent from the first Sprint Planning where they cooperated to decide what platform to use for their meetings and work. This engagement remained constant throughout the project since there were only two instances where a student of each team was absent, on a total of 48 Daily Scrums on the 1<sup>st</sup> phase. The three Scrum questions posed by the Scrum Master in each Daily Scrum to each team member, provided the Scrum Master a way of documentation of the progression of each member on embracing the values of Scrum. Although in the beginning was difficult for some students to express themselves openly, by the frequent iteration of the Daily Scrums, the value of openness was more and more embraced by all the students. This openness led them to receive and give respect among the team, which in turn drove them to have the courage to admit shortcomings and personal defects that affected the team's work. But the most evident evolution on student's behavior was the commitment they showed to the task, during the project. This commitment and focus were observable through the frequent virtual visits of the Scrum Master, on the Discord Platform, where he was able to silently watch the teams working in their respective space. Another task that proved difficult was that of predicting the work needed for the Sprint Backlog items.

Two teams were unsuccessful on precisely estimating their effort in the beginning of each sprint, but this was not a problem since the dynamic nature of Scrum permits corrections and adaptations to every action made towards the Sprint goal. Both the Product Owner and The Scrum Master witnessed the performance of the students on the presentation of their work, on each Sprint Review, which varied from adequate in the first meetings to very good at the end of the project. The evolution on their presentation skills was due to the repetitive process of Sprint Reviews and the feedback from the Product Owner, who was also the professor delivering the course.

At the same time, the professor evidenced the progression on their acquired knowledge, though their responses to the oral questions he posed in each student individually, in every Sprint review. The questions were according to the course's learning outcomes, in an

increasing difficulty manner, throughout the progression of the project. This fact was ultimately proved true from the exam results of the students participated on the Scrum project, as shown on Table IV. On top of that, the grades the Scrum students achieved were higher in percentage, than the grades of the rest of the class.

Although the teams didn't produce the Product Backlog, the artifact of Sprint Backlog was correctly created from all the teams, since they managed to deliver the backlog items on the end of each Sprint. The last artifact of the Sprint increments, which were the half an hour presentation, evaluated as of ascending quality by the Product Owner and the Scrum Master.

## References

- [1] Oya Tamtekin Aydin, "Current developments and trends in higher education," *Journal of Business, Economics & Finance* ISSN: 2146 – 7943, Vol. 3, Iss. 4,2014
- [2] Scrum Manifesto, [www.scrummanifesto.org](http://www.scrummanifesto.org) (accessed June 25, 2021)
- [3] Mia Persson, Ivan Kruzela, Kristina Allder, Olof Johansson and Per Johansson, "On the Use of Scrum in Project Driven Higher Education", *ResearchGate.net*, 2012
- [4] Antonio Jurado-Navas & Rosa Munoz-Luna "Scrum Methodology in Higher Education: Innovation in Teaching, Learning and Assessment" *International Journal of Higher Education*, Vol. 6, No. 6, 2017
- [5] Hwai-Jung Hsu, Eason Lin, Kiki Chang, Elton Hsiao, "Practicing Scrum in Institute Course", *Proceedings of the 52nd Hawaii International Conference on System Sciences*, 2019
- [6] World Economic Forum "The Future of Jobs Report 2020", <https://www.weforum.org/reports/the-future-of-jobs-report-2020> (accessed June 25, 2021)
- [7] Shaheen Majid, Zhang Liming, Shen Tong, Siti Raihana, "Importance of Soft Skills for Education and Career Success", *International Journal for Cross-Disciplinary Subjects in Education (IJCDSE)*, Special Issue Volume 2 Issue 2, 2012
- [8] Ms. Charu Sarin, "Analyzing Skill Gap between Higher Education and Employability", *Research Journal of Humanities and Social Sciences*, October 2019
- [9] Anealka Aziz Hussin, "Education 4.0 Made Simple: Ideas For Teaching", *International Journal of Education & Literacy Studies*, 2018
- [10] Patel, K. B., Maina, M., Haggmann, J. and Woomer, P. L.. "Curriculum development and transformation in rural development and natural resource management: a strategy workshop." Conducted at the Rockefeller Foundation's Bellagio Center in Italy, November 12–16, 2001.

- [11] Moyo, E. and Hagmann, J., “Facilitating competence development to put learning process approaches into practice in rural extension.” In *FAO: Human resources in agricultural and rural development*. Rome: FAO, pp. 143-157, 2000
- [12] Andy Hon Wai CHUN, “The Agile Teaching/Learning Methodology and its e-Learning Platform”, *Lecture Notes in Computer Science-Advances in Web-Based Learning Volume 3143*, Springer-Verlag Heidelberg, pp. 11-18, 2004
- [13] Marco Klopp et al., “Totally Different and yet so Alike – Three Concepts to Use Scrum in Higher Education”, *ECSEE '20*, 2020
- [14] Michael Norbert et al., “Active Versus Passive Teaching Styles: An Empirical Study of Student Learning Outcomes”, *Human Resource Development Quarterly*, vol. 20, no. 4, Winter 2009
- [15] Freeman et al., “Active learning increases student performance in science, engineering, and mathematics”, *PNAS*, VOL111, no 23, 2014
- [16] Theobald et al., “Active learning narrows achievement gaps for underrepresented students in undergraduate science, technology, engineering, and math”, *PNAS*, vol 117, no 12, 2020
- [17] Louis Deslauriers, Logan S. McCarty, Kelly Miller, Kristina Callaghan and Greg Kestin, “Measuring actual learning versus feeling of learning in response to being actively engaged in the classroom”, *PNAS*, VOL116, no 39, 2019
- [18] Charles C. Bonwell, James A. Eison, “Active Learning: Creating Excitement in the Classroom”, *ASHE-ERIC Higher Education Reports*, 1991
- [19] Krehbiel et al, “Agile Manifesto for Teaching and Learning”, *The Journal of Effective Teaching*, Vol. 17, No.2, 90-111, 2017
- [20] Ken Schwaber & Jeff Sutherland, “The scrum guide-The Definitive Guide to Scrum: The rules of the game”, 2020, <https://scrumguides.org/docs/scrumguide/v2020> (accessed June 25, 2021)



# Development of an Inclusive Multiplayer Serious Game for Deaf and Blind

Nuno Neto<sup>1</sup>, Bruno Galasso<sup>2</sup>, Dirceu Esdras<sup>2</sup>, Paula Escudeiro<sup>1</sup>

<sup>1</sup> Games, Interaction and Learning Technologies R&D Center, Instituto Superior de Engenharia do Porto, Rua Dr. António Bernardino de Almeida, 431, 4249-015 Porto, Portugal

nunoarneto@gmail.com, pmo@isep.ipp.pt

<sup>2</sup> Instituto Nacional de Educação de Surdos, Rua das Laranjeiras, 232, 22240-003 Rio de Janeiro, Brasil

{galasso.bruno, diresdras}@gmail.com

**Abstract.** *The paper presents the development of an inclusive serious multiplayer game with Morse code as its theme, as well as describing methodologies and architectures for developing a serious game through specific concepts for the deaf (sign language) and blind (audio description). The preceding case has three game modes: classic one versus one, a cooperative mode between two players and a four-player game mode all. To validate this serious game performance and quality, a Quantitative Evaluation Framework was used. In that context, the final product has three dimensions: pedagogical, ergonomic, and technical. From the obtained data, it was possible to conclude that this game was proof that using accessibility guidelines during software development helps to promote not only an efficient integration of excluded communities, but also social inclusion and equity between players.*

**Keywords.** Serious games, accessibility, bloom cognitive model, development methodologies, assistive technology

## 1 Introduction

Promote equal opportunities and social inclusion for people with disabilities is a concern of modern societies (FCT/ COMPETE2020 – project ACE<sup>1</sup> ref: PTDC/IVC-COM/5869/2014, POCI-01-0145-FEDER-016584). Science evolution and new available technologies allowed for the development of solutions to chronic problems, such as effective communication by digital means with the deaf (sign language) or blind (braille) people.

As reported by the World Health Organization [1], the number of people with visual impairment or blindness is 2.2 billion worldwide, while people with hearing loss is 466 million [2]. In Portugal, according to the 2011 censuses, there are nearly 533.000 people with hearing problems, and it is estimated -in accordance with information provided by Serviin (Video interpretation service provided by the Deaf Citizen Portal) that 120.000 are born-deaf or became deaf in early childhood [3].

Within this context, most of the population suffers from a lack of accessibility means, hence digital literacy has become increasingly relevant. Education, another critical area, presents even more worrying data. Education barriers faced by people with specific needs limit future opportunities, resulting in inequality. Any contribution to eliminating this inequality promotes equity.

Thus, it is possible to argue that direct contact with the area of serious games stimulates learning and critical thinking, making serious games at the communicational and social inclusion level relevant, even though there is no panoply of choice for people with disabilities.

Not too long ago, communication between the community of deaf and blind people was almost an unreachable challenge, especially when there were not enough technological advances to create easy contact between them. Nowadays, there are several tools such as motion sensors, text-to-speech, and speech-to-text that, being well implemented and tested with the intended audience, can enhance this communication. However, sign language differs from country to country, making the development of complex software for such a small niche market unattractive due to the high operational cost.

For this reason, the aim of the following article is to present the development of a multiplayer serious games for deaf and blind people, focused on teaching and learning Morse code.

## 2 Games, Serious Games and Learning

The game concept can be classified as an activity where there are time limits, a restricted area for this practice, rules that serve to keep the rights and responsibilities of the participants undamaged, as well as providing a competitive environment different from the usual [4]. According to Avedon and Sutton-Smith, it is a voluntary exercise where there is a competition between powers confined by a set of rules to produce an unbalanced result [5].

---

<sup>1</sup> ACE - Assisted Communication for Education

From Salen and Zimmerman's [6] point of view, the game is a system in which players are involved in an artificial conflict, defined by rules, which determines a quantifiable result. However, a serious game is a mental challenge, where the player usually plays against a computer within a set of rules, that uses entertainment as the aim to enhance education, health, public policies, and strategic communication goals [7]. For this project, the aim is to create a multiplayer game, different from the common serious games that usually involves a man versus a machine, developing a level of learning defined by the capacities of the intervenient.

According to Michael Zyda, the main objective of a serious game is to create practical simulations of everyday life, offering training for professionals, critical situations in companies and/or institutions, as well as raising awareness among children, young people, and adults on matters such as education. They also consist of a combination of digital games with entities, resulting in a theoretical-practical educational teaching. Learning is the keyword and includes educative games, business games, simulation games, among others, covering a broad set of contents, contexts, and audiences [8].

Associated to serious games, the concept of Inclusive Design [9] can be described as an approach to include the maximum of possible people, particularly the population with special needs and older people. Despite having similar points of view to Universal Design, where "one size fits all", the Inclusive Design aims to include users with more specific needs. This project, however, focuses on deaf and blind communities, hence the interfaces designed are in line with the specificities foreseen and intended by the target audience.

To promote learning through a serious game among the deaf and blind communities it is necessary to understand which method is better to develop a means of interaction. The taxonomy developed by Bloom, can be applied to various areas and not only to knowledge [10]. This taxonomy has been applied to areas such as learning or specific objectives of knowledge, psychomotor or individual skill-based goals, and value or emotion-based goals [10].

In a reviewed version of Bloom's taxonomy [11], there are six levels for the basic domain of knowledge in the cognitive model (Fig.1): remember, understand, apply, analyse, evaluate, and create.

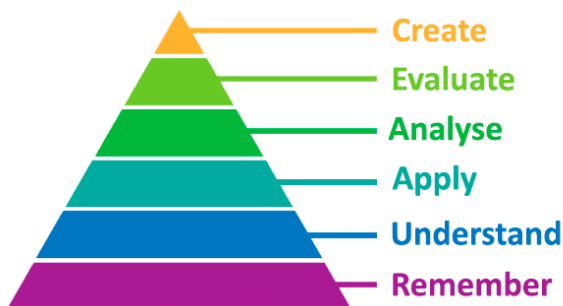

**Figure 1.** Bloom's taxonomy adapted from Bloom et al. [12]

These levels increase in complexity as the level of abstraction also increases. The first level, *remember*, allows us to ascertain whether the target audience has acquired some basic knowledge by asking questions about some of the concepts presented. Once the student shows that his or her knowledge is valid, it is possible to move on to the next point in the taxonomy.

In the next level, *understand*, the target audience can explain the acquired knowledge through their own words. The type of questions to test that knowledge must be clear so it can be possible to conclude that the target audience understood the content instead of memorizing it. The third level, *apply*, requires the previous matters to be applied. Through a learning-based serious game, it is possible to put that knowledge in action. For the time being, the area of serious games is an interesting theme which has been growing in importance in recent years.

The fourth level, concerning the analysis of a concept, enables the target audience to communicate properly and to explore other ways of learning in a way that such knowledge can be induced to other users, enabling learners to take control over their development process. Thus, the guidance received has a greater significance and, above all, a greater impact [13]. The following level, *evaluate*, states if the student can tutor other students who are at lower levels. They can express opinions about information, ideas or the quality of the work presented to them.

Finally, *create*, means that the student is capable of exercise the responsibility to innovate or plan ways to explain the information obtained along its learning process. The Morseline (game title for the developed multiplayer game) uses partially Bloom's taxonomy as methodology in the learning stages during its gameplay.

To solve the proposed problem, it was necessary to conceptualize a high-level architecture able to unravel the communication between the different components inherent to a practical solution.

### 3 Solution architecture

As such, the architecture implemented for the developing serious games can be accessed in Fig. 2, through a representation of the system/framework components diagram that will be further described. The architecture proposes three main components: (1) component referring to the game interface, in which the user can access the serious game either through a PC or mobile device with Android system; (2) the component that relates the four main implementations that are constantly interconnected with the business logic of the serious game; and (3) component related to the game server that includes the multiplayer implementation through sockets and a REST API together with a database in order to make the serious game endure.

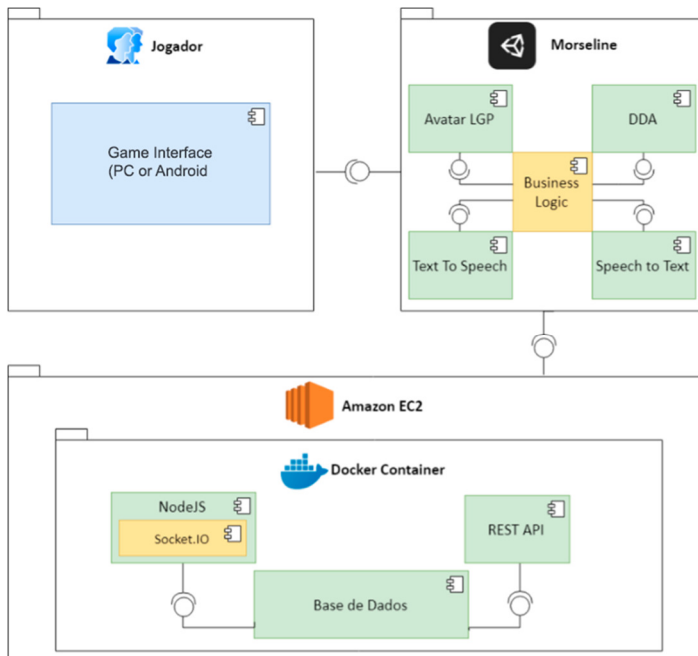

**Figure 2.** Diagram of components representative of the system/framework

### 3.1 Implementation view

The “player” component shows the starting point for any action between the game and its parts. The user will be able to access the game through a computer, preferably one equipped with Windows operative system, or through a mobile device with an Android system.

Next we have the component related with the game developed, Morseline, that introduces four subcomponents related with the used implementations for players accessibility, and the Dynamic Difficulty Adjustment (DDA) component, related to the difficulty presented to players. The fifth subcomponent, business logic, is composed of scripts in C# (programming language) developed in Unity (game engine) to manipulate the actions and data that make up the game.

About the implementation of the DDA, note that this allows to adjust the difficulty presented to the player, considering the user skills as the game evolve. Thus, the player won't be bored if the game becomes easier, nor anxious if the complexity of the game becomes too high. One of the indicators to assess the difficulty of the game is the succession of correct answers provided by two or more players. Considering that this multiplayer serious game works with an online component, the difficulty is balanced between the players, making it harder to reach an impractical difficulty. By adapting the difficulty, it is possible to control the progression margin and thus offer an interesting challenge to the player so that the user develops his skills at his own pace.

Every player starts with 1000 points, a mediated value that allows to match players with greater aptitude, while players who have some difficulty play with others of their learning level.

This assessment is done through the results obtained in the games. During the search of an opponent in game modes, the maximum difference between two players can never be over 200 points, to prevent disparities in their skill level. This classification system was designed based on a worldwide system known as *rating ELO*, that is used on chess and created by Arpad Elo. The following figure (Fig. 3) presents the evolution of a player in the game using the DDA.

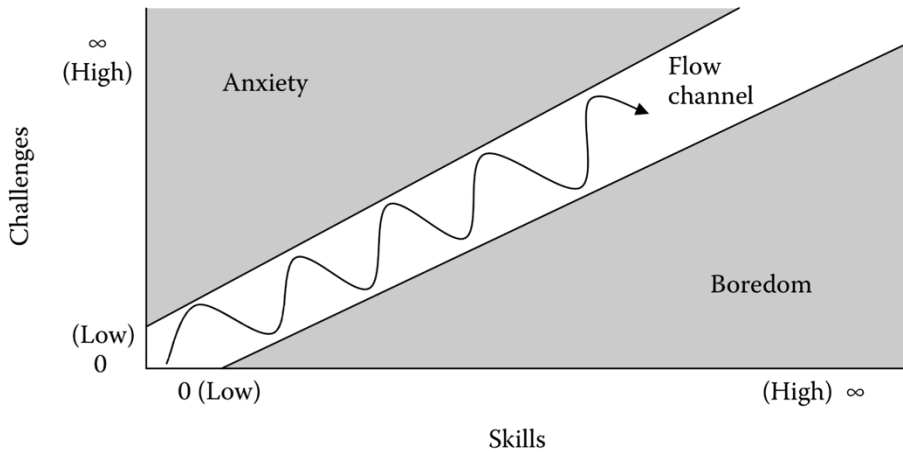

**Figure 3.** Evolution of a player over time playing the game [14]

The book “The Art of Game Design” by Schell [14] mentions that the cycle of 'tension and release' appears several times in design. It seems to be something inherent to human satisfaction. Too much tension wears the player out. Too much relaxation tends to bore the player. So, when we vary between the two, we enjoy both relaxation and excitement, and this oscillation provides the pleasure of multiplicity as well as the pleasure of anticipation [14].

As for the subcomponents of text-to-speech and speech-to-text, these allow the implementation and use of Portuguese language using the synthesized voice of Cortana in case the game runs on Windows. On Android mobile device, the text-to-speech engine also allows for that in case the device can provide the European Portuguese.

Another subcomponent used is the Avatar of Portuguese Sign Language, an avatar developed by GILT (Games, Interaction and Learning Technologies), that aims to support deaf users and those who understand Portuguese Sign Language. The user can click or select the text presented in the game to obtain a real-time translation operated by this avatar.

The server component is divided into two main components, a virtual machine (Amazon EC2) hosted on Amazon's cloud platform, called Amazon Web Services, and the Docker container which provides an image-based deployment model. It makes it easy to share an application or set of services, including all their dependencies across multiple environments.

Docker also automates the deployment of the application (or set of processes that constitute an application) within the container environment [15]. In this project two images are deployed, one with NodeJS that not only enables the integration of the online component of the game through socket communication, but also the creation of a REST API to obtain data regarding the ratings on the game server. The second image that makes up the Docker container is the database, which through NodeJS will receive the data that must be endured between the players and the server.

To define the essential functional requirements to the serious game, 10 essential requirements were determined for the development of the game, in particular the focus on the player. These functional requirements are actions or tasks accessible to the players: (1) The serious game should allow to choose the accessibility need by the player; (2) The player should have a means to authenticate/associate the device; (3) The player can enter any queue for a particular game mode; (4) The player can learn Morse code before testing the knowledge against an opponent; (5) The player can check several times the possible answers until giving a final answer; (6) The player has unlimited response time; (7) The player has dynamic adjustment of the game difficulty; (8) The player should have access to his current score; (9) The player has access to a chat room; and (10) The player can leave the game.

Regarding the database used in this serious game, its purpose is the preservation of data, namely those concerning the player. Some preferences such as the chosen accessibility are stored in the memory of the device that the user uses during the gameplay of this serious game. Using PlayerPrefs, a class that belongs natively to Unity, it is possible to store this data in memory.

### 3.2 Game rules and mechanics

The Morse code is a system represent by letters, numerals and punctuation using sound signals. These signals can be short or long, and they translate into a visual scheme of dots (short signals) and dashes (long signals). Afterwards, in a first phase it was necessary to divide the digits into different degrees of difficulty (Table 1). To simplify it for the players, the punctuation was removed from the learning process.

**Table 1.** Morse code associated to each difficulty

<b>Difficulty Levels</b>	<b>Morse Code characters</b>
Easy	"T", "E", "M", "N", "A", "I", "H", "S"
Medium	"G", "K", "D", "W", "R", "0", "6", "U", "O"
Hard	"Q", "Z", "Y", "C", "X", "B", "J", "P", "L"
Very Hard	"F", "V", "1", "2", "3", "4", "5", "7", "8", "9"

The levels of difficulty were distributed from the letters and numbers with the least number of sounds to memorize to the most complex that contemplated five signals. However, some of the letters or numbers such as "H" were selected for the lowest difficulty level because the short sound is repeated four times, which allows this letter to be memorised more easily.

During the game, whichever game mode is chosen, the player will have four checkpoints that the user must pass. At each one, the player will hear a telegraph emitting the sound of a signal in Morse code. The player will have two options at each checkpoint, one being the correct answer.

## 4 Implementation of the Serious Game

Since blind and deaf people have different needs, at the beginning of the game a short introduction through sound is given about the basic mechanics. This way, at the beginning of the game it is possible for players to choose which type of accessibility they need, with hearing or visual support (Fig. 4). Based on their choice, the game interfaces are adapted.

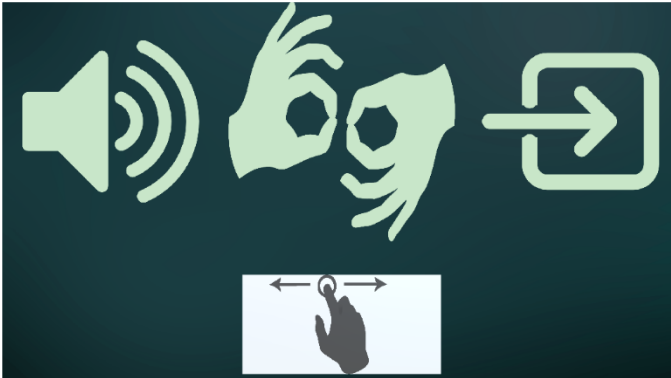

**Figure 4.** Choice of hearing support (left), sign (centre), or no additional support (right)

### 4.1 Development of the Initial Interface

The start menu of the game (Fig. 5) is the first screen presented to the player that allows him to interact with the implemented functionalities, from making changes relevant to the player type of accessibility (e.g., text to speech speed, sign language avatar size), enjoy interaction with other active players on the server through conversations, learn more about the history of Morse code, learn the Morse code corresponding to each alphanumeric value or test his knowledge by playing multiplayer in three available game modes. All information on the screens is available with audio description and Portuguese Sign Language.





**Figure 5.** Start menu with sign language accessibility

A section was developed for the player to have a first contact with Morse code. In this section, the player can go through all the alphanumeric digits that constitute the Morse code. Although there is a correlation with other digits such as comma or question mark, at this stage of the project it was preferable to forget punctuation due to the added difficulty degree given for the player to memorize that could vary between the short beep or long beep. In total there are 36 digits with a corresponding Morse code, being them 21 consonants, 5 vowels and 10 numbers (Fig. 6).

In the case of using voice accessibility, as the player scrolls through the digits, he will hear the sound of the letter he is exploring, possible after pressing the space bar or, if he is on an Android device, through double tapping to access the correspondence to the letter selected. By using Portuguese Sign Language as a means of accessibility, you will have information about the letter or numeral you want to know in Morse code. If they do not choose any accessibility, the Morse code will be presented on sound and visual form corresponding to the alphanumeric value chosen. If the player, however, decides to remove the sound from the game, he will not be under any disadvantage during learning.

If the player decides to be self-taught, he has an option to learn Morse code without being dependent of a second player. Here is given the first step of Bloom's cognitive model, where memorizing is done by the player associating the Morse code sounds to the letter or number. Making a parallelism with the first step, we check if the target audience were paying attention on the presented content and if they have acquired some knowledge by asking questions while the player explores the digits.

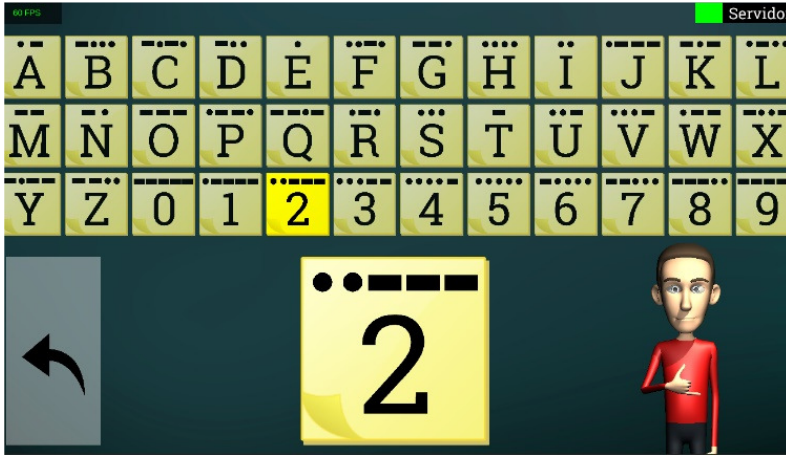

Figure 6. Menu layout of Morse code learning

## 4.2 Development of the Initial Interface

Three game modes were developed: the traditional 1 versus 1, a cooperative mode between two players and a game mode for up to 4 players simultaneously. Using environmental assets, it was possible to organize a scenario where it was possible to implement the objects associated with the game. In what follows, Fig. 7 shows a general view of the scenario used. In red we can see the small portion of the map where the player will navigate, corresponding to the four checkpoints developed for this game. The scalability of the game is high since there is enough room to incorporate other environmental and sound components to create a more pleasant experience. With the purpose of keeping the game functional and with good quality in terms of performance, the resources used in a context outside the use of the computer are the minimum ones since the rendering of 3D objects is high.

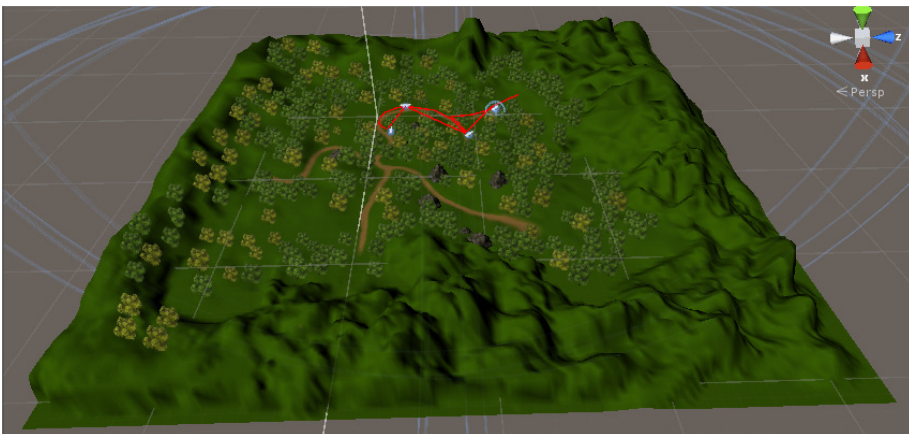
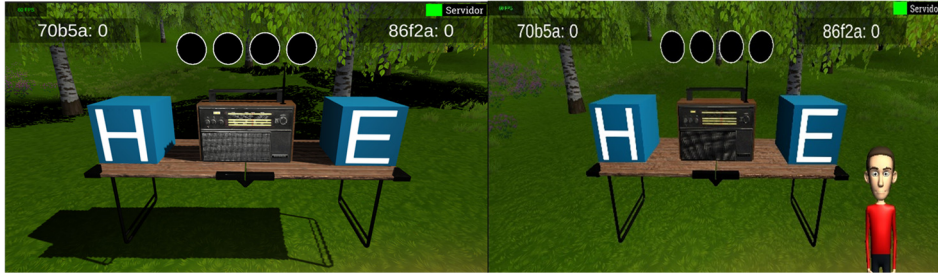

Figure 7. Overview of the game map with the four checkpoints

To incorporate the dynamic difficulty adjustment component in these game modes, four checkpoints were implemented, consisting of a Morse code being emitted by a telegraph and two possible responses, and can be scalable through new checkpoints and levels (Fig.8).



**Figure 8.** Example of a checkpoint through the interface presented to a user without accessibility when using a PC (left) and the interface presented with sign language (right) using an Android device

As proof of concept and since this is a multiplayer game, considering the initial complexity in learning and after feedback obtained with the target audience, it was preferable to implement a short and functional path. In this route, the difficulty will be dynamically adjusted according to the performance of both players since the Morse code presented will be the same. If both players reach the first checkpoint, when they get to the second checkpoint the difficulty will increase slightly, i.e., adding one alphanumeric value to the Morse code. Although, to be reasonable, if one or both players miss, the difficulty is maintained at the next checkpoint. This way, the more skilled player will receive a victory score at the end, allowing them to be paired up with more skilled players in the next game. When the passage through all the telegraphs present is over, the server calculates the new score acquired by the players, displaying the result obtained in the game and the new points in the league table. This calculation is based on the ELO rating system, as mentioned above.

The team game mode is similar to the previously mentioned game modes, where initially a short tutorial is presented with audio description, sign language or text according to the active accessibility needs of the player. The difference that gets the player's attention is that the communication between the two players is active, i.e., both can communicate with each other in the way that is most convenient. If the player is blind and assuming he chooses the voice accessibility mode, using the defined controls, he will be able to communicate with the other player by voice. In turn, the other player receives the message in text, although how it is played depends also on their accessibility choice. That said, both players can share their opinion on the correct choice for the Morse code broadcast via telegraph.

## 5 Evaluation Methodology

In order to verify if the serious game with Morse code and sign language contributed for the improvement of social inclusion and access to education of deaf and blind people, the game was evaluated with a total of 14 respondents.

To evaluate the final solution, the following dimensions were defined to assess the quality of the serious game:

- Technical - In the technical aspect of the game it is possible to conclude if the functionalities and accessibilities provided meet the player's requests;
- Ergonomics - On the ergonomics dimension, it is intended to obtain comments about the player's interaction with the serious game on the platform intended by the player. In this case, the factors to be evaluated are usability, playability and socio-cultural;
- Pedagogical - The pedagogical magnitude allows to access if the serious game had a positive effect on learning, in this case, through the Morse code theme. The factors to be assessed are learning and critical thinking.

### 5.1 Quantitative Evaluation Framework

To validate the quality and performance of the developed serious game, an analysis using the Quantitative Evaluation Framework (QEF) was performed.

The QEF is a generic tool that allows evaluating any platform at any stage of its development [16]. It usually presents three dimensions, and each of these dimensions presents a set of factors, each of which is formed by a group of requirements [17].

In accordance with the requirements of this project, it is possible to define the QEF in three dimensions: pedagogical, ergonomic, and technical. These dimensions allow assessing the objectives intended with this project.

Regarding the pedagogical dimension, the two factors that are intended to be assessed are learning and the accessibility provided for that purpose. The types of requirements assessed refer to Bloom's taxonomy and the theme of Morse code.

In the ergonomic dimension three factors are assessed: usability, playability and sociocultural. Regarding usability, the requirements assessed include the interaction between the player and the serious game, as well as factors external to the player, but relevant to usability, such as server performance and the platforms where the game can be executed.

Finally, the technical dimension allows assessing the functionalities implemented in the serious game and if the types of accessibility implemented are used conveniently so that the target audience feels that it is not invasive, but an added value in the game.

In total there were 57 requirements defined in the QEF (Table 2), in which the requirements were evaluated using the use of the game by the target audience. To this end, a survey was developed to address these factors. In the general contingent of the QEF and using the feedback obtained during the experimentation phases of the project prototype with the target audience, the QEF allowed obtaining a compliance rate of 88%, which is an interesting result given the target audience with accessibility needs implemented to provide them with a pleasant experience. Overall, the users were pleased with the experience and recommended the serious game for Morse code learning purposes.

**Table 2.** Quantitative Evaluation Framework (QEF) for Morseline

Dimensions	Qi	Pij (Weight of factor j in Dim i) [0,1]	Factors	prjk (Weight of requirement k in Factor j) {2, 4, 6, 8, Requirements	pck (% fulfillment of requirement k) [0.100]	
Pedagogical	87,07	0,55	Learning	10	The game promotes an incremental educational line	75
				8	The game rewards players who best identify the Morse code presented	100
				10	At each checkpoint, players receive a comment whether the answer was correct or not	75
				10	The learning context follows the guidelines presented in Bloom's taxonomy	100
				10	The learning context for Morse code is appropriate	75
				10	The game enables recognition of patterns interlinked with Morse code	100
	79,17	0,45	Critical thinking	10	Game promotes self-directed learning	100
				8	The game allows for the collection of information about Morse code before the player enters a game	100
				10	Through response possibilities, the player can make the most correct decision	75
				10	Through audio about Morse code and the corresponding character, the player can make a mental association	75
Ergonomic	82,07	0,45	Usability	10	The navigation interface is intuitive	100
				10	In-game instructions are clear, precise and concise	50
				10	The user can easily start and exit the game	75
				10	Navigation between menus is consistent	75
				10	The game content contains no grammatical or syntactical errors	100
				10	Game is cross-platform	75
				10	Visual and auditory feedback is provided on player actions	75
				10	Server performance is acceptable	100
				6	Game takes advantage of native platform features	75
				6	Game can be updated without affecting current settings on the device	100
81,55	0,45	Plav	10	Appropriate supports for accessibility needs enhance gameplay	100	

Dimensions	$Q_i$	$P_{ij}$ (Weight of factor $j$ in Dim $i$ ) [0,1]	Factors	$p_{rjk}$ (Weight of requirement $k$ in Factor $j$ ) {2, 4, 6, 8, Requirements	$p_{ck}$ (% fulfillment of requirement $k$ ) [0,100]					
				8	The game is challenging	100				
				10	Morse code is understandable	100				
				10	The main objective of the game is made clear at the start of the game	75				
				10	The difficulty is adapted according to the players' responses	75				
				10	The player pairing system is fair	75				
				4	The history of Morse code is inserted to enrich the knowledge of the subject	100				
				8	The game provides hints during gameplay	0				
				8	The game features several checkpoints available at each game scenario	100				
				6	The scores obtained reflect the level difference between the players	100				
				78,57	0,1	Sociocultural	6	Game is available in several languages	50	
							8	Game does not contain offensive content or violence that may offend any community	100	
				Technical	88,39	0,58	Functionality	10	User chooses the type of accessibility	100
								10	User is able to create an account	0
								10	User has account associated with device	100
8	User enters any game mode queue	100								
8	User logs out of game mode queue	100								
10	User logs into game after server has found the required players	100								
8	User chooses which character of the Morse code he/she wants to learn	100								
10	User can see or hear the Morse code	100								
6	User can make changes related to his accessibility type	100								
6	User can repeat Morse code within the game	100								
10	User can repeat the possible answers to decipher Morse code	100								
2	User is given a rating in the game	100								
6	the user can check the global scores	50								
8	User can leave the game	100								

Dimensions	Qi	Pij (Weight of factor j in Dim i) [0,1]	Factors	pr,jk (Weight of requirement k in Factor j) {2, 4, 6, 8, Requirements	pck (% fulfilment of requirement k) [0,100]	
			Accessibility	10	The synthetic voice communicates conveniently with the player	100
				10	Instructions given by the synthetic voice were clear	75
				10	The speed of the synthetic voice is appropriate	75
				10	The audio or visual cues during menu navigation are adequate	75
				10	The audio is balanced	100
85	0,42			10	Sound should not be intrusive to navigation and gameplay	75
				10	Sign language avatar communicates appropriately with the player	75
				10	Instructions given by the avatar are clear	75
				10	Produced gesture speeds are appropriate	100
				10	Avatar should not be intrusive to the navigation and playability of the game	100

### 5.2 Testing and Assessment

When the players were asked whether they had gaming habits in the last year, 85,51% (N=12) answered yes and 14,29% (N=2) answered no. When asked about their favourite platform to play in (PC or smartphone), 64,29% (N=9) chose PC and 35,71% (N=5) chose smartphone.

Afterwards, the first component of the questionnaire related to the pedagogical dimension and the questions focused on the theme Morse code, in relation to its learning or application in a game. This component was composed by 5 questions that included five choice options. A Likert five points standard scale was used: totally agree (5), partially agree (4), neither agree nor disagree or neutral (3), partially disagree (2) and totally disagree (1). In the second part of the questionnaire, the questions focused on the ergonomics dimension, placing questions about usability and playability of the serious game. In this component of the questionnaire there were 6 questions. Some of the answers given also served as support to the technical dimension of QEF.

Finally, the placed questions focused on the technical dimension of the game, its functionalities and online component. The questionnaire was made available online through the Google Forms platform, in the format of open-ended questions to understand if the respondents were regular gamers and what type of games they were interested in. In the end of every survey, a comment was asked to the users their suggestion about new functionalities and improvements that they would like to see implemented.

In a first phase of testing, that lasted two days, there were 5 people in the first group that tested the solution, where there were two blind female people from birth, two blind male people and a young male with low vision. ACAPO was very important to carry out these tests because it offered very proper conditions and enough time to accurately test the game. Still during the first phase of testing, which mainly contemplated the gameplay limited to two checkpoints instead of the four presented in the final solution and which served mainly to get feedback from the development, the game was tested with random users. Most of them did not have any kind of hearing or visual impairment, but they preferred to try the game with hearing support or without any kind of accessibility. Even though the target audience are the blind and deaf communities, these respondents still tested the game, and they are still able to play this serious game as long as they do not choose the hearing or visual support option at the beginning of the game. In this group, there was one female and four male players.

In the last phase of tests, ACAPO again offered the chance for assessment, in which some of the respondents also participated in the first phase of tests. As such, it was possible to assess if the development was in accordance with the comments received in the first phase.

## 6 Results

The response rate was 100%, meaning that all users that tested the game replied to the final questionnaire. It is important to note that the population sample tested the game on both platforms, and the answers are based on the gameplay experience on both devices (PC & Android). In this results analysis it is intended to verify if in fact the tested hypothesis is valid or null.

In the three dimensions analysed, the vast majority of respondents gave a favourable answer, predominantly marking options 4 and 5, based on the Likert scale described above. The ergonomic dimension was the most appreciated by respondents, with the average response corresponding to 4.81. It is possible to state that, given that this dimension aims to meet the target audience's accessibility needs, respondents usually evaluated the points referring to the type of accessibility chosen by them with the maximum score.

### 6.1 Pedagogical Dimension analysis

The pedagogical dimension was supported by the answers given to this component of the questionnaire to fulfil the QEF. This dimension ended with a compliance rate of 83.38%.

The fact that all respondents agreed, even if in some cases partially, makes it possible to state that the objective of the serious game to promote education in the target audience already defined was fulfilled. The respondents in their great part had knowledge about Morse code but did not know how to apply it. Respondents who during the gameplay of the serious game chose the hearing support offered a lot of feedback regarding information that could be placed to enhance it, namely in the synthetic voice lines and insertion of new didactic content



with the use of Morse code. Of the three groups of respondents, they were the only ones in which all totally agreed.

In order to validate the tested hypothesis, the result obtained in this question allows the hypothesis to be accepted. Together with the multiplatform implementation of this serious game, respondents develop learning skills and enhance their digital literacy.

## 6.2 Ergonomic Dimension analysis

The ergonomic dimension was also supported by the answers from this component in order to fulfil the QEF. This dimension ended up with a compliance rate of 82.23%, which despite being the one that fulfilled the least requirements in its entirety, was also the most complex to assess with the QEF since it considered the accessibility components in gameplay for blind and deaf users.

During the planning phase, there was a special consideration to never reveal what type of accessibility the opponent or teammate had active. This result was corroborated with the opinion of the respondents, where 92,86% (N=13) chose "totally agree" and 7,14% (N=1) "partially agree" about omitting the type of accessibility used by the participants. In this case, being a multiplayer serious game, whose aim was to promote learning to its users, there is no interest in knowing whether the players they face are blind or deaf for example, except for statistical purposes. Even during the team game mode or while using the chat room, users communicate in the most convenient way for them, and the message sent is handled according to the accessibility chosen by the users receiving it. Consequently, the vast majority of users gave the maximum score during this question.

Regarding equity, only one respondent did not agree that the game promoted it. A possible justification may be that this respondent is a user who has not tested the accessibility component for the blind or deaf. In other words, not being aware how all the implemented interfaces worked and what the intended needs were for users from these communities, he chose to give a score of three (Indifferent) on the Likert scale.

## 6.3 Technical Dimension analysis

The technical dimension, which encompassed the game functionalities, relied on the answers given by the respondents in order to complete the QEF. This dimension ended with a compliance rate of 86.98%.

During the development of the game, one of the plans was to allow users to easily access the preferred accessibility choice. As previously stated and demonstrated, the controls are simple for any type of user and the ways to navigate the game are well explained. That's why in the question "Can you easily choose the type of accessibility?" the respondents were unanimous in answering "I totally agree". The fact that the users were unanimous was important to validate the development about accessibility needs to promote the best possible experience while using the game.

## 7 Conclusion

At the core of this work was the almost non-existence of games that were accessible to the blind and deaf communities at the same time. Even though the population with these specific accessibility needs are a minority, they should not be forgotten. At a time when technological advances are greater than ever, the remoteness of technologies created for people with disabilities is increasing.

In light of this situation, the system/framework was developed using a practical example that offers a learning theme that sets almost all its users at the same level, regardless of whether they have some kind of disability or not, due to the fact that few people have practical knowledge of how Morse code works, even if having a brief idea of what it might be.

As such, during the research phase, information was collected regarding methods of applying accessibility tools, as well as design architectures that follow appropriate guidelines for specific accessibility cases along with models that promote learning. Also, during this phase it was not possible to find any game, irrespective of whether it was a serious game, that was prepared to provide means of accessibility to blind and deaf people simultaneously.

During the design and development phase of the solution, good engineering practices were adopted from project planning to the use of a project version control system using GitLab and the use of QEF to assess the quality and intended evolution of the final solution. In the end, the compliance rate was 88%, leaving room for improvement in order to make the developed project a useful tool for learning Morse code or even for other education-related topics.

The solution was tested, improved, and validated with the support of the Association of the Blind and Visually Impaired of Portugal (ACAPO) and with the help of randomly chosen users for testing. By the end, 14 survey responses were collected. University students tested the serious game without any active accessibility, which also allowed to include a larger amount of population that can use the game for learning purposes and at the same time for entertainment while trying to get the highest score on the server.

As already mentioned, the initially proposed objectives which were to improve social inclusion and access to educational themes to promote learning for blind and deaf people were achieved after the hypothesis put forward during the experimentation and evaluation phase was validated. The aspects related to accessibility, namely through a voice assistant (text-to-speech), the use of the capabilities of the devices in which the serious game was executed to allow the conversion from voice to text and a Portuguese sign language avatar were only implemented with due success given the improvements made during the development of the project by means of essential comments that were provided during the testing phase of the solution.

Considering those comments, improvements in the avatar would be an important step in supporting people who use Portuguese sign language, as it can sometimes disrupt the context of some of the words it translates or else translate letter by letter instead of translating a word in its entirety. The use of machine learning to improve speech to text would be an

important advance, because currently some of the words identified using the library provided by Unity are not correctly detected.

In conclusion, the inclusive game on screen allowed the team to prove that the use of accessibility guidelines during software development, which in the case of this work was a serious multiplayer game, permits the inclusion of communities previously excluded. To do so, it is enough to carry out a commitment with these communities during development, as well as to realize that a small gesture can change their lives.

## References

- [1] WHO - World Health Organization, *World report on vision*, Geneva, Switzerland: World Health Organization, 2019.
- [2] WHO - World Health Organization, “Deafness and hearing loss,” WHO, 2019. <https://www.who.int/news-room/fact-sheets/detail/deafness-and-hearing-loss> (accessed April 10, 2021).
- [3] CM-SJM, “Serviço de vídeo-intérprete para atendimento ao munícipe através de Língua Gestual,” 2018, Câmara Municipal de São João da Madeira. <http://www.cm-sjm.pt/pt/noticias/7-municipio/27-servico-de-video-interprete-para-atendimento-ao-municipe-atraves-de-lingua-gestual> (accessed June 11, 2019).
- [4] J.L. Gillin, and J. Huizinga, “*Homo ludens*: a study of the play-element in culture,” *American Sociological Review*, vol.16, no. 2, 274–274, 1951, doi:10.2307/2087716.
- [5] E.M. Avedon and B. Sutton-Smith, “The study of games,” New York, J. Wiley, 1971.
- [6] E. Salen, and E. Zimmerman, “Rules of Play: Game Design Fundamentals,” MIT Press, 2004.
- [7] M. Zyda, “From visual simulation to virtual reality to games,” *Computer*, vol. 38, no. 9, pp.25–32, doi:10.1109/MC.2005.297.
- [8] B.H. Sørensen and B. Meyer, “Serious games in language learning and teaching: a theoretical perspective,” in *Proceedings of the 2007 Digital Games Research Association Conference*, Tokyo, pp. 559-566, 2007.
- [9] U. Persad, P. Langdon, and P. Clarkson, “A framework for analytical inclusive design evaluation,” in *Proceedings of ICED 2007, the 16th International Conference on Engineering Design*, Paris, 2007.
- [10] S. Tabrizi, and G. Rideout, “Active learning: using Bloom’s taxonomy to support critical pedagogy,” *International Journal for Cross-Disciplinary Subjects in Education*, vol. 8, n.3, pp. 3202-3209, doi:10.20533/ijcdse.2042.6364.2017.0429.

- [11] D.R. Krathwohl, "A Revision of Bloom's Taxonomy: An Overview. Theory Into Practice," vol.41, no. 4, pp. 212–218, 2002, doi:10.1207/s15430421tip4104\_2.
- [12] B. Bloom, M. Englehart, E. Furst, W. Hill, and D. Krathwohl, "Taxonomy of educational objectives: The classification of educational goals," *Handbook I: Cognitive domain*, New York, Toronto: Longmans, Green, 1956.
- [13] Growth Engineering, "Bloom's Taxonomy and Online Learning," eLearning Learning, 2019. <http://www.elearninglearning.com/bloom/gamification/taxonomy/?open-article-id=5776609&article-title=bloom-s-taxonomy-and-online-learning&blog-domain=growthengineering.co.uk&blog-title=growth-engineering> (accessed June 5, 2019).
- [14] J. Schell, "The art of game design: a book of lenses," CRC Press, Taylor & Francis Group, 2008.
- [15] RedHat, "What is Docker?" 2019. <https://www.redhat.com/en/topics/containers/what-is-docker> (accessed June 12, 2019).
- [16] P. Escudeiro and J. Bidarra, "Qualitative evaluation framework," *RISTI-Revista Ibérica de Sistemas e Tecnologias de Informação*, vol. 0, no. 1, pp.16-27, 2008.
- [17] C.V. Carvalho, P. Escudeiro and A. Coelho, "*Serious games, interaction and simulation: 6th International Conference, SGAMES 2016, Porto, Portugal, June 16-17, 2016, Revised selected papers*," vol. 176, Springer International Publishing, 2016.

# Inclusive Digital Learning through Serious Games: a Clipping for Inclusion

Paula Escudeiro<sup>1</sup>, Dirceu Esdras<sup>2</sup>, Bruno Galasso<sup>2</sup>, Nuno Neto<sup>1</sup>, Flávio Costa<sup>1</sup>

<sup>1</sup> Games, Interaction and Learning Technologies R&D Center, Instituto Superior de Engenharia do Porto, Rua Dr. António Bernardino de Almeida, 431, 4249-015 Porto, Portugal

{pmo, 1160643}@isep.ipp.pt, nunoarneto@gmail.com,

<sup>2</sup> Instituto Nacional de Educação de Surdos, Rua das Laranjeiras, 232, 22240-003 Rio de Janeiro, Brasil

{galasso.bruno, diresdras}@gmail.com

**Abstract.** *Serious games have a great potential to help the population develop new skills or improve previously existing ones. However, part of the population does not have the means to play these games. Therefore, this article aims to discuss the use of serious games for deaf and blind people, as well as show the development of serious games inclusive, presenting specific concepts for each target audience. We used the cognitive model proposed by Mayer (2005) to describe some fundamental principles behind multimedia learning, defined from his theory and based on the evidences that are essential for the elaboration of serious games for deaf and blind people. We hope that the games developed, and guidelines provided will help game designers and game developers to achieve successful implementation in inclusive games.*

**Keywords.** Serious games, inclusive games, accessibility, design model for inclusive games, development methodologies for inclusive games, assistive technology

## 1 Introduction

The popularity of digital games has skyrocketed in a last couple of decades – the Entertainment Software Association reports that 60% of Americans play digital games daily and 70% of parents believe video games have a positive influence on their children’s lives [1].

Game as a concept can be labeled as an activity where components such as temporal limitations, an area defined to play or rules to keep participants rights and duties intact, while providing a competitive environment different than usual [2]. According to Avedon and Sutton-Smith [3], “games are an exercise of voluntary control systems, in which there is a contest between powers, confined by rules in order to produce a disequilibrium outcome”.

A game represents a subjective and oversimplified emotional reality. It is not objectively an exact representation of reality, in fact is mainly represented enough to fulfil a player expectation. A player’s fantasy is the key to make a game psychologically real [4]. When it comes to interaction, which not only is associated with game representation, there’s ways to make it dynamic and to change it accordingly through interactions. A player can’t distort reality by making simple choices and see the unfolding of those events. There can be physical threats towards the player, however, a game allows the player to experience psychological conflicts without having any physical alteration, resulting in an action / consequence dissonance. Crawford [4] refers that even though it may not threaten the player in real life, it can have a negative impact in the game by missing a reward for instance.

When it comes to serious games, they provide a mental challenge in which the player has a set of rules, while having an entertainment component to help improve education, health, politics and strategic goals of communication [5]. Michael Zyda [5] pointed that the primary objective is to create daily simulations to offer training for professionals, enterprise critical situations or raise awareness in a diverse age bracket to topics such as education. Serious games combine digital games with entities to fulfil a theoretical practical education. Learning is the guiding force and includes educational games, business games, simulation games, among others, and they cross a whole range of topics, contexts and target groups [6].

Serious games have a great potential to help the population develop new skills or improve previously existing ones. However, part of the population does not have the means to play these games. Some may be unable to experience all the elements that are present in these games. Besides, larger companies usually do not develop games for these audiences considering their reduced size [7]. That is why inclusive games were created, “games proactively designed to optimally fit and adapt to individual gamer characteristics and to be concurrently played among people with diverse abilities, without requiring particular adjustments or modifications” [8].

This article aims to discuss the use of serious games for deaf and blind people, as well as show the development of serious games inclusive, presenting specific concepts for each target audience.

## 2 Design Model of Inclusive Games

During the process of designing inclusive games, Mayer’s principles on Multimedia Learning [9] were applied as a form of quality validation. All the examples provided in this section follow these principles, alongside a quality evaluation model.

### 2.1 Game Development Methodologies for Deaf People

Considering the way in which deaf people organize thought and language, as well as the potential of the students’ development in the visual field, the project of serious games needs to be designed through a visual-spatial perspective. Therefore, we develop serious games following the "deaf way", that is, "a way of formulating ideas based on imagery representations capable of being translated in the Sign Language itself and in visual aspects" [10].

Such an understanding does not deny the presence of the oral Portuguese language to listeners, who are also part of the audience of the game proposed here. The idea here, as suggested above, is that there are advantages in adopting different languages, Portuguese and Libras. In addition, if the visual-spatial perspective – whether being that through Libras or imagery texts – is essential for deaf people, for the non-deaf it is extremely enriching. Within this context, the use of serious games reveals great potential in the field of educational sciences, because in this modality "thought is mapped by domains of distinct concepts, structured by image schemes" [11].

Currently, there are several research projects exploring multimedia instruction and learning focusing on hearing students; however, studies focusing on deaf students or students with some kind of hearing impairment are rare. When developing serious games for deaf people, we also take into account some principles based on knowledge about how the brain processes information during learning. According to Mayer [12], one of the most important areas of Cognitive Psychology is the understanding of technology as a tool to promote efficient learning. Through the main theories of cognition, concrete and effective learning occurs following a few steps or stages. In Fig. 1, we provide how information processing occurs according to Mayer’s Cognitive Theory of Multimedia Learning [9], adapted to the perspective of the deaf student.

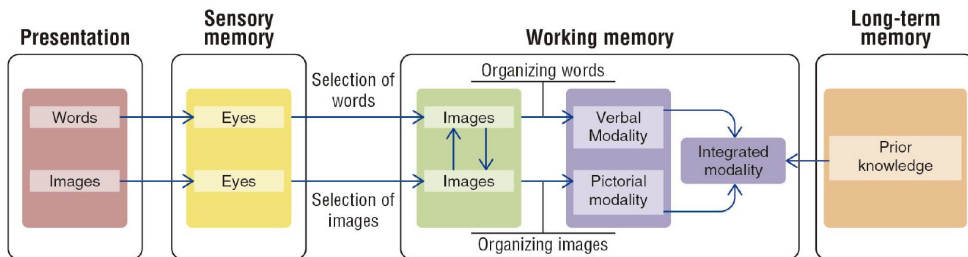

**Figure 1.** Mayer’s [9] information processing model adapted to the perspective of a deaf person

The processing of information starts from the moment the deaf student assimilates images and words from a multimedia presentation, which can be, for example, a game in Sign Language. To capture this presentation, written words and images enter through the eyes of the deaf student and are briefly represented in the sensory memory. Then, in the working memory, the deaf student selects the main words and images and organizes them, categorizing written words in a verbal model, and images in a pictorial model. From this organization an integrated model of information is structured. This integrated model is directly linked to the long-term memory, where the student can activate pre-existing knowledge to be integrated with verbal and pictorial models in the working memory, storing the resulting knowledge in the long-term memory.

### ***2.1.1 Evidence-based principles in serious games for Deaf People***

The cognitive model proposed by Mayer [9] describes some fundamental principles behind multimedia learning, defined from his theory and based on the evidences that are essential for the elaboration of serious games for deaf people:

#### **1. The Multimedia Principle – Words and images are better than words alone**

This principle proposes the combined use of images and words, as it allows the brain to process more information in the working memory [13]. Thus, people learn better with words and images than words alone. In this context, words include written and spoken text, and images include videos, animations, and static graphics. In the education of deaf people, which uses Sign Language as a means of communication, images are essential for understanding academic concepts and, when words are used as well, they help students in the learning process. Due to the visual-gestural characteristic, Sign Language can be presented along with the Portuguese Language, respecting the phrasal structure of each one of these languages, composing two informational processing channels necessary for bilingual education. Similarly, in the serious games developed, we present simultaneity between the presentation of Sign Language and characters. This simultaneity enables deaf students to have a variety of integrated learning styles, broadening their understanding of the content worked. The interaction between image and caption constitutes student-oriented meaning, proposing the textual interpretation of the video and its occurrences.

When we use serious games, we strengthen the compatibility of the readings, establishing singular dynamics in the learning process. The application of the concept in the development of bilingual teaching materials also privileges the hearing since the signaling in Sign Language appears to the students synchronized with the caption and speech in Portuguese Language within the scope of the statement, respecting the syntactic and grammatical structures of each language.



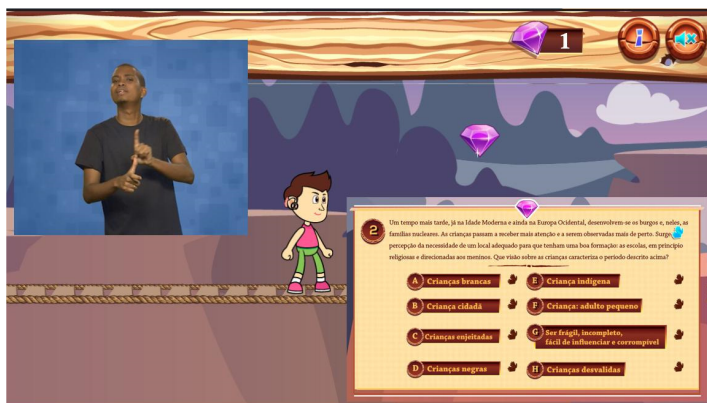

**Figure 2.** Representation of the Multimedia Principle. In this example, a game designed for deaf and hearing-impaired people that consists of multiple-choice questions about Education

## 2. Principle of Spatial Contiguity – Words should appear close to images

This principle includes spatiality as a didactic element to the learning of deaf students. Animation, as a figuration of reality, ratifies the meaning that the text should convey. From the point of view of bilingual education, the use of images close to words composes a mechanism of interface between the two languages (Sign Language/Portuguese Language), as they are part of the linguistic daily life of the deaf and the hearing. Considering the spatiality of Sign Language, written words should be part of the discourse of the deaf presenter, since there is spatial interference between the written register of the Portuguese Language and the movements of the Sign Language. Thus, a truly bilingual learning object is structured with the integration of the two languages into the same statement.

## 3. Segmentation Principle – Contents must be presented by parts

This principle states that people learn best when a multimedia lesson is presented in segments of the user's rhythm instead of a continuous unit. In this context, games are developed at various levels of theoretical depth, so that the student may learn through videos with segmented content.

## 2.2 Serious and Inclusive Games for Blind People

Regarding blind people, the project of serious games needs to be designed with audio-based gameplay. Using this architecture during development allows the user to enjoy the game without the need of a graphical user interface either to interact or understand the application context [14]. Even though its target audience is a niche market, these games are often omitted from general population due to its accessibility standards.

Audio games focus group are blind and visually impaired people because they are developed with audio only in mind. With the growth of text-to-speech software and major improvements related to digital assistant voices such as Cortana, Alexa or Siri, serious games targeted to blind people became a must, because “this type of video game has been growing and its use has spread to several areas of education” [15]. These tools follow two very

important principles in multimedia learning, introduced by Mayer - the Personalization Principle and the Voice Principle. The former states that people learn better when words are in conversational style rather than formal style and the latter promotes learning through hearing a friendly human voice rather than a machine voice [9]. Voice assistants have gradually become more human-like and less formal, trying to make their users feel more comfortable.

These games' narrative is created mainly through sound sources, typically with the help of pre-recorded sounds or text-to-speech limited to the languages implemented by the developers. Moreover, audio games have a tactile or haptic feedback (e.g vibration and/or sound) which can result in an immersive video game atmosphere to blind people [16].

### 2.2.1 An example of a Game for Blind People

*The Field Trip* is a single-player digital game being developed for desktop computers and mobile systems, set in a real-world forest, that develops the player's spatial awareness and orientation, by creating an environment where the player is guided exclusively by sound. It is being developed in Unity3D, using C#. It revolves around the use of 3D audio sources – objects in the world that emit sound depending on the position of the player. This means that if the player is to the right of the audio source, he/she will hear the sound coming from the left, and if the player is to the left of it, the sound will be coming from the right. Moreover, the sound from an audio source only becomes hearable when the player steps into its range, and it becomes louder as the player approaches the center of the source. These audio sources are being developed in accordance to Mayer's multimedia learning principles mentioned in section 2, in order to provide a good player experience.

The game is separated in several layers, each with its own responsibilities, displayed in Fig. 3. The user only interacts with the interface layer, which handles the player's inputs and the sounds that the player hears. This layer then interacts with two layers – the game engine and the business layers. The game engine layer is responsible for executing the game, in this case represented by Unity. The business layer manages the logic behind the game, the rules and mechanics that will be described in this section. Lastly, these two layers communicate with the hardware layer, which is the device that is used to play the game.

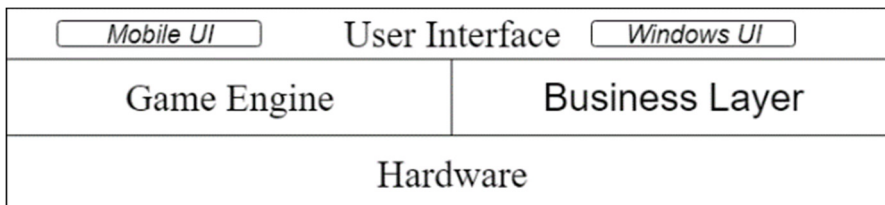

**Figure 3.** *The Field Trip*'s application architecture

As the player traverses through the world and collects items, he/she learns about the forest they are in, as well as the fauna and flora that is being collected. This allows the player to enhance abilities that are useful not only in the context of this game, but also in real-life scenarios where a person must be guided by sound.

In this game the player has been separated from his/her field trip group and must move through the forest in order to find them, going from the starting (spawn) point to the ending area. To do this the player must rely on his/her senses to figure out where he/she is in the map, given audio cues such as the sound that is made when walking through a certain type of terrain or when stepping on tree branches.

To make the movement through the map more challenging, obstacles block the path that the player is trying to take. Elements such as trees or knocked down logs, big rocks or shrubbery that isn't traversable force the player to make slight detours so that he/she can avoid these barriers. By memorizing which the obstacles and terrain in each area, the player can build a mental map of the forest he/she is in, making movement more effective. The second goal of the game is to collect items that are spread out on the map. These range from animals that the player must interact with, to plants that the player can pick up or water from a waterfall that must be collected. When interacting with these items, voice lines give a short description of the item that is picked up.

When the player reaches the end of the level, his/her score is calculated. Each item has an associated score. Items that are harder to get have a higher score than those that are in the natural path the player walks through. At the end of the level, the final score is the sum of all items collected and a previously determined level completion bonus, minus the time the player took to go from the spawn point to the ending area and the number of times the player died.

Lastly, the player would have the objective of surviving threats that would be placed in the environment. These threats are described in Table 1.

**Table 1.** Action table for the *The Field Trip* game

<b>Player Event</b>	<b>Player Response</b>	<b>Effect</b>
Hears bear sound	Moves	Player loses a life and enemy disappears
Hears bear sound	Does not move	Enemy disappears
Hears snake sound or turbulence in water	Does not press the spacebar	Player loses a life and enemy disappears
Hears snake sound or turbulence in water	Presses the spacebar	Enemy disappears
Hears bees sound	Stays in range for longer than 3 seconds	Player loses a life
Hears bees sound	Leaves range before 3 seconds have passed	No effect
Is near item	Presses the spacebar	Player gets points, item disappears, and voice line describes item
Loses a life when no lives left		Player respawns in last checkpoint or start of the level
Reaches the end of the level		Player receives level completion points, advances to next level, and voice lines informs player of points
Walks on terrain		Specific terrain sound is played
Walks into map edge		Informative sound is played

In what follows, Fig. 4 displays some of the elements that exist in the game, such as items (represented as small spheres), enemies (the larger sphere acts as a swarm of bees and the cube represents a bear) and different types of terrain (the larger one serves as grass and the smaller one acts as water).

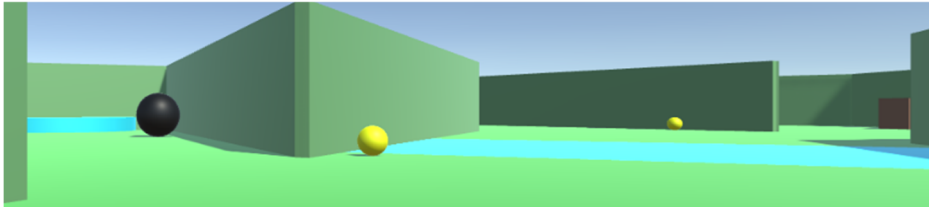

**Figure 4.** Example of the world in *The Field Trip*

### ***2.2.2 An example of a Game for Deaf and Blind People***

*Morseline* is a multiplayer serious game in development for computer and mobile systems in order to help users learn Morse code. To that end same tools are integrated to achieve proper support for both blind and deaf people. To assist blind users, a text-to-speech and speech-to-text functionalities are integrated by using Microsoft's Cortana digital assistant Portuguese voice package, while on Android, Google's own text to speech voice packages. In order to support deaf people, GILT's (Graphics Interaction Learning Technologies) own sign language avatar is used to translate all text in-game to Portuguese Sign Language.

The serious game is not only capable to help on learning Morse code, but also lets users test their knowledge against each other. To this end, three game modes were developed. A one-on-one matchup where both users must finish a course that consists in hearing Morse code being transmitted by three telegraphs, and when in close range they will be presented with two options, one being the correct answer and the other one a decoy. The player who decodes more Morse messages by the end of the match wins. A cooperative mode where both users try to get correct answers in order to achieve success. Using implemented chat system, both players can communicate and share their opinion on what the correct answer is by either using voice or text which is adapted on the other player's end following accessibility needs as defined in Section 2. Last but not least, a four-player mode which consists on the same rules as one-on-one mode, but with the purpose to lay foundations for a massive multiplayer online serious game.

To this end, an action table was planned to understand game flow since the game start until the game has ended.

**Table 2.** Action table for Morseline game

Type of Game Mode	Trigger	Object	Action	Result
All types	Check if players have joined game lobby	Player	Load proper game scenario	Game starts
All types	Move to checkpoint	Player	Listen to Morse code on telegraph	Player chooses correct answer
All types	Choose letter that matches listened Morse code	Letter	Reply sent to server	Server waits for all players answers and then proceed them to next checkpoint
All types	Last checkpoint	Lobby	Players reached final checkpoint	Triggers game as finished
1v1 and 1v1v1v1	Check results	Lobby	Calculates new player ratings	Updates player ratings on the server and marks lobby as finished
Cooperative	Check checkpoints progress	Lobby	Players met the necessary criteria	Quest is marked as successful or failed
All types	Game has ended	Server	Verifies if all preceding criteria is verified	Removes players from lobby and sends them back to main menu

After a user picks his desired game mode, he's placed in a queue where he will meet users that are in his range of skill level. With the help of a DDA (Dynamic Difficulty Adjustment), the user will never matchup with someone of much higher or lower skill, but instead with someone of similar competitive level.

When the server meets the necessary players to start a game and allocates them to a game lobby, a message is broadcasted using sockets meaning that an opponent is found and therefore the game will start. Afterwards, when both users connect to the lobby, they are shown a different scenario, and while blind users have audio support given by the implemented voice assistant, deaf users will have their accessibility needs fulfilled by the Portuguese Sign language avatar (Fig. 5). Moving towards to the first checkpoint, both players will have Morse cues (either by sound or image) and they have unlimited time to pick the correct answer. Next, a reply is sent to the server where user's answers will be processed and saved while the game is running. It was mentioned before that a DDA is used, and when playing the game, difficulty is adjusted using both user's correct answer streak.



**Figure 5.** Checkpoint example in a one versus one matchup from a deaf user (left) and blind user (right) interface accessibility point of view

Since it is a multiplayer game, real time difficulty adjustment must be fair for both users so that one won't have a significant advantage against the other. Reaching the final checkpoint and answering the last Morse code message, judging by the answers given, server will then calculate the final score and present it via audio or image to all users inside the game lobby. While one-on-one and four users' modes have a competitive rating, cooperative mode doesn't have that, since its purpose is to let users help with each other along the way.

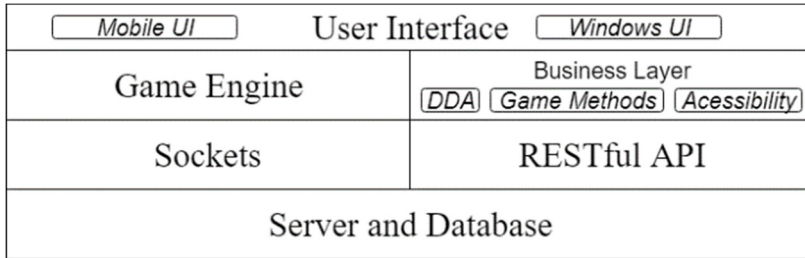

**Figure 6.** Morseline application architecture

The game is divided into four layers. At the top level there is the user interface. All game functionalities can be accessed through this layer by the user on his preferred device. Actions transmitted by the user go through the following layers. The second layer is where all client-side code is developed, with business layer component containing the DDA, game and accessibility scripts which linked with Unity offer an accessible front-end for its users. The next level which contains sockets and a RESTful API, help pass through information sent and received on users end between the game and server. The fourth layer represents the game back-end, where persistent data is stored with the help of an online hosted database hosted.

### 3 Evaluation

We normally use three steps of the Social Networking Learning [17] model to evaluate our learning objects:

1) Pedagogical module

- Teaching strategies: The principles and methods that are used for instruction.
- Learning outcome: The system analyses the achievement of the students' learning outcome during the tutoring process.

2) Personalization

- Adaptive interface: It includes adaptive presentation and adaptive navigation. Adaptive presentation is to display certain information based on user's characteristics. For instance, the system will provide more detailed information and capabilities to a user with advanced knowledge level. Adaptive navigator intends to assist users in achieving their learning goals through the presentation of the appropriate options, such as enabling/disabling topics' links.
- Advice generator: It is a component that responds to user when an error is occurred, about the cause of the error, in order to help him or her.

- Error diagnosis: It is a module that can identify the category of assessment's mistakes based on associated misconceptions with the use of algorithmic approaches.
- 3) Usability
- User interface friendliness: The system is easy to be learned and used.

## 4 Conclusion

This work presented guidelines for the design of serious games for deaf and blind people. The process of building digital games, which is based on a diverse set of tasks, requires the structuring of a multidisciplinary team capable of developing pedagogical, linguistic and techniques. We hope that the guidelines provided alongside with system architectures designed for specific accessibility needs, help game designers and game developers to achieve successful implementation in inclusive games, so that players can have an enjoyable learning experience.

In this way, we conclude that the references of multimedia learning combined with the guiding principles of the education of the deaf and blind create a line of development possible, with innovation and interdisciplinary methods, to a deepening of knowledge capable of contributing to the qualitative expansion in the production of inclusive serious games.

## Acknowledgments

This work was supported by FCT/ COMPETE2020 – project ACE ref: PTDC/IVC-COM/5869/2014, POCI-01-0145-FEDER-016584), by ISEP (Instituto Superior de Engenharia do Porto), and GILT (Games, Interaction and Learning Technologies).

## References

- [1] The Entertainment Software Association. "Essential Facts About The Computer and Video Game Industry", *Theesa*, 2018, <http://www.theesa.com/article/essential-facts-computer-video-game-industry-2018/> (accessed May 27, 2019).
- [2] J. Huizinga, *Homo Ludens: a study of the play element in culture*, London, Maurice Temple Smith Ltd., 1970.
- [3] E. M. Avedon and B. Sutton-Smith, *The Study of Games*, J. Wiley New York, 1971.
- [4] C. Crawford, *The Art of Computer Game Design*, New York, NY, USA, McGraw-Hill, Inc., 1984.
- [5] M. Zyda, "From visual simulation to virtual reality to games," *Computer*, vol. 38, n. 9, p. 25–32, 2005, doi:10.1109/MC.2005.297

- [6] B.H. Sørensen and B. Meyer, "Serious games in language learning and teaching: a theoretical perspective," in *Proceedings of the 2007 Digital Games Research Association Conference*, Tokyo, pp. 559-566, 2007.
- [7] T. Cardoso, V. Santos, C. Santos and J. Barata, "Games' Social Tech Booster," In: C. V. de CARVALHO et al. (eds.). *Serious Games, Interaction, and Simulation*, Lecture Notes of the Institute for Computer Sciences, Social Informatics and Telecommunications Engineering, Springer International Publishing, pp. 119–126, 2016.
- [8] D. Grammenos, A. Savidis and C. Stephanidis, "Designing Universally Accessible Games," *Comput. Entertain.*, vol. 7, n. 1, 2009 doi:10.1145/1486508.1486516.
- [9] R. E. Mayer, *The Cambridge handbook of multimedia learning*, The Cambridge handbook of multimedia learning, New York, NY, US, Cambridge University Press, 2005, doi:10.1017/CBO9780511816819.
- [10] C. H. Rodrigues and R. M. Quadros, "Diferenças e linguagens: a visibilidade dos ganhos surdos na atualidade," *Revista Teias*, vol. 16, n. 40, p. 72–88, 2015.
- [11] B. J.B. Galasso, D. T. R. Souza, "Educação online colaborativa: implicações teórico-metodológicas de uma nova modalidade de ensino e aprendizagem," *Revista História Hoje*, vol. 3, n. 5, p. 43–60, 2014, doi:10.20949/rhhj.v3i5.125.
- [12] R. E. Mayer, "Multimedia learning: Are we asking the right questions?," *Educational Psychologist*, v. 32, 1997, doi:10.1207/s15326985ep3201\_1.
- [13] F. Paas and J. Sweller, "Implications of cognitive load theory for multimedia learning," *The Cambridge handbook of multimedia learning*, 2nd ed. pp. 27–42, IONDOM, Cabridge University Press, 2014, doi:10.1017/CBO9781139547369.004.
- [14] J. Beksa, S. Fizek and P. Carter, "Audio Games: Investigation of the Potential Through Prototype Development" In: PRADIPTA BISWAS et al. (eds.). *A Multimodal End-2-End Approach to Accessible Computing*. Human–Computer Interaction Series. London, Springer London. pp. 211–224, 2015, doi:10.1007/978-1-4471-6708-2\_11.
- [15] L. Salvador-Ullauri, A. Jaramillo-Alcázar and S. Luján-Mora, "A Serious Game Accessible to People with Visual Impairments", *9th International Conference on Education Technology and Computers Proceedings*, Barcelona, 2017, doi:10.1145/3175536.3175576.
- [16] Á. Csapó, G. Wersényi, H. Nagy and T. Stockman, "A survey of assistive technologies and applications for blind users on mobile platforms: a review and foundation for research," *Journal on Multimodal User Interfaces*, vol. 9, n. 4, pp. 275–286, 2015, doi:10.1007/s12193-015-0182-7.
- [17] M. Krouska, C. Troussas and M. Virvou "A literature review of Social Networking-based Learning Systems using a novel ISO-based framework". *Intelligent Decision Technologies*, vol. 13, n. 1, p. 23-39, 2019.



# Students' Perception of Self-efficacy and Academic Engagement in School of Health of the Polytechnic Institute of Porto: an Observational Study

Manuela Amorim<sup>1</sup>, Diana Tavares<sup>2</sup>, Maria Céu Lamas<sup>1</sup>, Sandra Mota<sup>1</sup>,  
Ana Salgado<sup>2</sup>

<sup>1</sup> School of Health Polytechnic Institute of Porto (ESS|P.Porto), Portugal; Health and Environment Research Centre (CISA), Polytechnic Institute of Porto, Rua Dr. António Bernardino de Almeida, 400 4200 - 072, Porto Portugal, Portugal, {mas, mcl, smm}@ess.ipp.pt

<sup>2</sup> School of Health Polytechnic Institute of Porto (ESS|P.Porto), Portugal; Center for Rehabilitation Research (CIR), Polytechnic Institute of Porto, Rua Dr. António Bernardino de Almeida, 400 4200 - 072, Porto Portugal, Portugal, {dpt, ais}@ess.ipp.pt

**Abstract:** *The intense increase in students in Higher Education, observed in recent decades, has promoted profound changes quantitative and qualitative in demand, frequency, and student profile. In the context of these changes, we conducted a study to evaluate the self-efficacy and academic engagement of students using an online questionnaire. It includes some sociodemographic variables and the Self-Efficacy Scale in Higher Education (AEFS) and University Student Engagement Inventory (USEI). It was possible to verify that students had a score for academic engagement above the average, revealing an overall high level of academic engagement, an indicator of student success. Regarding self-efficacy, the score obtained is above 4 (on a scale of 1 to 5), close to 5, in social interaction, which indicates that these students overall have relatively robust self-efficacy beliefs. In all cases, the low values of standard deviation reveal a good degree of agreement between responses.*

**Keywords.** Higher education, students, academic performance, self-satisfaction, USEI, AEFS

## 1 Introduction

Higher education is changing rapidly in different directions. The students profile is being increasingly diverse, reinforcing the need for new ways of understanding student experience to ground policy and practice (Kahu & Nelson, 2018). From an institutional perspective it is almost imperative to identify the best conditions for academic success and find strategies that prevent students from dropping out of their school career (e.g., Maroco et al., 2016).

First step could be to identify and evaluate the dimensions that can compromise students' academic engagement and performance and in some even cause attrition. Several studies show that students' study performance (or academic performance) can be influenced by, for example, the environment in which they operate (Salanova et al., 2010), past performance (Elias & MacDonald, 2007), actual skills (Brown et al., 2008), and health (Trockel, Barnes, & Egget, 2000). Sometimes in the same classroom some students are involved, engaged, and motivated for schoolwork and others are disengaged and apathetic. There are no single "right" answers for this chronic problem in education. Teachers at all levels, are always concerned with increasing student engagement and learning.

Some researchers focus on student agency and motivation as factors in engagement (Schuetz, 2008). Others highlight the way educators practise and relate to their students (Kuh, 2001) and the roles of institutional structures and cultures (Porter, 2006). Yet others spotlight the socio-political context in which education and engagement take place (McMahon and Portelli, 2004) and the impact on students of environmental factors such as family background and economic status (Law, 2005).

Bryson (2014) suggests that student engagement is a black box and draws on a metaphor of quantum mechanics to argue that the complexity of student engagement is such that we cannot measure or map all its properties. Like Kahu (2013) argue that institutional factors and structural factors in a student's background are related to student engagement, and engagement results from the complex interplay between factors.

Nowadays, there is no unanimity among researchers. First studies on engagement had their origins in organizational and occupational areas (Schaufeli et al, 2002a; 2002b), conceptualized as being the opposite of burnout, constituting the two poles of the same continuum. Schaufeli et al. (2002b), for their part, conceptualized the engagement as a positive, persistent and comprehensive affective-cognitive state, which is characterized for stamina – high energy levels, mental toughness, willingness to invest effort in professional activity and persistence in the face of difficulties at work; dedication – strong engagement in work, enthusiasm, pride, audacity and inspiration in the performance of the professional function; and absorption - "immersion" and total concentration on what you are doing.

Student engagement has been linked to an array of traditional success factors such as increased retention (Khademi et al., 2018); academic achievement, high impact and lifelong learning (Artess et al., 2017), curricular relevance, enhanced institutional reputation, increased citizenship behaviours, student perseverance and work-readiness (Khademi et al., 2018). It has also been linked to more subjective and holistic outcomes for students themselves including social and personal growth and development, transformative learning (Kahu 2013);

enhanced pride, inclusiveness and belonging (Wentzel, 2012); student wellbeing (Almeida et al., 2012; Fredericks et al., 2004). Engagement has been defined as ‘the quality of effort students devotes to educationally purposeful activities that contribute directly to desired outcomes’ (Hu & Kuh 2002, 555). Most definitions of student engagement cover the emotional, behavioural and cognitive engagements (Coates, 2006; Fredricks et al., 2004) and “agentic engagement” (Reeve & Tseng, 2011).

Fredricks et al. (2004) propose a model that considers academic engagement as a three-dimensional construct, which includes the behavioral, emotional, and cognitive dimensions. The engagement behavior is manifested by the student's participation in academic activities, social and extracurricular activities that take place at school or are related to it; emotional engagement reflects positive and negative reactions to teachers, peers and school requirements, particularly in relation to the course and codes of conduct, building bonds with school and peers, and willingness to do required schoolwork; and finally, cognitive engagement manifests itself in the investment and willingness to make the necessary efforts to understand and internalize complex ideas and skills with a high degree of difficulty (Fredricks et al., 2004; Fredricks & McColskey, 2013; Maroco et al., 2016). Student engagement have been nonetheless considered the strongest predictors of students’ performance, as well as self-efficacy beliefs (Richardson, Abraham & Bond, 2012).

Literature confirms the positive relationship between self-efficacy and engagement as well. Self-efficacy leads to a greater willingness to expend additional energy and effort on completing a task or an assignment, and hence to more task engagement and absorption (Ouweneel et al., 2011). Efficacious students are more likely to regulate their motivation by setting goals for themselves (Diseth, 2001), and are therefore more likely to be engaged (Howell, 2009). They tend to try other options when they do not achieve their goals at first, they expend high levels of effort in doing so, and deal more effectively with problematic situations by persevering and remaining confident that they will find solutions and be successful in the end. Therefore, generally, they perform well (Bandura, 1997). Moreover, this seems to be stable across different ages for all students in elementary, junior high, high school, and college classrooms. It seems to apply equally to males and females and all ethnic groups (Pintrich & Schunk, 1996).

Students’ efficacy beliefs can be altered and promoted in several ways: by mastery experiences, vicarious learning, social persuasion, and specific psychological states (Bandura 1997). In meta-analyses, self-efficacy has emerged as a strong predictor of motivation, persistence, and performance over time, in different environments and populations (Bandura, 2006; Elias & MacDonald, 2007; Azzi & Polydoro, 2010).

Bandura's (1986) sociocognitive theory defines self-efficacy as the individual's perceptions of their ability to perform a task. Social cognitive theory views human functioning in a transactional way, depending on reciprocal interactions between an individual's behaviours, their internal personal factors (e.g., thoughts and beliefs), and environmental events (Bandura, 1986, 1997). An analysis of students' self-efficacy beliefs is very important to understand how their actions, insofar as the subject is able to perform, but what they believe they can perform (Schunk, 1995, 2003; Bandura, 1986). Such belief has been associated with

the development of critical thinking, to the value assigned to the task, to self-regulated learning, to the performance of students, engagement with the course, academic persistence and integration into the higher education (Guerreiro-Casanova & Polydoro, 2011; Mascarenhas et al., 2013).

According to Jones (2010), students, depending on their self-efficacy perceptions, can adopt three behavioral alternatives: investing in the task, spending the necessary effort to be successful; consider that success depends only on the superior capabilities you have; or avoid work, thinking that success in school is easy to achieve, so it is not necessary to make a great effort. For Gore (2006) experiences of success or failure are associated with strong or weak beliefs of personal effectiveness and are predictive of performance for university students. Zusho and Pintrich (2003) add that these beliefs may fluctuate throughout the year as a result of the numerous performance feedback given to students, with low-achieving students reporting less confidence than high-achieving students. The latter, in turn, attach greater value to their learning.

Research data reveal that students, who usually believe that are capable of performing the proposed academic tasks, use more cognitive and metacognitive strategies in their academic work and set more challenging goals than those students who build beliefs adverse to school investment. This achievement behavior, in turn, influences personal variables, because as a student progresses in a task (behavior), he mentally records his progress, and this record conveys the feeling that he is capable of learning, reinforcing, thus, their perceptions of self-efficacy in that task and similar tasks (Bandura, 1986, 1997).

According to Chen and Zimmerman (2007), the harmony between self-efficacy and performance is fundamental and promotes the regulation of behavior. Students who self-regulate their learning usually show robust self-efficacy in the different curricular units, that is, they believe more that they can learn or perform behaviors according to what is required and expected; this being a key variable in the students' self-regulatory process. Students with high self-efficacy, as stated by Zimmerman (2000), tend to be more persistent, to choose difficult tasks, to control their anxiety by resorting more to self-regulatory processes, such as setting goals, defining, and selecting strategies, self-monitoring and self-assessment.

The purpose of this work was to evaluate the self-efficacy and academic engagement of students at School of Health Polytechnic Institute of Porto (ESS|P.Porto), as well as to correlate the level of self-efficacy and academic engagement with academic success.

## 2 Methodology

This was an analytical cross-sectional study. The study project was previously submitted for analysis by the Ethics Committee of the ESS|P.Porto, having received a favorable opinion. Participants were recruited through institutional emails, where were request for collaboration to respond the questionnaire available via Google forms, the link was included in the body of the text of the email sent, without identifying data, which include some sociodemographic variables and the instruments Self-Efficacy Scale in Higher Education (EAFS) and University

Student Engagement Inventory (USEI). The inclusion criteria were being of legal age and student at ESS|P.Porto. There are no specific exclusion criteria other than situations if most part of the questionnaire was not completed.

The information collected and the respective procedures will comply the Regulation 2016/679 of the European Parliament and of the Council of 27 April 2016. The pseudo-anonymization process will be guaranteed by the absence of registration and collection of data identifying the participants, so that the data collected cannot be attributed to a particular person, thus guaranteeing their confidentiality. The data obtained were descriptively and inferential analyzed, and statistically significant differences were considered for an  $\alpha$  of 0.05.

### 3 Results

#### 3.1 Sample characterisation

In our study, 105 answers were obtained, however, 3 participants were excluded because they were Master's degree students and were not the target of our study. Thus, our sample is composed of 102 respondents, mostly female, 83.3% ( $n=85$ ), aged between 18 and 46 years (Fig.1), with a mean age of  $22\pm 4$  years.

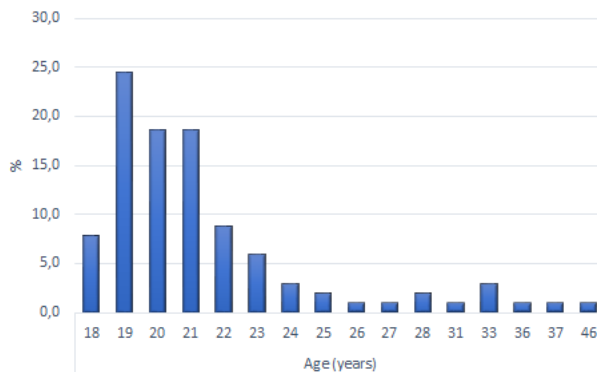

**Figure 1.** Distribution of ages of study participants, in percentage.

In relation to the level of education of the students' parents, it was found that for the mothers the most frequent level of education is secondary education and second cycle, both with 26.5%, followed by higher education with 18.6%. In the case of the fathers, the most frequent level of education was secondary education with 28.4%, followed by secondary education with 26.5% and third level with 20.6% (Fig. 2).

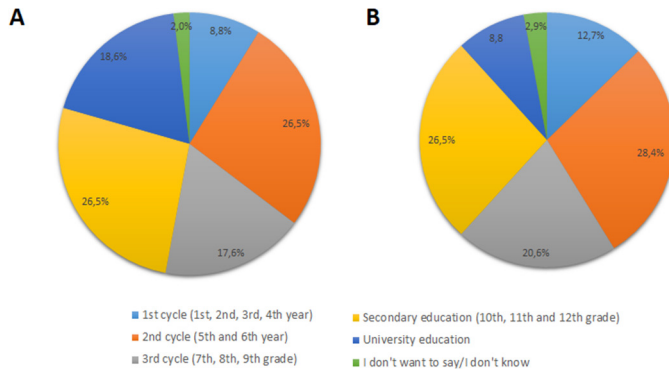

**Figure 2.** Academic qualifications of the students' parents. A) Academic qualifications of the mother, B) Academic qualifications of the father.

Our study included students from 11 four-year degree courses at ESS|P.Porto; the distribution by course is shown in Fig. 3 (A). For most students, 52.9% (n=54), their course was their first choice. In Fig. 3B we can highlight that most respondents are attending their second year of study (41.2%; n=42).

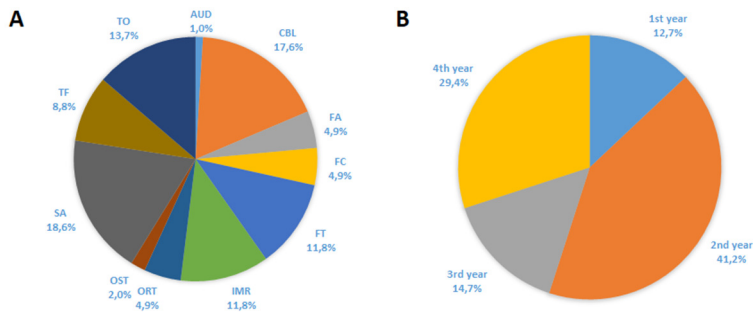

**Figure 3.** Distribution of students by course (A) and by year of study (B). A sample n of 102 and B sample n of 100. AUD - Audiology, CBL - Biomedical Laboratory Sciences, FA - Pharmacy, FC - Clinical Physiology, FT - Physiotherapy, IMR - Medical Imaging and Radiotherapy, ORT - Orthotics, OST - Osteopathy, SA - Environmental Health, TF - Speech Therapy, TO - Occupational Therapy

Only 7.8% (n=8) of our sample has overdue Curricular Units, seven students have only one overdue Curricular Unit and one student two. Regarding the course average the majority of students 51.0% (n=52) presents an average between 14 and 15.9 points, followed by 33.3% of the sample with an average between 12 and 14.9 points. In the question if the course is meeting expectations 80.4% (n=82) of the students said yes.

### 3.2 Self-Efficacy Scale Higher in Education

The instrument AEFS comprises 20 response items on a 6-position scale where 1 corresponds to not at all confident and 6 totally confident. We obtained an n=102 for each item. Table 1 shows that most questions do not cover the entire range of answers, with the most common

answers variation being between 2 and 6. The mean of answers varies between the minimum value  $3.79 \pm 0.79$  in item 19 and the maximum value of  $5.39 \pm 0.83$  in item 14. We also highlight those items 7,10,11,13 and 14 have mean values higher than 5.

**Table 1.** Results obtained for each item: minimum, maximum, mean, standard deviation, asymmetry, kurtosis.

Items	Min	Max	Average	Standard deviation	Asymmetry	Kurtosis
It1	2	6	4.47	0.82	-0.29	0.05
It2	1	6	4.02	0.97	-0.51	0.28
It3	2	6	4.32	0.87	-0.22	-0.06
It4	1	6	4.97	1.08	-1.25	1.73
It5	2	6	4.25	0.84	-0.41	0.24
It6	1	6	4.25	0.99	-0.83	0.75
It7	2	6	5.04	0.95	-0.85	0.19
It8	2	6	4.52	0.90	-0.81	0.89
It9	1	6	4.41	0.97	-1.05	2.36
It10	2	6	5.17	0.86	-1.00	1.08
It11	1	6	5.01	0.98	-1.12	1.75
It12	1	6	4.4	1.20	-0.72	0.16
It13	2	6	5.02	0.91	-0.92	1.00
It14	2	6	5.39	0.83	-1.58	2.75
It15	1	6	4.68	1.14	-1.23	1.87
It16	1	6	4.38	1.22	-0.41	-0.53
It17	2	6	4.88	1.11	-0.78	-0.07
It18	2	5	3.96	0.77	-0.46	0.03
It19	1	5	3.79	0.79	-0.73	1.76
It20	1	5	3.89	0.78	-0.57	0.92

Table 2 shows the statistics for each dimension of the questionnaire: Academic Self-efficacy, Self-efficacy in regulating training and Self-efficacy in social interaction. The highest mean value was obtained in the dimension Self-efficacy in social interaction with  $4.91 \pm 0.72$ . From the data obtained by the Kolmogorov-Smirnov test, it appears that the responses obtained in each dimension do not follow a normal distribution ( $p$ -value  $< \alpha$  0.05).

We also calculated the global score (average) of the questionnaire, obtained  $4.54 \pm 0.60$ .

**Table 2.** Statistics values (average, standard deviation and normality Kolmogorov-Smirnov test) for each dimension of the questionnaire.

Dimensions	Average (Score)	Standard deviation	Kolmogorov-Smirnov p value
Academic self-efficacy (Items1,2,3,5,6,8,9)	4.32	0.70	0.007
Training regulation self-efficacy (Items 11,12,14,15,18,19,20)	4.45	0.67	0.009
Self-efficacy in social interaction (Items 4,7,10,13,16,17)	4.91	0.72	0.010

Using non-parametric statistical tests, we studied the existence of a relationship between the results obtained in each dimension of this questionnaire and the independent variables: gender, housing situation during term time, mother and father's academic qualifications, course attended, course of first choice, year of study in which the student is enrolled, existence of course units in arrears, course average, course meeting the student's expectations. The results obtained are shown in Table 3.

**Table 3.** Results of non-parametric tests between each questionnaire dimension and independent variables. Statistically significant differences between groups are signed with \* for a  $\alpha$  of 0.05.

Independent variables	Dimension	Statistical test used	P value
Sex	Academic self-efficacy	Teste U de	0.649
	Training regulation self-efficacy	Mann-Whitney	0.033*
	Social interaction self-efficacy		0.624
Housing situation during school time	Academic self-efficacy	Teste de	0.780
	Training regulation self-efficacy	Kruskal-Wallis	0.780
	Social interaction self-efficacy		0.107
Mother's academic qualifications	Academic self-efficacy	Teste de	0.631
	Training regulation self-efficacy	Kruskal-Wallis	0.383
	Social interaction self-efficacy		0.153
Father's academic qualifications	Academic self-efficacy	Teste de	0.834
	Training regulation self-efficacy	Kruskal-Wallis	0.750
	Social interaction self-efficacy		0.096
Course attended	Academic self-efficacy	Teste de	0.006*
	Training regulation self-efficacy	Kruskal-Wallis	0.102
	Social interaction self-efficacy		0.784
Was this course your first choice?	Academic self-efficacy	Teste U de	0.547
	Training regulation self-efficacy	Mann-Whitney	0.727
	Social interaction self-efficacy		0.968
In which year of the course are you enrolled?	Academic self-efficacy	Teste de	0.128
	Training regulation self-efficacy	Kruskal-Wallis	0.261
	Social interaction self-efficacy		0.859
Do you have overdue course units?	Academic self-efficacy	Teste U de	0.856
	Training regulation self-efficacy	Mann-Whitney	0.541
	Social interaction self-efficacy		0.023*
Current course average	Academic self-efficacy	Teste de	<0.001*
	Training regulation self-efficacy	Kruskal-Wallis	0.011*
	Social interaction self-efficacy		0.007*
Is the course meeting your expectations?	Academic self-efficacy	Teste U de	<0.001*
	Training regulation self-efficacy	Mann-Whitney	<0.001*
	Social interaction self-efficacy		0.007*

Table 3 shows statistically significant differences between the results obtained in some dimensions of the AEFS questionnaire and certain independent variables. Table 4 shows the means, standard deviations, and sample n for each group within each variable, in the dimensions where statistically significant differences were found for an  $\alpha$  of 0.05.



**Table 4.** Results of means, standard deviations, and sample n for each group within each variable where statistically significant differences were found.

Independent variable	Dimension	Mean± Standard Deviation (n)
Sex	Self-efficacy in regulating training	Female: 4.52±0.61 (85) Male: 4.10±0.84 (17)
Course you are attending	Academic self-efficacy	CBL: 4.37±0.70 (18) FA: 4.46±0.75 (5) FC:4.14±0.42 (5) FT: 3.54±0.68 (12) IMR:4.20±0.82 (12) ORT:5.06±0.39 (5) OST:4.64±0.10 (2) SA: 4.45±0.65 (19) TF: 4.41±0.41 (9) TO: 4.53±0.56 (14)
Do you have overdue course units?	Social interaction self-efficacy	Yes: 4.40±0.56 (8) No: 4.95±0.72 (94)
Current course average	Academic self-efficacy	Between 10 and <12: Not applicable (1) Between 12 and <14: 4.13 ± 0.62 (34) Between 14 and <16: 4.51 ± 0.59(50) Between 16 and <18: 4.56±0.85(10) Don't want to answer/Don't know: 3.23±0.79 (5)
	Training regulation self-efficacy	Between 10 and <12: Not applicable (1) Between 12 and <14: 4.24 ± 0.57 (34) Between 14 and <16: 4.64 ± 0.52 (52) Between 16 and <18: 4.61±0.72(10) Don't want to answer/Don't know: 3.57±1.41 (5)
	Social interaction self-efficacy	Between 10 and <12: Not applicable (1) Between 12 and <14: 4.76 ± 0.64 (34) Between 14 and <16: 5.04 ± 0.65 (52) Between 16 and <18: 5.33 ± 0.58 (10) Don't want to answer/Don't know: 3.83±1.14 (5)
Is the course meeting your expectations?	Academic Self-efficacy	Yes: 4.51±0.50 (82) No: 3.54±0.87 (20)
	Training regulation self-efficacy	Yes: 4.58 ± 0.52 (82) No: 3.89±0.89 (20)
	Social interaction self-efficacy	Yes: 5.03±0.60 (82) No: 4.42±0.97 (20)

Legend: AUD - Audiology, CBL - Biomedical Laboratory Sciences, FA - Pharmacy, FC - Clinical Physiology, FT - Physiotherapy, IMR - Medical Imaging and Radiotherapy, ORT - Orthotics, OST - Osteopathy, SA - Environmental Health, TF - Speech Therapy, TO - Occupational Therapy

### 3.3 University Student Engagement Inventory

University student academic engagement inventory comprises 15 response items on a 5-position scale where 1 corresponds to never and 5 always. We obtained an n=102 for each item. Table 5 presents the results obtained for each item in terms of minimum, maximum, mean, standard deviation, asymmetry, kurtosis. We observe that most of the questions are distributed throughout the response scale, except for items 2,5,14,15. Mean responses range from a minimum value of  $2.46 \pm 1.25$ , in item 6 to a maximum of  $4.57 \pm 0.55$  in item 2.

**Table 5.** Results obtained for each item: minimum, maximum, mean, standard deviation, asymmetry, kurtosis.

Items	Min	Max	Average	Standard deviation	Asymmetry	Kurtosis
It1	1	5	3.78	0.61	-0.94	3.50
It2	3	5	4.57	0.55	-0.81	-0.39
It3	1	5	4.37	0.83	-1.32	1.75
It4	1	5	3.59	0.98	-0.45	-0.29
It5	2	5	4.49	0.73	-1.22	0.60
It6	1	5	2.46	1.25	0.40	-0.97
It7	1	5	3.44	0.97	-0.46	0.05
It8	1	5	3.78	0.93	-0.69	0.41
It9	1	5	3.67	0.95	-0.85	0.88
It10	1	5	3.33	1.00	-0.41	0.10
It11	1	5	3.69	1.00	-0.62	0.10
It12	1	5	3.78	0.98	-0.71	0.37
It13	1	5	4.32	0.79	-1.40	2.85
It14	2	5	4.09	0.72	-0.30	-0.48
It15	2	5	4.08	0.75	-0.70	0.59

Table 6 shows the statistics for questionnaire each dimension: Behavioural Engagement, Emotional Engagement and Cognitive Engagement. The highest mean value was obtained in the dimension Behavioural Engagement with  $4.16 \pm 0.46$ . According to the Kolmogorov-Smirnov test, the answers obtained in each dimension did not follow a normal distribution (p-value  $< \alpha$  0.05). We obtained a questionnaire global score (average) of  $3.83 \pm 0.42$ .

**Table 6.** Statistics values (average, standard deviation, and normality Kolmogorov-Smirnov test) for each dimension of the questionnaire.

Dimensions	Average (Score)	Standard deviation	Kolmogorov-Smirnov p value
Behavioural Engagement (items 1-5)	4.16	0.46	<.001
Emotional Engagement (items 6-10)	3.34	0.55	<0.001
Cognitive Engagement (items 11-15)	3.34	0.55	0.008

Similarly, to the AEFS questionnaire, we used non-parametric statistical tests in order to study the relationship between the results in each dimension of the USEI questionnaire and the independent variables: gender, housing situation during the school period, mother's and

father's academic qualifications, the course attended, the course of first choice, the year in which the student is enrolled, the existence of course units in arrears, the course average, and whether the course meets the student's expectations. The results obtained are shown in Table 7. The analysis of this table shows that there are statistically significant differences between the results obtained in some dimensions of the questionnaire and certain independent variables. To be able to detail these differences, Table 8 shows the means, standard deviations and sample n for each of the groups within each variable, in the dimensions in which statistically significant differences were observed for an  $\alpha$  of 0.05.

**Table 7.** Results of non-parametric statistical tests between each dimension of the questionnaire and independent variables.

<b>Independent variables</b>	<b>Dimension</b>	<b>Statistical test used</b>	<b>P value</b>
Sex	Behavioural Engagement	Teste U de	0.664
	Emotional Engagement	Mann-Whitney	0.913
	Cognitive Engagement		0.629
Housing situation during school time	Behavioural Engagement	Teste de Kruskal-	0.884
	Emotional Engagement	Wallis	0.781
	Cognitive Engagement		0.391
Mother's academic qualifications	Behavioural Engagement	Teste de Kruskal-	0.943
	Emotional Engagement	Wallis	0.717
	Cognitive Engagement		0.045*
Father's academic qualifications	Behavioural Engagement	Teste de Kruskal-	0.399
	Emotional Engagement	Wallis	0.685
	Cognitive Engagement		0.580
Course attended	Behavioural Engagement	Teste de Kruskal-	0.229
	Emotional Engagement	Wallis	0.197
	Cognitive Engagement		0.139
Was this course your first choice?	Behavioural Engagement	Teste U de	0.697
	Emotional Engagement	Mann-Whitney	0.919
	Cognitive Engagement		0.233
In which year of the course are you enrolled?	Behavioural Engagement	Teste de Kruskal-	0.406
	Emotional Engagement	Wallis	0.002*
	Cognitive Engagement		0.760
Do you have overdue course units?	Behavioural Engagement	Teste U de	0.990
	Emotional Engagement	Mann-Whitney	0.171
	Cognitive Engagement		0.310
Current course average	Behavioural Engagement	Teste de Kruskal-	<.001*
	Emotional Engagement	Wallis	0.212
	Cognitive Engagement		0.006*
Is the course meeting your expectations?	Behavioural Engagement	Teste U de	.006*
	Emotional Engagement	Mann-Whitney	0.006*
	Cognitive Engagement		0.014*

Legend: Statistically significant differences between groups are signed with \* for a  $\alpha$  of 0.05.

**Table 8** - Results of means, standard deviations, and sample n for each group within each variable where statistically significant differences were found.

Independent variable	Dimension	Mean± Standard Deviation (n)
Mother's Academic Qualifications	Cognitive	1st cycle: 4.38±0.31(9)
	Engagement	2nd cycle: 4.10±0.70 (27)
		3rd cycle: 3.80±0.43 (18)
		Secondary education: 3.79±0.64 (27)
		Higher education: 4.11±0.63 (19)
		Don't want to say/Don't know: 4.30±0.71 (2)
In which year of the course are you enrolled?	Emotional	1st year: 3.49±0.52 (13)
	Engagement	2nd year: 3.28±0.56 (42)
		3rd year: 3.71±0.38 (15)
		4th grade: 3.18±0.56 (30)
Current course average	Behavioural Engagement	Between 10 and <12: Not applicable (1)
		Between 12 and <14: 3.94 ± 0.48 (34)
		Between 14 and <16: 4.31 ± 0.36 (52)
		Between 16 and <18: 4.34 ± 0.43 (10)
		Don't want to answer/Don't know: 3.88±0.50 (5)
	Cognitive Engagement	Between 10 and <12: Not applicable (1)
		Between 12 and <14: 3.82 ± 0.65 (34)
		Between 14 and <16: 4.14 ± 0.52 (52)
		Between 16 and <18: 4.26±0.65 (10)
		Don't want to answer/Don't know: 3.28±0.46 (5)
Is the course meeting your expectations?	Behavioural	Yes: 4.23 ± 0.41 (82)
	Engagement	No: 3.88±0.54 (20)
		Yes: 3.41 ± 0.53 (82)
	Emotional Engagement	No: 3.02±0.52 (20)
	Cognitive Engagement	Yes: 4.07±0.57 (82)
		No: 3.67±0.72 (20)

Legend: AUD - Audiology, CBL - Biomedical Laboratory Sciences, FA - Pharmacy, FC - Clinical Physiology, FT - Physiotherapy, IMR - Medical Imaging and Radiotherapy, ORT - Orthotics, OST - Osteopathy, SA - Environmental Health, TF - Speech Therapy, TO - Occupational Therapy

## 4 Discussion

The sample under study is mostly composed of female students (83.3%), which is in line with the trend of higher female expression seen in recent years as a result of universalization of the right to education and the massification that began in higher education in the 1960s and was reinforced after the 25th of April 1974 (Dias, 2015). On the other hand, it is in line with the student universe of ESS|P.Porto.

It was found that the average age is 22 years old, suggesting that most students enter higher education after concluding secondary or vocational education. Considering that the study was conducted on undergraduate students, the average age is appropriate. We must highlight the age distribution between 18 and 46 years old, revealing the impact of the special

access route to higher education that allows the application of professional, higher technical courses and undergraduate degrees for those over 23, as established by Decree-Law 64/2006.

The level of education of the parents of the surveyed students differs according to their gender. In the case of mothers, it corresponds mostly to secondary and lower secondary education (both 26.5%), followed by higher education (18.6%), while 28.4% of fathers have lower secondary education and 26.5% have upper secondary education. Compared to mothers, only 8.8% have a higher education. Overall, despite the positive evolution, it is likely that the full democratization of this level of education has not yet been achieved (Dias, 2015; Cerdeira & Cabrito 2018).

In the responses obtained, 11 undergraduate courses out of the 12 existing at ESS|P.Porto are represented. The courses with the highest frequency of answered questionnaires were Environmental Health (SA), Biomedical Laboratory Science (CBL) and Occupational Therapy (OT) (Fig. 2A). Most respondents are attending the course they chose as their first option (52.9%), and 41.2% are attending the second curricular year.

At the time of the study, the vast majority (92.2%) had no curricular units (CU) in arrears, and when this happened, only eight students (7.8%) had unapproved CU, almost exclusively one. The course grade, at present for most students (51.0%), is between 14 and 15.9, 33.3% have a lower grade, and 9.8% have a grade between 16 and 18. In view of these rates, we can consider this a good academic performance. Theoretically, it is expected that the higher the self-efficacy in an area, the greater the success in performing it (Vieira et al., 2017).

For 80.4% of the respondents, the course they attended met their expectations. In this context, and although the justifying answers were scarce, it was the students attending the 2nd curricular year who expressed themselves the most. They are related to the diversified perspective of the course performance area (CBL) and the several professional outlets (SA), the practical component that allows the acquisition of skills for the labour world (FT), the proximity of the teachers, allowing the clarification of doubts, and the interconnection of contents within the same CU, of increasing complexity to promote intellectual and pedagogical growth (FT). Those who considered that the course fell short of their expectations considered that some topics did not seem useful for the future work context (SA), the topics were dealt with in a superficial way (TO) and there was a feeling of not being prepared to intervene in a therapeutic context with the desired effectiveness (TO). The workload was exaggerated and incompatible with work-life balance, associated with a lack of organization and justified by the PBL teaching method (FT). In addition, there is some difficulty in keeping up with the classes (FT). Although some respondents answered "Yes", they also highlight the need for greater organization between course units (FT), greater practical focus, and the existence of CUs that do not fit into the course (ORT) as well as the overvaluation of one component over the others (IMR).

The AEFs aims to assess the student's confidence in his/her ability to succeed in the tasks arising from attending higher education. Divided into three dimensions: academic self-efficacy, self-efficacy in regulating training, and self-efficacy in social interaction, it shows that

the higher the score in each dimension, the higher the student's self-efficacy in the respective dimension.

According to Schunk (1994), from a sociocognitive standpoint, self-efficacy is a condition that can be regulated and adjusted, much like other learning strategies that the student may employ. The same author (1989) contends that teaching students how to use learning strategies increases self-efficacy by creating, *a posteriori*, a sense of personal control over the outcomes of activities and a sense of ability to select and implement the various learning techniques taught. In this approach, an unbreakable link between cause and effect is established.

Additionally, Vogt (2008) found a strong correlation between perceived self-efficacy, confidence, performance, and interaction with teachers. This perspective, associated with curricula, could be explored to understand the degree of influence as investigated by Jones (2010). Other studies have also revealed positive and significant correlations between perceived self-efficacy and competent performance (Schunk & Gunn, 1986), suggesting that self-efficacy promotes employability orientation (Nauta et al., 2009).

However, as DiBenedetto and Bembenutty (2013) suggest, in the future, the contributing elements to the decrease in self-efficacy along the university academic pathway should be investigated. Specifically, those that directly or indirectly influence decision-making.

The descriptive statistical analysis of the 20 items of the AEFS (Table 1) shows that in 50% of the items, the answers range from 1 to 6, using all possible response alternatives on the scale, namely in items 2, 4, 6, 9, 11, 12, 15, 16, 19 and 20. These items are mainly related to self-efficacy in training regulation and academic self-efficacy; only items 4 and 16 are related to self-efficacy in social interaction. The mean responses to the items range from a minimum value of 3.79 (SD = 0.79) in item 19 to a maximum value of 5.39 (SD = 0.83) in item 14, although items 7, 10, 11, 13, and 14 also have mean values above 5. Except for items 9 and 14, the asymmetry (Sk) and kurtosis (Ku) values are within the limits considered normal, since all absolute values are less than 2. However, normality was tested, and it was found that the responses by dimension do not follow a normal distribution (table 3).

Based on some studies conducted in this area on the Portuguese population (Polydoro et al., 2008; Vieira, 2010, 2012), we also assumed as a reference that scores  $\leq 3$  in the subscales indicate low levels of self-efficacy in the respective dimension, and that scores  $\geq 5$  correspond to robust self-efficacy in the various dimensions. In our study, the mean scores obtained were higher than 4, the highest in the dimension of self-efficacy in social interaction, with  $4.91 \pm 0.72$ , revealing a high confidence in the ability to relate with peers and teachers. Although the results in the other dimensions are slightly lower, academic self-efficacy (4.32) and self-efficacy in regulating training (4.45), they also demonstrate a high ability, on average, to learn, demonstrate, and apply the course content, as well as to set goals, plan, meet deadlines, and self-regulate their actions during the teaching-learning process, respectively.

Considering that the sample did not follow a normal distribution in some items, possible relationships between the results obtained in each dimension and the independent variables were studied using non-parametric tests (Table 4). It was found that academic self-efficacy is related to the course attended, the current course average, and whether the course is meeting

individual expectations. Self-efficacy in regulating training is related to the student's gender, current course average, and whether the course is meeting expectations. Finally, self-efficacy in social interaction is related to the current course average and individual expectations about the course.

Thus, female students show higher self-efficacy in regulating education compared to male students ( $4.52 \pm 0.61$  and  $4.10 \pm 0.84$ , respectively). This is in line with the study by Shull & Weiner (2002), who found significant differences in the perception of self-efficacy between female and male students. The courses attended, despite being related to academic self-efficacy, had low sample values per course, so we considered that we were dealing with a very heterogeneous profile representing important possible biases. The fact that students do not have UC in arrears contributes to a level of self-efficacy in social interaction close to 5 ( $4.95 \pm 0.72$ ), which represents almost a robust self-efficacy in this dimension.

The current course average and whether the course is meeting expectations are the only variables that interfere with all three dimensions of the scale. In the former case, as course grades increase, self-efficacy averages increase, regardless of dimension. Of note, in social interaction self-efficacy, students with higher course grades between 14-16 and 16-18 show robust self-efficacy ( $5.04 \pm 0.65$  and  $5.33 \pm 0.58$ ). In the second case, the fact that the course is meeting individual expectations contributes to high levels of academic self-efficacy ( $4.51 \pm 0.50$ ) and training regulation ( $4.58 \pm 0.52$ ) and robust self-efficacy levels in social interaction ( $5.03 \pm 0.60$ ). The student academic engagement questionnaire (USEI) has three dimensions: emotional engagement, cognitive engagement, and behavioural engagement. The higher the score in each dimension, the higher student's engagement was in that dimension. It is possible to consider the midpoint or middle value of each subscale, situated at value 3, to analyse the results in comparison with this value, and they may be below or above the reference value. Therefore, the results may correspond to low and high levels of academic engagement for each of the subscales considered (Costa and Marôco, 2017).

A descriptive statistical analysis was performed for the 15 items in the inventory, summarized in Tables 6 and 7. We can see that for most items, the questionnaire is used in its entirety, in which the responses range from 1 to 5 (exception for items 2, 5, 14 and 15, whose response range is 2 to 5). The mean of the responses to the items lies between the values of 2.46 ( $SD = 1.25$ ) obtained for item 6 and 4.57 ( $SD = 0.55$ ) obtained for item 2. Except for items 1 and 13, the values of skewness (Sk) and kurtosis (Ku) are within the limits considered normal, as all absolute values are less than 2. However, normality was tested, and it was found that the responses by dimension do not follow a normal distribution (table 8). Behavioural engagement, in this study, is assumed to be the factor that contributes the most to student academic engagement ( $4.16 \pm 0.46$ ), representing high engagement.

Using nonparametric tests, we studied possible relationships between the results obtained in each dimension and the independent variables (table 9). It was found that cognitive engagement is positively related to the mother's academic qualifications, current course average, and expectations about the course ( $p < 0.05$ ). Emotional engagement is related to the year attended and to the individual's expectation about the course ( $p < 0.05$ ), while behavioural engagement is associated with the current course average ( $p < 0.05$ ). Thus, we can

conclude that student academic engagement is most affected by the variables current course average and course expectancy because they impact all three dimensions. The current course average for students with grades between 12 and 18 contributes to high academic engagement for each of the subscales considered. As for whether the course is meeting each student's expectations, it has more impact on behavioural and cognitive engagement ( $4.23 \pm 0.41$  and  $4.07 \pm 0.57$ , respectively).

Considering that no average scores of 3 or below were obtained in this sample, we found no students at risk for poor academic performance, which demonstrates an overall high level of academic engagement. Although it is possible and desirable to develop interventions to promote greater academic success.

## 5 Conclusion

The sample size is the study's main limitation, given the time period. The sample size will have to be increased in the future to analyse the variables related to the various dimensions. The development of longitudinal studies may be relevant to the themes studied.

It was possible to verify that students had an average score for academic engagement above the average value (value 3), which reveals an overall high level of academic engagement, an indicator of student success. The same is true when we analyse each component separately, where the low values of the standard deviation reveal a good degree of agreement among the answers. Despite the unpretentious predictive power of the AEFS in relation to academic performance (a variable subject to multiple factors in addition to aspects of self-efficacy), the results obtained should be integrated due to their potential to explain performance. It also suggests ways to intervene preventively with students who have low levels of self-efficacy in higher education.

Regarding self-efficacy, the score obtained is above 4, and very close to 5, in social interaction, which indicates that these students overall have relatively robust self-efficacy beliefs. In all cases, the low values of standard deviation reveal a good degree of agreement between responses.

However, we must not forget that the information obtained refers to a moment of self-efficacy beliefs and does not show their dynamic nature. From this perspective, Bandura (1986) defines the main sources of self-efficacy as: experiences of success experienced or observed; verbal persuasion; and physical and emotional states. As a result, in future studies, it will be essential to recognize the current perspectives of students in order to direct future intervention efforts. In this scope, several interventions may be of added value: the development of interventions streamlined by student support office and close collaboration with course coordinators and/or the students' association; the monitoring of needs; reflection and management in the course councils, monitoring committees, and course evaluation.

On the other hand, the AEFS might be discussed in higher education instructors' pedagogical training, where the reflective examination of the AEFS items could stimulate



---

and/or build the teachers' intervention capacity in order to increase students' self-efficacy in academic training.

## References

- Almeida, Leandro & Guisande, M. & Paisana, Joanne. (2012). Extra-curricular involvement, academic adjustment and achievement in higher education: A study of Portuguese students. *Anales de Psicología*. 28. 860-865. 10.6018/analesps.28.3.156231.
- Artess, J, Hooley, T., Mellors-Bourne, R 2017, *Employability: a review of the literature 2012 to 2016*, Higher Education Academy, York. <http://hdl.handle.net/10545/621285>.
- Azzi, R. G., & Polydoro, S. A. J. (2010). O papel da autoeficácia e autorregulação no processo motivacional. In E. Boruchovitch, J. A. Bzuneck & S. E. R. Guimarães (Orgs.), *Motivação para aprender: Aplicações no contexto educativo* . (pp.126-144). Rio de Janeiro: Ed. Vozes.
- Bandura, A. (1986). *Social foundations of thought and action: A social cognitive theory* . Englewood Cliffs, NJ: Prentice Hall.
- Bandura, A. (1997). *Self-efficacy, the exercise of control* . New York: Freeman and Company.
- Bandura, A. (2006). Guide for constructing self-efficacy scales. In F. Pajares & T. Urdan (Orgs.), *Self-efficacy beliefs of adolescents* (pp. 307- 337). USA Greenwich, CT: Information Age Publishing.
- Bradley, D., Noonan, P., Nugent, H., & Scales, B. (2008). *Review of Australian higher education final report*. Canberra: Government Printing Service.
- Brown, S.D., Tramayne, S., Hoxha, D., Telander, K., Fan, X., & Lent, R.W. (2008). Social cognitive predictors of college students' academic performance and persistence: A meta-analytic path analysis. *Journal of Vocational Behavior*, 72(3), 298–308.
- Bryson, C. (2014). Clarifying the concept of student engagement. In C. Bryson (Ed.), *Understanding and developing student engagement* (pp. 1–22). Abingdon: Routledge.
- Cerdeira, L., Cabrito, B. 2018. Democratização e acessibilidade no ensino superior em Portugal : mudanças recentes. *Education*, 40(1). <https://doi.org/10.4025/actascieduc.v40i1.40632>
- Chen, P.P., & Zimmerman, B. (2007). A Cross-National Comparison Study on the Accuracy of Self-Efficacy Beliefs of Middle-School Mathematics Students. *The Journal of Experimental Education*, 75, 221 - 244.
- Coates, H. (2006). *Student engagement in campus-based and online education*. Routledge.

- Costa, A.R., Marôco, J. 2017. Inventário de envolvimento académico dos estudantes do ensino superior. Coord. Almeida, L. S., Simões, M. R., Gonçalves, M. M. 2017. Adaptação, Desenvolvimento e Sucesso Académico dos Estudantes do Ensino Superior: Instrumentos de avaliação. ADIPSIEDUC Edições. ISBN 978-989-99517-1-6
- Decreto-Lei nº 64/2006, de 21 de março. Diário da República, I Série-A, N.º 57 de 21 de Março de 2006. Disponível em <https://dre.pt/application/file/a/667872>
- Dias, D. 2015. Has massification of higher education led to more equity? Clues to a reflection on Portuguese education arena. *International Journal of Inclusive Education*, 19(2), 103–120. <https://doi.org/10.1080/13603116.2013.788221>
- Dibenedetto, M., Bembenutty, H. 2013. Within the pipeline: Self-regulated learning, self-efficacy, and socialization among college students in science courses. *Learning and Individual Differences*. 23. 218-224. 10.1016/j.lindif.2012.09.015.
- Diseth, Å. (2001), Validation of a Norwegian version of the Approaches and Study Skills Inventory for Students (ASSIST): Application of structural equation modelling”. *Scandinavian Journal of Educational Research* , 45 (4), 381-394.
- Elias, S.E., & MacDonald, S. (2007). Using past performance, proxy efficacy, and academic self-efficacy to predict college performance. *Journal of Applied Social Psychology*, 37(11), 2518–2531.
- Fredricks, J. A., Blumenfeld, P., & Paris, A. (2004). School engagement: Potential of the concept, state of the evidence. *Review of Educational Research*, 74(1), 59–109. doi:10.3102/00346543074001059
- Fredricks, J. A., & McColskey, W. (2013). The measurement of student engagement: A comparative analysis of various methods and student self-report instruments. In S. L. Christenson, A. L. Rechly, & C. Wiley (Eds.), *Handbook of research on student engagement* (pp.763-782). New York: Springer Science + Business Media.
- Gore PA 2006. Academic self-efficacy as a predictor of college outcomes: Two incremental validity studies. *Journal of Career Assessment*, 14: 92-115. doi: 10.1177/1069072705281367
- Guerreiro-Casanova, D. C., & Polydoro, S. A. J. (2011). Autoeficácia e integração ao ensino superior: Um estudo com estudantes do primeiro ano. *Psicologia: Teoria e Prática*, 13 (1),75-88.
- Howell, A.J. (2009). Flourishing: Achievement-related correlates of students' wellbeing. *Journal of Positive Psychology*, 4(1), 1–13.
- Hu, S., and G. D. Kuh. 2002. “Being (Dis) Engaged in Educationally Purposeful Activities: The Influences of Student and Institutional Characteristics.” *Research in Higher Education* 43 (5): 555–575. doi:10.1023/A:1020114231387.

- 
- Kahu, E. R. (2013). Framing student engagement in higher education. *Studies in Higher Education*, 38(5), 758–773. doi:10.1080/03075079.2011.598505
- Kahu, E. R., Nelson, K. (2018). Student engagement in the educational interface: Understanding the mechanisms of student success. *Higher Education Research & Development*, 37(1), 58–71. <https://doi.org/10.1080/07294360.2017.1344197>
- Khademi Ashkzari, M., Piryaei, S., & Kamelifar, L. (2018). Designing a causal model for fostering academic engagement and verification of its effect on educational performance. *International Journal of Psychology*, 12(1), 032113
- Kuh G (2001) The national survey of student engagement: Conceptual framework and overview of psychometric properties. Indiana University Center for Postsecondary Research and Planning: [http://nsse.iub.edu/pdf/conceptual\\_framework\\_2003.pdf](http://nsse.iub.edu/pdf/conceptual_framework_2003.pdf) [accessed 17 September 2008].
- Law B (2005) Experiential learning in the context of educating for a sustainable future: Is it an appropriate pedagogy for shifting teachers' thinking and engaging learners? *Set* n. 3.
- Jones, B. D . (2010). An examination of motivation model components in face-to-face and online instruction. *Electronic Journal of Research in Educational Psychology*, 8(3), 915–944.
- Nauta, A., Vianen, A., Heijden, B., Dam, K., Willemsen, M. 2009. Understanding the factors that promote employability orientation: The moderating impact of employability culture. *Journal of Occupational & Organizational Psychology*. 82. 233-251. 10.1348/096317908X320147.
- Maroco, J. P., Maroco, A. L., Campos, J. A., & Fredricks, J. A. (2016). University Student's Engagement: Development of the University Student Engagement Inventory (USEI). *Psicologia: Reflexão e Crítica*, 29 , 1-12. doi: 10.1186/s41155-016-0042-8
- Mascarenhas, S., Polydoro, S. A. J., & Guerreiro-Casanova, D. C. (2013). Autoeficácia para a formação superior e rendimento académico de estudantes universitários. In Mascarenhas, S. A. N. (Coord.), *Determinantes do rendimento académico no ensino superior*. (pp. 164-181). São Paulo: Edições Loyola
- McMahon B and Portelli J (2004) Engagement for what? Beyond popular discourses of student engagement, *Leadership and Policy in Schools* 3(1): 59–76.
- Polydoro, S. A. J., Vieira, D., & Coimbra, J. L. 2008. Adaptação para a realidade portuguesa da Escala Autoeficácia na Formação Superior (AEFS). Comunicação apresentada no XIII Congresso de Avaliação Psicológica: Formas e contextos. Braga: Universidade do Minho, 2-4 Outubro de 2008
- Reeve, J., & Tseng, C. (2011). Agency as a fourth aspect of students' engagement during learning activities. *Contemporary Educational Psychology*, 36(4), 257–

- 
- Salanova, M., Schaufeli, W.B., Martínez, I., & Bresó, E. (2010). How obstacles and facilitators predict academic performance: The mediating role of study burnout and engagement. *Anxiety, Stress & Coping*, 23(1), 53–70.
- Schaufeli, W. B., Martinez, I., Marques-Pinto, A., Salanova, M., & Bakker, A. (2002a). Burnout and engagement in university students. *Journal of Cross-Cultural Psychology*, 33(5), 464–481.
- Schaufeli, W. B., Salanova, M., Gonzalez-Roma, V., & Bakker, A. (2002b). The measurement of engagement and burnout: A two sample confirmatory factor analytic approach. *Journal of Happiness Studies*, 3(1), 71–92.
- Schuetz P (2008) A theory-driven model of community college student engagement, *Community College Journal of Research and Practice* 32: 305–24.
- Shull, P.J., & Weiner, M.D. (2002). Thinking Inside the Box: Self-Efficacy of Women in Engineering. *International Journal of Engineering Education*, 18, 438-446.
- Schunk, D., & Gunn, T.P. (1986). Self-Efficacy and Skill Development: Influence of Task Strategies and Attributions. *Journal of Educational Research*, 79, 238-244.
- Schunk, D. H. 1989. Self-efficacy and achievement behaviors. *Educational Psychology Review*, 1, 173-208.
- Schunk, D. H. 1994. Self-regulation of self-efficacy and attributions in academic settings. In D. H. Schunk & B. J. Zimmerman (Eds.), *Self-regulation of learning and performance: Issues and educational applications* (pp. 75–99). Lawrence Erlbaum Associates, Inc.
- Schunk, D. H. (1995). Self-efficacy and education and instruction. In J. E. Maddux (Ed.), *Self-efficacy, adaptation and adjustment: Theory, research and application* (pp. 281–303). New York: Plenum Press.
- Schunk, D. H. (2003). Self-efficacy for reading and writing: Influence of modeling, goal setting and self-evaluation. *Reading and Writing Quarterly: Overcoming Learning Difficulties*, 19(2), 159–172.
- Trockel, M.T., Barnes, M.D., & Egget, D.L. (2000). Health-related variables and academic performance among first-year college students: Implications for sleep and other behaviors. *Journal of American College Health*, 49(3), 125–131.
- Ouweneel, E., Le Blanc, P.M., & Schaufeli, W.B. (2011). Flourishing students: A longitudinal study on positive emotions, personal resources, and study engagement. *Journal of Positive Psychology*, 6(2), 142–153, DOI: 10.1080/17439760.2011.558847.
- Pintrich, P. R., & Schunk, D. H. (1996). *Motivation in education: Theory, research and applications*. Englewood Cliffs, NJ: Prentice Hall Merrill

- 
- Vieira, D. A. (2010). Auto-eficácia na formação superior: Um factor protector face ao insucesso académico? In A.S. Pereira, H. Castanheira, A.C. Melo, A.I. Ferreira e P. Vagos (Eds.), *Apoio Psicológico no Ensino Superior: modelos e práticas* (pp.355-361). Aveiro: Universidade de Aveiro/RESAPES-AP.
- Vieira, D. A. (2012). Autoeficácia na formação superior e desempenho académico: Um estudo longitudinal. II Congresso Nacional da RESAPES-AP, *Apoio Psicológico na Ensino Superior: Um olhar sobre o futuro*. Porto: Instituto Superior de Contabilidade e Administração do Porto, 10-11 de maio.
- Vieira, DA; Polydoro, S., Guerreiro-Casanova, DC. (2017). Escala autoeficácia na formação superior (AEFS). Coord. Almeida, L. S., Simões, M. R., Gonçalves, M. M. 2017. *Adaptação, Desenvolvimento e Sucesso Académico dos Estudantes do Ensino Superior: Instrumentos de avaliação*. ADIPSIEDUC Edições. ISBN 978-989-99517-1-6
- Vogt, C. M. (2008). Faculty as a critical juncture in student retention and performance in engineering programs. *Journal of Engineering Education*, 97(1), 27-36.
- Wentzel, K. R. (2012). Socio-Cultural Contexts, Social Competence, and Engagement at School. In S. Christenson, A. Reschly, & C. Wylie (eds.), *Handbook of Research on Student Engagement*. (pp. 479-488). NY: Springer.
- Zimmerman, B. J. (2000). Attaining self-regulation: A social cognitive perspective. In M. Boekaerts, P. R. Pintrich, & M. Zeidner (Eds.), *Handbook of selfregulation* (pp. 13–35). San Diego, CA: Academic Press
- Zusho, A., Pintrich, P. R., & Coppola, B. (2003). Skill and Will: The Role of Motivation and Cognition in the Learning of College Chemistry. *International Journal of Science Education*, 25, 1081-1094.



# Health Promotion Conceptual Evolution and Program development: a Literature Review

José Félix<sup>1,2,3</sup> , Paula Clara Santos<sup>2,4,5</sup> , Pilar Baylina<sup>3,6,7</sup> 

<sup>1</sup> Department of Physics, School of Health of Porto, Polytechnic Institute of Porto, Rua Dr. António Bernardino de Almeida, 400, 4200 - 072, Porto, Portugal

<sup>2</sup> Research Center in Rehabilitation - Center for the Study of Movement and Human Activity, Rua Dr. António Bernardino de Almeida, 400, 4200 - 072, Porto, Portugal

{jmf, pcs}@ess.ipp.pt

<sup>3</sup> LaBMI - Laboratory of Medical and Industrial Biotechnology, Rua Arq Lobão Vital, 172, 4200-374 Porto, Portugal

pbm@ess.ipp.pt

<sup>4</sup> Department of Physiotherapy, School of Health of Porto, Polytechnic Institute of Porto; Rua Dr. António Bernardino de Almeida, 400, 4200 - 072, Porto, Portugal

<sup>5</sup> CIAFEL (Research Center in Physical Activity, health and Leisure), Faculty of Sports, University of Porto and Laboratory for Integrative and Translational Research in Population Health (ITR), Porto, Portugal

<sup>6</sup> Department of Health Management and Administration, School of Health of Porto, Porto Polytechnic Institute; Rua Dr. António Bernardino de Almeida, 400, 4200 - 072, Porto, Portugal

<sup>7</sup> Metabesity group, I3S – Institute for Research and Innovation in Health from University of Porto; Rua Rua Alfredo Allen 208, 4200-135 Porto, Portugal

**Abstract.** *The World Health Organization defends prevention and health promotion among communities as a driver of economic and social development, where the individual level of health literacy determines health choices such as adopting healthy lifestyles, managing individual healthcare and preventing*

*chronic diseases. Currently, health promotion is guided by a set of values, being these principles essential for identifying needs and priorities, planning, implementing, evaluating and determining the health promotion programs, that can be defined as a set of programmed, integrated and interrelated strategies and actions that aim to promote health, prevent risks, reduce years of life lost due to disability and increase quality of life. There are several models for planning health promotion programs, such as the Precede-Proceed Model, the Multivariate Approach to Community Health (MATCH) Model, the Mapped Intervention Model and the Social Marketing Model. A good planning of a health promotion program can effectively reduce the health costs.*

**Keywords.** Health promotion, health education, prevention, program development, health literacy



---

# 1 Prevention and Health Promotion

## 1.1 Origin and Evolution of health prevention and promotion

The World Health Organization defends prevention and health promotion among communities as a driver of economic and social development, through which it will be possible to improve the level of quality of life using this health method [1]–[6].

Health promotion corresponds to all processes and procedures that aim to improve, individually and in the community, essential capacities for the improvement of health conditions. It is a set of political and social guidelines aimed at the sustainable development of nations. To this end, health promotion is based on enabling individuals to identify, carry out and adapt actions that result in their integral well-being, making them endowed with a good level of health literacy. It is understood as a tool that enables the improvement of quality of life, focusing on the adaptation and implementation of healthier lifestyles. In the first instance, it aims to reduce the costs of treating pathologies, integrating it with primary prevention, being the first means of action in the community[1]–[3], [5]–[10].

Disease prevention has come to be understood not only as prevention but also as the reduction of risk factors inherent to the pathology. However, at the time of the onset of the disease, prevention can be understood as the reduction of the evolution of the consequences. When it comes to chronic diseases, priority is given not only to the prevention of risk factors but also to increase the average life expectancy, in years lived with a level of quality of life [11]–[15].

It is important to highlight that these concepts have evolved since the 1920s when health promotion was considered a concept of preventive medicine at that time. This was defined by some authors as the “effort” of society, in order to achieve policies to improve health conditions, as well as education for the improvement of individual health, aiming at the development of “social machinery” and ensuring all levels of living healthier [16]. Later, Henry Sigerist cited in [17], when presenting the four tasks of medicine, refers and presents for the first time the term health promotion. He considers that health is achieved when the living conditions of the individuals are adequate, indicating to the governments, unions and other sectoral leaders to join efforts to put into practice the perspective presented [16], [18]–[21].

After the Second World War (1939-1945) relationships between health behavior and disease prevention were demonstrated, with various levels of prevention; primary prevention (which aims to promote health and protection, increasing levels of health, centered individually and in the community, pointing to health education and motivation); secondary prevention (early diagnosis and treatment) and tertiary prevention (rehabilitation). In this way, disease prevention created the motto for health promotion, initially understood as a set of actions aimed at changing behaviors, taking into account the family, social and cultural environment [16], [18]–[21].

In 1945, with the creation of the WHO, health is accepted worldwide as a “fundamental and universal right for all”, which is why a major restructuring of concerns by countries with a view to health began. This is how investment in public policies and the creation of beneficial

environments for the development of individual and community capacities begin [16], [18]–[21].

Around 1970, the Canadian Minister of Health and Welfare, Marc Lalonde (1974) sees the diseases of the developed world as a consequence of human behavior, releasing the document “Inform Lalonde”. The work presents the costs of health models based on the medical approach to chronic diseases (focusing on determinants in health, human biology, genetics, lifestyle and health care organization)[21].

In 1977, in the Republic of Kazakhstan, in Alma-Ata, one of the most relevant meetings for health takes place, where the Alma-Ata Declaration is launched. Reiterates the creation of Primary Health Care (PHC), as well as the need for the involvement of the community and all social sectors in this new concept that is “health for all”[16], [18]–[20].

In 1986, in Ottawa, the Health Promotion Letter is adopted, which sets the tone for public health through the development of health promotion. In this letter, legal, egalitarian and mediation perspectives are presented for the prerequisites of public health and the definition of health promotion as the “process of empowering the community to act in the improvement of its quality of life and health, including a greater participation in this process”. It lists five action axes for health promotion, based on: construction of healthy public policies, creation of favorable environments for health, reinforcement of community action, training of individuals and reorientation of health services, creating the initial concept of health promotion [16], [18]–[20].

In the following years, several meetings and conferences were held to develop and implement the new concept of “health promotion” in order to respond to the guidelines and strategies set out in the Health Promotion Letter. In 1988, in Australia, the Adelaide Conference aimed to identify Healthy Public Policies. Defends the need for the involvement of all social sectors (industry, commerce, education and communication) for economic, social development and health promotion [16], [18]–[20].

In 1991, in Sweden, the Söndsvall Conference tried to create favorable environments for health, presenting the environment as a factor influencing health. It identifies four fundamental environments for health promotion: social environment (cultures and customs that influence health choices); political (with regard to governmental decisions related to health); economic (distribution of resources among different sectors according to importance and relevance, sustainably) and drawing on the knowledge and skills of women in all sectors [16], [18]–[20].

In 1997, the Jakarta Declaration attempted to respond to the challenges of health promotion in the 21<sup>st</sup> century by highlighting the importance of the community sector and surrounding local power in promoting health. The training of the individual was encouraged for a good management of resources, correct decision-making in health and definition of places that can be useful in the development and implementation of health promotion, namely cities, workplaces, health centers and other services, such as the private sector[16], [18]–[20].

In 2000, the 5<sup>th</sup> Global Conference on Health Promotion, in Mexico, with the theme “Towards Greater Equity”, originated the Ministerial Declaration of Mexico for Health Promotion. The primary strategy in health policies and plans, ensure active participation of

all social sectors, creation of National Plans for Health Promotion and support for research that develops knowledge on priority areas [16], [18]–[20].

In 2005, in the Bangkok Declaration, in addition to reaffirming previously launched perspectives, it presents promotion as a method for individuals to improve control over their health, pointing out strategies for including health promotion in the globalization agenda [16], [18], [20].

In 2009, in Nairobi, the Global Conference on Health Promotion was held, based on the theme “Closing the chasm in the implementation of Health Promotion”, identifying health promotion as a tool for reducing inequalities in health and in the economic level. It highlights the potential of health promotion as a tool to revitalize PHC, resorting to health promotion in the globalization agenda and creating action plans adjusted and designed according to observed, felt and evaluated needs in a more cost-effective manner. Multiple strategies were presented, such as: training for health promotion, leadership training and improvement of management performance, strengthening of health promotion in services, health care throughout the entire life cycle, existence of beneficial partnerships between sectors in order to create policies for the implementation and construction of better evidence and community empowerment through capacity building and increasing health literacy [16], [18]–[20], [22].

During 2013, in Helsinki, a conference was held on the theme “Health in All Policies”, where the impact of public policies in all sectors that influence health decisions is addressed. It is defined that health is one of the fundamental human rights, being the government and the community responsible for equity, which is an expression of social justice. This conference resulted in the following strategies: political priority for equity in health, acting according to the social determinants of health, existence of resources and infrastructure for the implementation of health, strengthening ministries of health to involve other ministries in health decisions (creation of partnerships), promote the capacity to implement health and evidence on its determinants, carry out audits in health processes, and consequent accountability towards results, increase trust between governments and societies, eradicate conflicts of commercial interests and increase the development, implementation and monitoring of health using health literacy [16], [18]–[20], [22].

In 2016, in the city of Shanghai takes place the Conference with the theme “Health promotion in the objective of sustainable development: Health for all and all for Health”. This conference highlights the contributions of health promotion to improving it, reinforcing the impact of health promotion on sustainable development, as well as the presentation of three key concepts for health promotion: “good governance”, “healthy cities” and “health literacy”. The Shanghai Declaration, addressed to the governments of all nations, is focused on health promotion and indicates twenty “steps” organized around three major areas: “1- Transformation of political orientation; 2- Transform the way of acting; 3- Build capacity for adaptive government” [1]–[6], [21].

It is known that this concept of health promotion is not yet fully implemented worldwide, as well as in all community sectors. However, it is a fundamental strategy in the creation of good levels of health literacy, which will be reflected in choices that can create and develop situations that prevent disease and promote better levels of health. Health becomes an

essential good, related to disease prevention, with a migration from the pathogenic model to the salutogenic model, creator of the concept of health promotion [16], [18].

The individual level of health literacy determines health choices such as adopting healthy lifestyles, managing individual healthcare and preventing chronic diseases. In turn, they directly and indirectly influence health costs and, consequently, the sustainability of the national health system [3], [4], [14], [15], [23]–[26].

## **1.2 The promotion and education in health**

Health promotion has a strong relationship with health education [27]. Health education promotes a wide range of experiences that facilitate the determination of conducive health actions. In this way, it allows individuals new knowledge, attitudes and skills that promote an improvement in the state/level of health. In order to implement these teaching and training methodologies, individual, collective or interactive actions can be carried out, using technological means, achieving behavioral changes, as a result of oral communications, public announcements, webinars, social marketing techniques, private messages or blogs [27].

Nowadays, health promotion can be seen through two perspectives: health education and environmental actions. Health education uses individual and collective strategies in order to be able to observe behavioral changes and the empowerment of individuals. Environmental actions propose strategies applied at political, social, economic, governmental, legal and organizational levels. As a commitment to corporate social responsibility, these types of actions aim at the empowerment of individuals and community for health promotion and increased investment in health by all sectors [27]–[30].

Currently, health promotion is guided by a set of values based on the ecological perspective of health, which has the cultural, economic and social dimension of health determinants, commitment to equality, justice, respect for diversity, sustainability and social participation. These principles are essential for identifying needs and priorities, planning, implementing, evaluating and determining the reliability of solutions for health promotion. [27]–[30].

The Health Development Model (HDM) prioritizes the prevention of risk factors, health promotion and the optimization of individual health development through training for the individual's own health. The perspectives are not only the onset of the disease and the establishment of risk factors, but also the improvement of the quality of life in the long term. It is evident that the realization of health promotion through effective tools and easy access to the whole community, aimed at learning the concepts and essential factors in maintaining a healthy and an adequate lifestyle [27]–[30].

## **1.3 Health promotion implementation programs**

A health promotion program can be defined as a set of programmed, integrated and interrelated strategies and actions that aim to promote health, prevent risks, reduce years of life lost due to disability and increase quality of life [31].

Currently, places where health promotion programs are carried out, such as in the community, health service organizations, workplaces and schools, requiring the creation of programs with strategies and implementation actions. It is essential to have planning, general and specific objectives, evaluation indicators, action strategies and directives that constitute this plan. Studies indicate that a well-planned and implemented programs can promote a return of about \$1.88 to \$3.92 for every dollar invested, which leads to lower health costs [27], [32], [33].

Health promotion has been focusing on literacy, through patient empowerment, learning to control and obtain gains in their own health, qualifying health management and cost rationalization. In order to support the program's methodology, theoretical approaches are needed. For this purpose, there are currently several theoretical levels to be taken into account in the construction of programs, such as: intrapersonal level, interpersonal level and community level [27], [31], [32], [34], [35].

The intrapersonal level relies on approaches such as the model of health beliefs - taking into account the individual's beliefs and their influence on health choices; the theory of planned behavior and the theory of rational action - which defend that the behavior of individuals will be dependent on the perception of norms, attitudes and behavior control - and, finally, by the trans-theoretical model and stages of change - presents the stages of behavior change such as pre-contemplation (initiates change thinking throughout 6 months), preparation (starts preparing the change, 1 month), action (change that lasts 6 months) and maintenance (contains the behavior for 6 months to 5 years) [27], [35].

The interpersonal level investigates the theory of social cognition - defines that human behavior is based on the reciprocal determinism between the environment and the individual; the theory of social support and social network - defends the impact of social relationships and networking on mental and physical health [27], [35].

The community level, where the theory of communication is found, emphasizes the power of the media in transmitting a message and producing it. Innovative dissemination models emphasize the use of innovative marketing techniques for the dissemination of messages, and, finally, community mobilization encourages organized activities to verify changes in health outcome [27], [35].

Nevertheless, there are approaches to program design, such as: behavior and lifestyle change, environmental restructuring and development, and a socio-ecological approach [27], [35]

Changing behaviors and lifestyles - an approach that advocates that the programs should focus on disease prevention, replacing unhealthy behavioral patterns (which contribute to the increase in risk factors) with healthy behaviors and habits. This change has been studied and factors that influence it can be pointed out. Social factors, as they shape the way individuals act, choose between options and feel about their health and life. The theory of social influence points out three basic forms of influence: cognitive changes resulting from changes in opinion and beliefs, affective changes and behavioral changes towards those around them [27], [35].

On the other hand, attention should be paid to environmental restructuring and development, where it is considered that the physical environment surrounding individuals

needs to be changed in order to reduce or eradicate toxic or pathological elements leading to pathologies. The geographic, architectural and technological structure are structures that can lead to pathogenic transmission (noise, pollution and social conflicts). This environment can serve as an example for individuals, as well as a provider of quality services that enable them to “promote” their health. As for the environment, issues such as health, industrial and occupational hygiene, environmental health and environmental psychology must be taken into account. Models that take this aspect into account can become more comprehensive, as they can encompass all individuals in a society [27], [35].

Finally, the socio-ecological approach is not based on a perspective, but on a whole paradigm. Here, ecological concerns the study of the interrelationship between the organisms involved in an environment. The physical, social and cultural dimensions, as well as genetic, psychological factors and behavior patterns are considered variables. These influence various outcomes such as physical and emotional well-being and social cohesion and maturation. Thus, this strand emphasizes and prioritizes the interdependence and relationship of the environment with all individual factors [27], [35].

In Fig. 1, some general aspects of each of the approaches are presented [35].

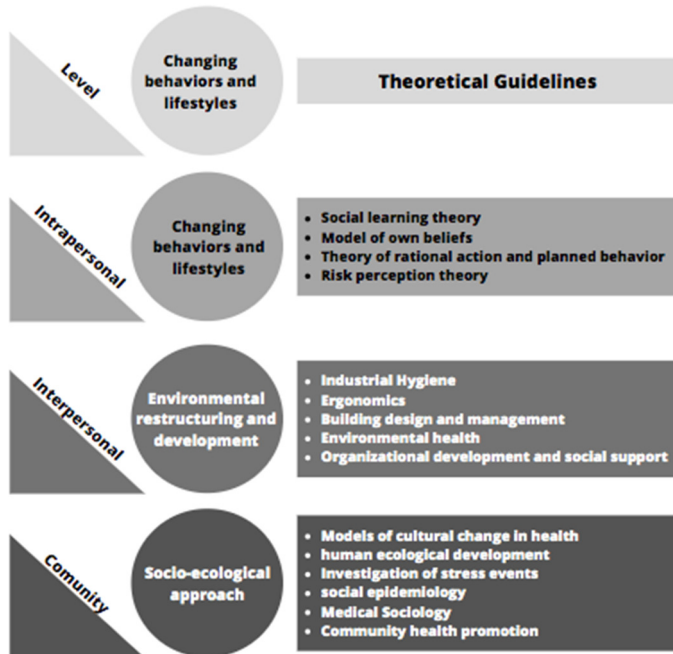

**Figure 1.** General aspects of approaches

It is also important to understand that each of the approaches will have different health determinants as well as different promotion focuses, and different types of interventions highlighted Fig. 2 [27], [28], [35].

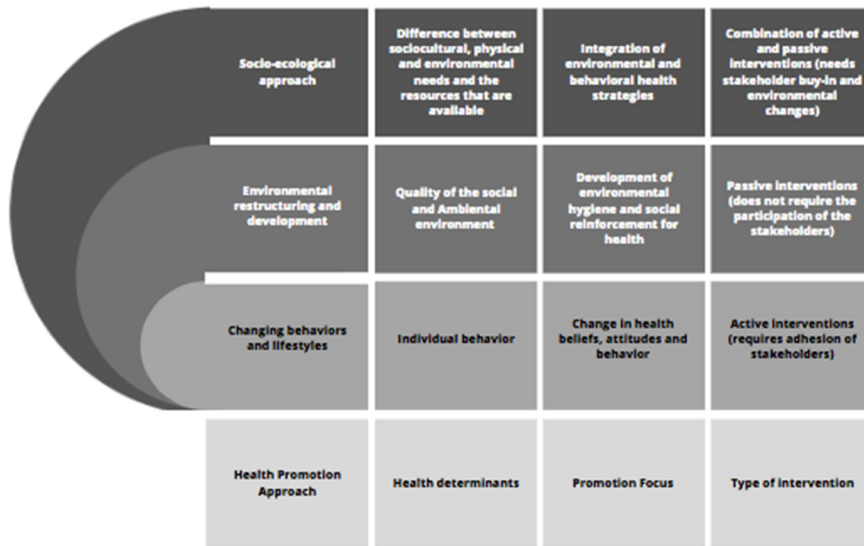

**Figure 2.** Health determinants, focus and types of intervention according to the approach of health promotion programs

According to the socio-ecological approach, it is necessary to identify various physical and environmental conditions that influence the physical, psycho-emotional and social well-being of individuals. Through a multivariate evaluation it is possible to take into account some principles in the design of health promotion programs. The influence of intrapersonal and environmental conditions on individual and community well-being, such as the development of programs that suit the environment and individuals and, finally, that focus health promotion interventions on behavioral and organizational aspects of great impact. The design of health promotion programs that integrate interdependencies between the physical, social, life domains and multidisciplinary perspectives that use different methods to measure the scientific and social validity of different interventions[27], [35].

The construction of a health program, in addition to presenting all the care, levels and approaches previously detailed, must precede a diagnosis of needs achieved through a demographic diagnosis. This can be done through a questionnaire, which easily determines the risk factors. However, the program can also be carried out taking into account an age group or life stages (such as adolescence, young adults, menopause, among others) or predisposition to risk factors [27], [35], [36].

**1.4 Steps in building a health promotion program:**

For the construction of a health promotion programs there are three essential steps: planning (diagnosis, prioritization of problems), implementation and evaluation [27], [35], [36].

There are several models for planning health promotion programs, such as the Precede-Proceed Model, the Multivariate Approach to Community Health (MATCH) Model, the

Mapped Intervention Model, the Community Preparedness Model and the Social Marketing Model [27], [37].

The Precede-Proceed Model (Predisposing, Reinforcing and Enabling Constructs in Educational/Ecological Diagnosis and Evaluation and Policy, Regulatory and Organizational Constructs in Educational and Environmental Development) consists of eight phases divided into four initial phases of Precede and four final phases concerning to Proceed. In Precede, the first phase concerns social assessment, in the sense of identifying the level of quality of life through various indicators that influence health. The second phase corresponds to an epidemiological assessment, which makes it possible to identify which health problem reduces the quality of life. In a third phase, an ecological and educational evaluation is carried out and, in the final phase, an administrative and political evaluation and the alignment of the intervention are carried out. In Proceed, phase five refers to program implementation, phase six to evaluation, phase seven to the impact of the evaluation and, conclusively, phase eight presents the results of the evaluation [27], [37].

The MATCH Model consists of five phases, subdivided into multiple steps. The first phase corresponds to the identification of the target, using a social assessment in health and epidemiology. The second phase concerns the planning of the intervention through the identification of objectives, approach and strategy. In stage three, the program is developed with a detailed description of all aspects and, in stage four, preparation for implementation. This step includes training professionals and overcoming legal and political issues. In the last and fifth phase, the evaluation of the program planned so far is carried out [27], [37].

In the Mapped Intervention Model, needs are assessed, an evidence-based program is created and its implementation planned. The Community Preparedness Model assesses community tolerance, denial, resistance and plans the program within that variant. Finally, the Social Marketing Model is based on the marketing-mix plan [27], [37].

It is essential to plan the structure of the program and some steps of the planning process can be defined, as presented in Fig. 3 [27], [37].



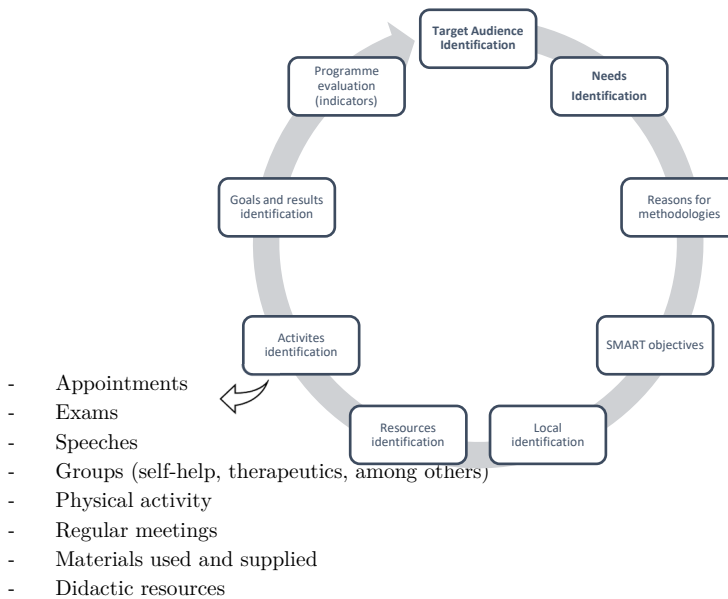

**Figure 3.** Planing Process [27], [37].

During the planning and management of health promotion programs, collective factors, as well as intrapersonal factors of the participants, must be taken into account, which are extremely relevant for their effectiveness. In this sense, aspects such as the individual monitoring of participants by the health system, overlapping of drug and unconventional therapies, such as the implementation of treatments without scientific evidence [27], [31].

On the other hand, it must be considered that a fundamental aspect of the program involves the motivation for adherence, allowing these participants to improve their health levels, benefiting their families, since the participant can become active in the workplace, the which reduces economic dependence. Health providers also benefit from the individual's participation in these programs. By not needing to go to the services, or being the recipient of certain health care, there is a reduction in national health expenditures [24], [28].

The construction of health promotion programs involves the identification of relevant aspects that are good intermediaries in the implementation of interventions, the combination of individual and environmental factors and the measurement of the sustainability of the program and its results. The ecological vision allows establishing fundamental constructs in the design of health promotion programs, aimed at maximizing the benefits for health, economy and society [27], [35], [37].

Table 1 presents a summary of strategies, approaches and theories used in planning health promotion programs [27].

**Table 1.** Strategy and levels of action and useful theories [27] .

<b>Approach</b>	<b>Strategies</b>	<b>Level of Performance</b>	<b>Useful Theories</b>
<b>Changing behaviors and lifestyles</b>	Educational sessions;	Individual (intrapersonal)	Health Belief Model
	Brochures		Theory of Planned Behavior and Rational Action
	Social marketing campaigns		Trans-theoretical Model
<b>Environmental restructuring and development</b>	Mentoring Programs;	Interpersonal	Cognition social Theory
	Definition of objectives;		Social support and social networking theory
	Increase in social networking;		
<b>Socio-ecological approach</b>	New organizational policies;	Community	Communication theory
	Media campaign;		Diffusion of Innovative Models
	Change in public policies		Community Mobilization

### 1.5 Economic impact of health promotion programs

Currently, there is a wide variety of ways to indicate and evaluate costs and economic variables related to health promotion programs [33]. Recent studies indicate that the organization of health promotion programs may have a Return-on-Investment rate of 3.27\$, and will provoke a rate of 2.73\$ for absenteeism [33]. It is indicated that, when compared to conventional treatment, these programs end up being less cost-effective. We can conclude, based on these data, that prevention and health promotion can generate high levels of quality in health at a reduced cost [38].

One of the most relevant aspects to be indicated by the implementation of health promotion programs is the reduction of the use of consultation and the consequent reduction of costs. However, there may be an increase in health costs if users resort to complementary means of diagnosis, as they become more “active” in their own health, carrying out early screening [39].

As mentioned earlier, one of the major axes developed in health promotion programs is health literacy. This concept directly influences the level of acuity in their lifelong decisions and health choices. In view of this, the higher the level of health literacy is, better the health choices, removal of risk factors, understanding of health information and, consequently, the lower the expenditure on treatment of disease(s) or hospitalizations [40].

Program planning requires various resources, from human, material and financial. All materials needed throughout the program, human resources and the cost associated with its intervention must be accounted for, as well as all the financial investment necessary for its implementation. A study developed by Hatziandreu, et al (1988) [41] accounts for the direct and indirect costs of a health promotion program using physical activity (PA). In direct costs, all materials used for the practice of PA are considered, while in indirect costs, the monetary units lost for the time spent in the practice of PA are accounted for. The costs of the professionals who carried out the follow-up of the participants are also added. As a result, the authors indicate that PA, when used as a tool for health promotion, can present a cost of

around 12,500\$ for each QALY (quality-adjusted life year) while the treatment of chronic diseases such as coronary heart disease can be around \$40,000 for each QALY [41], [42]

An example is the implementation of a health promotion program for chronically ill patients in São Paulo, which managed to reduce health costs by 47.12% compared to previous years [42].

## 2 Conclusions

Developing a health promotion program is composed of several steps that can be extended over an extensive period of evaluation, to the phase of identification of needs, construction of objectives and finally programming and implementation of the program.

Today, there are several models on which health managers and professionals can base themselves to develop a specific and sensitive program, from the MATCH model to the Precede-Proceed model. All programs aim an assessment of needs to determine the objectives, through which it will be possible to structure objectives and indicators, plan activities to achieve the objectives. The program management component will always aim at an economist view of the program, reducing costs both in its implementation and in the late treatment of risky health behaviors.

The health promotion programs, aimed at reducing risks, promote healthy habits and reduce comorbidities, thus allowing cost reduction for both the patient and the health system.

Based on the exposed, it is possible to conclude that a program requires a wide range of evaluation tasks in order to be able to develop a specific and viable program, with a view to achieving objectives, reducing costs and promoting behavioral changes that are reflected in a better self-management in health.

## References

- [1] World Health Organization, “Declaration of Alma-Ata International,” *World Health Organization*, no. 1995, p. 662, 2000.
- [2] A. Carvalho, “Promoção da saúde: concepções, valores e práticas de estudantes de enfermagem e de outros cursos do ensino superior,” 2007.
- [3] R. E. Glasgow, L. M. Klesges, D. A. Dzewaltowski, P. A. Estabrooks, and T. M. Vogt, “Evaluating the impact of health promotion programs: Using the RE-AIM framework to form summary measures for decision making involving complex issues,” *Health Educ Res*, vol. 21, no. 5, pp. 688–694, 2006, doi: 10.1093/her/cyl081.
- [4] J. P. Janini, D. Bessler, and A. B. de Vargas, “Educação em saúde e promoção da saúde: impacto na qualidade de vida do idoso,” *Saúde em Debate*, vol. 39, no. 105, pp. 480–490, 2015, doi: 10.1590/0103-110420151050002015.

- [5] World Health Organization, "Promoting Health: Guide to National Implementation of the Shanghai Declaration," *9th Global Conference on Health Promotion: Shanghai 21-24 November 2016*, pp. 1–35, 2018.
- [6] World Health Organization, "More active people for a healthier world: global action plan on physical activity 2018-2030," 2018, [Online]. Available: <https://apps.who.int/iris/bitstream/handle/10665/272722/9789241514187-eng.pdf?ua=1>
- [7] R. Z. Goetzel and R. J. Ozminkowski, "The health and cost benefits of work site health-promotion programs," *Annu Rev Public Health*, vol. 29, pp. 303–323, 2008, doi: 10.1146/annurev.publhealth.29.020907.090930.
- [8] K. R. Pelletier, "A review and analysis of the health and cost-effective outcome studies of comprehensive health promotion and disease prevention programs at the worksite: 1993-1995 Update," *American Journal of Health Promotion*, vol. 10, no. 5, pp. 380–388, 1996, doi: 10.4278/0890-1171-10.5.380.
- [9] P. M. Buss, "Promoção da saúde e qualidade de vida," *Cien Saude Colet*, vol. 5, no. 1, pp. 163–177, 2000, doi: 10.1590/s1413-81232000000100014.
- [10] R. Mendes *et al.*, "Physical activity promotion tools in the portuguese primary health care: An implementation research," *Int J Environ Res Public Health*, vol. 17, no. 3, pp. 1–11, 2020, doi: 10.3390/ijerph17030815.
- [11] World Health Organization, "Ottawa Charter for Health Promotion," vol. 290, no. 6, p. 48, 1986, doi: 10.1038/scientificamerican0604-48.
- [12] Ottawa, "Carta de Ottawa, Promoção da saúde nos países industrializados," *Conferência Internacional Sobre Promoção da Saúde*, vol. 1, no. 1, pp. 1–9, 1986.
- [13] D. Nutbeam and I. Kickbusch, "Health promotion glossary," *Health Promot Int*, vol. 13, no. 4, pp. 349–364, 1998, doi: 10.1093/heapro/13.4.349.
- [14] J. Fries, L. Sandvik, J. Erikssen, E. Thaulow, and G. Erikssen, "Reducing Health Care Costs by Reducing the Need and Demand for Medical Services," *N Engl J Med*, vol. 328(8), pp. 2010–2013, 1993.
- [15] J. Fries, H. Harrington, R. Edwards, L. Kent, and N. Richardson, "Randomized Controlled Trial of Cost Reductions from a Health Education Program: The California Public Employees' Retirement System (PERS) Study," *Nancy Richardson is National*, pp. 216–223, 1994.
- [16] M. Martins, "A Promoção da saúde: percursos e paradigma," 2005.
- [17] P. Buss, "Uma introdução ao conceito de promoção de saúde.," in *Promoção da saúde: Conceitos, reflexões, tendências*, Fiocruz., D. Czeresnia and C. Freitas, Eds. Rio de Janeiro, 2012.

- 
- [18] I. T. S. B. Heidmann, M. C. P. de Almeida, A. E. Boehs, A. de M. Wosny, and M. Monticelli, “Promoção à saúde: trajetória histórica de suas concepções,” *Texto & Contexto - Enfermagem*, vol. 15, no. 2, pp. 352–358, 2006, doi: 10.1590/s0104-07072006000200021.
- [19] M. S. V. Lopes, K. R. O. Saraiva, and R. B. Ximenes, “Análise Do Conceito De Promoção Da Saúde,” *Análise do conceito de promoção da saúde*, vol. 19, no. 3, pp. 461–8, 2010.
- [20] A. B. Xavier, “As Cartas das Conferências Internacionais sobre Promoção da Saúde: uma análise das tendências ideo-políticas,” *7º Seminário frente nacional contra a privatização da saúde: Saúde em Tempos de Retrocessos e Retirada de Direitos*, 2017.
- [21] M. C. Faria, “As conferências internacionais sobre promoção da saúde – a passagem à ação,” 2020, pp. 135–144.
- [22] L. Graça, *Promoção da saúde: Uma abordagem positiva da saúde*, vol. I. 2015.
- [23] World Health Organization, “Health Promotion,” *World Health Organization*, 2020.
- [24] L. Hersh, B. Salzam, and D. Snyderman, “Health literacy in primary care practice,” *Am Fam Physician*, vol. 92, no. 2, pp. 118–124, 2015, [Online]. Available: <http://www.embase.com/search/results?subaction=viewrecord&from=export&id=L605246200>
- [25] I. Gatulytė, V. Verdiņa, Z. Vārpiņa, and Á. Lublőy, “Level of health literacy in Latvia and Lithuania: a population-based study,” *Archives of Public Health*, vol. 80, no. 1, Dec. 2022, doi: 10.1186/s13690-022-00886-3.
- [26] A. Barańska and A. Kłak, “Recent Trends in Health Literacy Research, Health Status of the Population and Disease Prevention: An Editorial,” *International journal of environmental research and public health*, vol. 19, no. 14. NLM (Medline), Jul. 01, 2022. doi: 10.3390/ijerph19148436.
- [27] C. I. Fertman and D. D. Allensworth, *Health promotion programs - From Theory to Practice*, vol. 75, no. 9. 2010.
- [28] N. Halfon, K. Larson, M. Lu, E. Tullis, and S. Russ, “Lifecourse health development: Past, present and future,” *Matern Child Health J*, vol. 18, no. 2, pp. 344–365, 2014, doi: 10.1007/s10995-013-1346-2.
- [29] H. I. Sarsak, “Telerehabilitation services: A successful paradigm for occupational therapy clinical services?,” *International Physical Medicine & Rehabilitation Journal*, vol. 5, no. Figure 3, pp. 93–98, 2020, doi: 10.15406/ipmrj.2020.05.00237.
- [30] I. B. Wilson and D. Paul, “Health-Related Quality of Life,” *JAMA*, vol. 273, 1995.
- [31] Agência Nacional de Saúde Suplementar, *Cartilha para a Modelagem de Programas para a Promoção da Saúde e Prevenção de Riscos e Doenças*. Rio de Janeiro, 2011.

- [32] D. D. Inman, K. M. van Bakergem, A. C. Larosa, and D. R. Garr, "Evidence-based health promotion programs for schools and communities," *Am J Prev Med*, vol. 40, no. 2, pp. 207–219, 2011, doi: 10.1016/j.amepre.2010.10.031.
- [33] L. S. Chapman, "Meta-Evaluation of Worksite Health Promotion Economic Return Studies: 2012 Update," *American Journal of Health Promotion*, vol. 26, no. 4, pp. 1–12, 2012, doi: 10.4278/ajhp.26.4.tahp.
- [34] L. Povlsen and I. Borup, "Health Promotion: A developing focus area over the years," *Scand J Public Health*, vol. 43, no. December 2014, pp. 46–50, 2015, doi: 10.1177/1403494814568595.
- [35] D. Stokols, "Translating Social Ecological Theory Into," *American Journal of Health Promotion*, vol. 10, no. 4, pp. 282–298, 1996.
- [36] Agência Nacional de Saúde Suplementar, "Manual técnico de promoção da saúde e prevenção de riscos e doenças na saúde suplementar," *American Heart Association*, p. 36, 2015.
- [37] I. da S. Brito, "Intervenção de Conscientização para Prevenção da Brucelose em Área Endêmica," Instituto de Ciências Biomédicas Abel Salazar da Universidade do Porto, 2008.
- [38] G. Müller, M. Pfänder, C. Schmahl, M. Bohus, and L. Lyssenko, "Cost-effectiveness of a mindfulness-based mental health promotion program: Economic evaluation of a nonrandomized controlled trial with propensity score matching," *BMC Public Health*, vol. 19, no. 1, pp. 1–12, 2019, doi: 10.1186/s12889-019-7585-4.
- [39] D. C. Alves, M. A. D. Ugá, and M. C. Portela, "Promoção da saúde, prevenção de doenças e utilização de serviços: avaliação das ações de uma operadora de plano de saúde brasileira," *Cad Saude Colet*, vol. 24, no. 2, pp. 153–161, 2016, doi: 10.1590/1414-462x201600020199.
- [40] M. da L. Antunes, "A literacia em saúde: investimento na promoção da saúde e na racionalização de custos," *As Bibliotecas da Saúde: Que Futuro? Actas das XI Jornadas APDIS*. pp. 123–33, 2014.
- [41] E. I. Hatziaandreu, J. P. Koplan, M. C. Weinstein, C. J. Caspersen, and K. E. Warner, "A cost-effectiveness analysis of exercise as a health promotion activity," *Am J Public Health*, vol. 78, no. 11, pp. 1417–1421, 1988, doi: 10.2105/AJPH.78.11.1417.
- [42] F. B. Onofrio and P. Alegre, "Ações de Promoção de Saúde e Prevenção de Doenças adotadas por operadoras com maior Índice de Desempenho na Saúde Suplementar (IDSS)," 2007.

# Ketamine Antidepressant Properties: a Systematic Review of Clinical Trials

Diogo Ferreira<sup>1</sup>, Agostinho Cruz<sup>2</sup>, Marlene Santos<sup>3</sup>

<sup>1</sup> Wells, SONAE MC  
diogo19951918@hotmail.com

<sup>2</sup> CISA – Centro de Investigação em Saúde e Ambiente, Escola Superior de Saúde – Instituto Politécnico do Porto  
agostinhocruz@ess.ipp.pt

<sup>3</sup> CISA – Centro de Investigação em Saúde e Ambiente, Escola Superior de Saúde – Instituto Politécnico do Porto; Centro de Investigação - Instituto Português de Oncologia do Porto  
mes@ess.ipp.pt

**Abstract.** *Ketamine has been used to provide a rapid and persistent antidepressant effect in patients with treatment-resistant depression. This drug reverses depressive symptoms by blocking N-methyl-D-Aspartate receptors, which causes a downstream effect on glutamatergic system. The main goal of this work consisted in a systematic review of the antidepressant and adverse events of Ketamine in patients with treatment-resistant depression. Keywords were defined with PICO's strategy and systematic review was performed by using the PUBMED database. After inclusion and exclusion criteria, a total of 21 articles were included. Results showed a rapid antidepressant action from the resynchronization of neural circuits upon Ketamine use. However, this drug was also associated with several induced side-effects, including changes in blood pressure, dissociative symptoms, headache, nausea and vomits. Different routes of administration and ketamine metabolites may be used to help to overcome some of the induced side-effects.*

**Keywords.** Major depressive disorder, treatment-resistant depression, electroconvulsive therapy, ketamine, antidepressant

# 1 Introduction

## 1.1 Depressive disorders

Depressive disorders, such as major depressive disorder (MDD), are among the most disabling illnesses in the world, with a considerable significant burden and morbidity, including the Disability-Adjusted Life Years (DALY) [1]. According to the Diagnostic and Statistical Manual of Mental Disorders, Fifth Edition (DSM-5), the diagnosis of a Major Depression Episode (MDE) requires five or more symptoms to be present within a 2-week period [2]. One of should include either depressed mood or anhedonia. The secondary symptoms of MDE are appetite or weight changes, sleep disturbances, psychomotor retardation or agitation, fatigue or loss of energy, reduced ability to think or concentrate, feelings of worthlessness or guilt, and thought or attempt to suicide [2]. Depressive disorders' prevalence and incidence have risen in recent years, with a lifetime prevalence of MDD estimated to be around 10% [3].

## 1.2 Molecular mechanisms of depression

The precise etiology of depression continues to be fully understood, despite the plethora of research describing the neuroanatomical, neuroendocrinological, and neurophysiological changes in depression [2], [4]. Multiple theories have been proposed to explain the molecular mechanisms behind depression, which is recognized to be a complex disease and most likely to develop as a result of hereditary and environmental variables [5]. The main mechanisms include the monoamine hypothesis, the HPA axis hyperactivity hypothesis, the neurotrophic hypothesis, the inflammatory hypothesis, and the glutamatergic hypothesis of depression [6].

The classic theory is the monoamine hypothesis of depression [7], and according, depression is the result of monoamine neurotransmitters (e.g. serotonin and/or norepinephrine and/or dopamine) depletion [7], [8]. Other theory is the hyperactivity of the HPA axis, in which depression is an endocrinological and stress illness, and is linked to the dysregulated levels of free T4, TSH, CRH, arginine vasopressin, corticotropin, corticosteroid release, and ACTH [9]. Regarding the neurotrophic hypothesis depression is associated with the loss of neurotrophic support and that effective antidepressant therapies increase neurogenesis and synaptic connectivity in cortical areas such as the hippocampus [10]. Brain-derived neurotrophic factor (BDNF) is thought to exert its influence on neuronal survival and growth effects by activating the tyrosine kinase receptor B (TrkB) in both neurons and glia [11]. On the inflammatory hypothesis, chronic exposure to elevated levels of inflammatory cytokines can lead to neuropsychiatric disorders, including depression [12]. Mechanisms of cytokine behavioral effects involve activation of inflammatory signaling pathways in the brain, as well as dysregulated inflammatory markers, that results in changes in monoamine, glutamate, and neuropeptide systems, and decreases in growth factors [13]. One of the most recent hypotheses of the depression relays on the glutamatergic system. The glutamatergic system is one of the more recent theories for depression [14]. Accordingly, changes in GABA, AMPA, EAAT, NMDA, and metabotropic glutamate receptors (mGluR1 through mGluR8) are associated



---

with depression, and fast-acting antidepressants like ketamine and esketamine have been shown to have an immediate neuroprotective and antidepressant effect [4],[15].

### 1.3 Treatment-resistant depression and ketamine

Despite the number of antidepressants available, only approximately two thirds of patients benefit from the currently prescribed antidepressant drugs. Patients who have already failed to improve following two or more trials of antidepressant treatments at sufficient doses and duration have significantly lower response rates, and display what is known as Treatment-resistant depression (TRD) [16]. As a result, patients undergo useless treatments for long periods of time, without displaying any favorable outcome. Furthermore, antidepressants that target the monoaminergic system usually take 6–12 weeks to act and reverse depressive symptoms. More effective and fast-acting antidepressants are clearly needed [3].

New therapeutic approaches have been targeting these concerns. Glutamatergic pathways have been associated with a robust novel antidepressant target, particularly for those with TRD, who are less probable to benefit from other monoaminergic treatments [17].

Several clinical trials had demonstrated that ketamine would be a suitable strategy to suppress the acute symptoms of depression due to its quick and long-lasting effect. Authors approved the clinical benefit of this drug when given an off-label use (subanesthetic dosage) [18]. Ketamine has shown antidepressant effects in patients with major depressive disorder (MDD) resistant to first-line treatments and approved for use in this patient population.

### 1.4 Ketamine mechanism of action

Ketamine induces several forms of synaptic plasticity, which are proposed to underlie its antidepressant effects [16]. The putative mechanism of action of ketamine consists in inhibiting, in a competitive way, the glutamate receptors, however the molecular mechanism of action directly responsible for ketamine's antidepressant effects remains under active investigation [19]. It may include pre-synaptic excitation/inhibition of glutamatergic neurons, reduction of the glutamate release, activation of AMPA ( $\alpha$ -amino-3-hydroxy-5-methyl-4-isoxazole propionic acid), NMDA receptor antagonism, post-synaptic activation of Brain-Derived Neurotrophic Factor (BDNF), targeting mTOR pathway, and the recovery of synaptic connectivity in PFC (Pre-Frontal Cortex) [18]–[20]. It was recently demonstrated that the effectors of the mammalian target of rapamycin complex 1 (mTORC1) signaling pathway, namely, eukaryotic initiation factor 4E (eIF4E) binding proteins 1 and 2 (4E-BP1 and 4E-BP2), are central in mediating ketamine-induced synaptic plasticity and behavioral antidepressant-like effect [21], [22].

### 1.5 Ketamine use and adverse reactions

Ketamine is known to have several therapeutic applications such as anesthesia, neuropathic pain, or associated with other drugs in various conditions [16]. Ketamine adverse reactions include changes in blood pressure, dissociative symptoms, headache, nausea and vomits.

However, drug-drug interactions are possible [23]. Opioid, benzodiazepines or even alcohol are some of the examples in which the association of ketamine was reported to have an impact on patients' health, namely changes in intraocular pressure, convulsions, and renal or hepatic problems [23]. Simultaneously, in individuals with an high risk of stroke or with previous allergy to ketamine, its use should be carefully evaluated [23].

The aim of this paper is to provide a systematic analysis about the antidepressant and adverse reactions of Ketamine in TRD patients.

## 2 Methodology

### 2.1 Data sources and search strategy

*PICO* strategy was defined to structure the algorithm: defining the Population (adult people with treatment-resistant depression), Intervention (use of Ketamine to eliminate Depression), Comparison with the intervention (Electroconvulsive therapy) and Outcome (rapid and robust antidepressant effects).

The PUBMED database was selected to obtain the articles for this review. Once inserted the keywords, synonyms (*Mesh* platform) and Boolean operators the search algorithm result was (*("ketamine" OR "cetamine") AND ("adverse events" OR "side-effects" OR "pain" OR "chronic pain" OR "symptoms" OR "symptomatology" OR "adverse drug reactions" OR "medication adverse reactions") AND ("effects" OR "efficacy" OR "response" OR "success therapy" OR "success treatment" OR "treatment" OR "therapy" OR "medical" OR "clinical" OR "clinical practice") AND ("apathy" OR "depression" OR "major depressive disorder" OR "refractory depression" OR "resistant depressant" OR "major disorder"))*).

### 2.2 Study eligibility criteria and selection

Articles were included if they were clinical study or trial, including clinical trial phase I, II, III or IV, controlled clinical trial, comparative study, observational study, were published up to five years of the mentioned period of searching (from 2013 to 2018), approached patients with treatment-resistant depression, and described the therapeutic outcome and side-effects of Ketamine. Articles were excluded if they discussed other depressive disturbances besides treatment-resistance depression, used animal models or were review papers.

For eligibility assessment, one author (D.F.) reviewed titles and abstracts of database records and retrieved full texts. The full-text records were reviewed for eligibility by two authors independently (D.F. and M.S.). Disagreements were settled using a consensus process. The manuscripts that were found to be eligible were then independently reviewed and information was retrieved by two authors (D.F. and M.F.). A standard electronic form was used to extract data.

### 3 Results

#### 3.1 Study selection

The search query on Pubmed revealed a total of 580 articles, which were screened for inclusion in the study, and a final number of 21 articles were included (Fig.1). Of the 580 references screened, 56 were selected for full-text reading based on the inclusion and exclusion criteria. For various reasons, 35 of them were excluded. As a result, the systematic review comprised 21 studies. In Figure 1, a PRISMA Flowchart presents the procedures adopted in study selection.

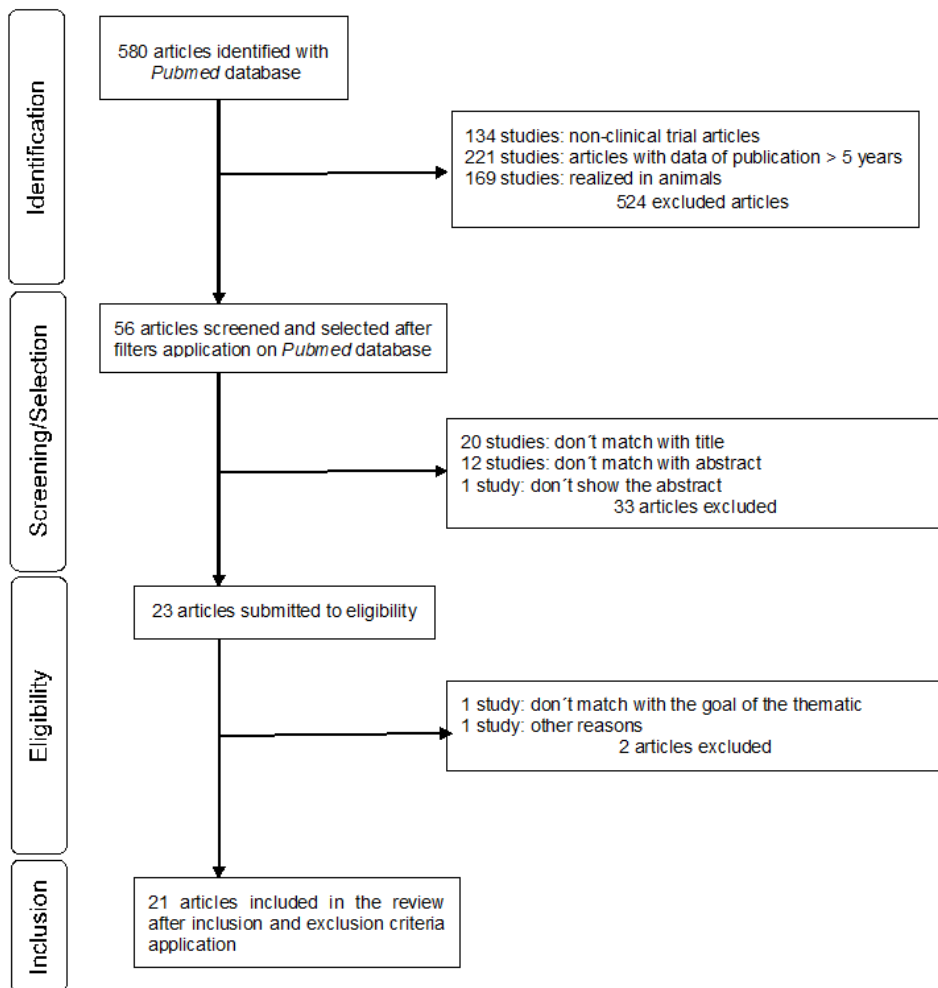

Figure 1. PRISMA diagram of study selection

### 3.2 Rating scores for Depression

The studies included in this systematic review presented different scores to evaluate the Depression severity. Beck Depression Inventory, Brief Psychiatric Rating Scale, Montgomery-Asberg Depression Rating Scale, Clinician Administered Dissociative States Scale, Hamilton Depression Rating Scale and Inventory of Depressive Symptomatology, and Bond-Laden Visual Analogue instruments were among the most used ones [24]–[27][28]. Furthermore, the Systematic Assessment of Treatment Emergent Events (SAFTEE) was reported in the studies to determine the influence of using different administration routes of Ketamine on the incidence of adverse reactions [29].

### 3.3 Primary outcomes: antidepressant properties of ketamine

Modulation of the neuro-circuits may suppress symptomatology caused by depression and provide an improvement in health. Table 1 represents the overall overview characteristics of the antidepressant properties of ketamine. Many of the studies examined the effect of ketamine, observed a decrease of anhedonia, suicidal thoughts, anxiety, and other symptoms with an infusion dose of 0,5 mg/kg in 40 minutes [30], [31]. In addition, the efficacy of ketamine is long-lasting, and some clinical trials have demonstrated a consistent action of ketamine, regardless of whether there has been previous treatments with other psychiatric drugs [32], [33].

Three studies, two of them randomized controlled trials, showed changes in different brain areas, such as in the pregenual anterior dorsal cortex, orbitofrontal cortex, superior temporalis gyrus, prefrontal cortex and habenula with the administration of ketamine [25], [34], [35]. Within these previously mentioned aspects, some remarkable studies reported that ketamine has the ability to increase BDNF levels, causing modulation of neuroplasticity, and conversely a reduction of depression symptoms [36], [37].

To assess the precise beneficial effect of ketamine use, the route of administration was investigated. And it has been found in several studies that the intravenous route promotes, within a few minutes, the attenuation of depressive symptoms, although side effects are more common [29].

In one study, in which the intranasal route was tested, five inhalations of 10 mg ketamine were performed within 20 minutes and the results showed an improvement in depressive symptoms. Thus, the intranasal route is being considered as a possible alternative to the intravenous route, in order to avoid the most likely adverse side effects and with the same therapeutic properties [26].

In order to understand the outcome in the association of ketamine with other drugs, a study used Lanicemine in a double-blind, placebo-controlled, randomized trial and the outcome was an effective antidepressant response [28]. In another study, the administration of ketamine to electroconvulsive therapy and to other drugs such as Clonazepam, Aripiprazole, Diazepam, among others, was considered [26]. Some studies have tested the use of electroconvulsive therapy to enhance ketamine activity in patients with treatment-resistant

---

Depression, and one open-label study reported that one-third of patients gained significant, positive benefit from this procedure [38].

### 3.4 Secondary outcomes: ketamine adverse reactions

In the set of articles included in this systematic review, it was observed that dissociative/psychomimetic symptomatology (13 articles), changes in blood pressure values (10 articles) and headache, nausea, and vomiting (10 articles) were the most frequent adverse reactions. Others may include xerostomia (4 articles), among other less frequent adverse reactions (Table 2).

## 4 Discussion

### 4.1 Antidepressant properties of Ketamine

This paper reviewed the scientific evidence for the use of ketamine in treatment-resistant depression patients.

Ketamine proved to decrease depressive symptoms more efficiently and more rapidly than traditional antidepressants. All studies have really demonstrated the fast and powerful function of intravenous ketamine, which provides an opportunity to use this drug in cases of emergency in clinical practice, for example, suicidal thoughts [39]. Second, several of the studies were randomized controlled trials, which represents an advantage to reduce possible bias [40]. Thirdly, the observed literature applied different measurement scales to assess different parameters of the patient's Depression, which brings more precision to the evaluation and final diagnosis and, consequently, to put into practice the best possible treatment. Finally, while these studies began to offer a new chance to treat severe cases of depression, they also highlighted the fact that more research is needed to assess the effectiveness of ketamine in individuals with treatment-resistant depression. The majority ( $n=13$ ) of the studies mentioned the fast-acting and long-lasting anti-depressant properties of ketamine to minimize symptoms of Depression. Ballard et al., 2017 observed that Ketamine decreased the probability of suicidal ideation in approximately 41% after 230 minutes, due to its anti-anhedonia effect, regardless of whether other symptoms were associated [30]. In another study (Ballard et al., 2014), ketamine minimized the suicide risk however whether depressive and anxiety symptoms were present [8]. Still focusing on the powerful effect of Ketamine, Price, et al., 2014 report that individuals who have an increased baseline risk of suicide and diagnosed treatment-resistant depression are more likely to benefit from ketamine.

The modulation of the glutamatergic system has been taken as an essential target in the treatment of depressive symptoms. To reinforce this, Haile et al., 2014 also found that BDNF levels reached peak plasma levels four hours after intravenous (IV) administration of ketamine at 0.5 mg/kg for 40 minutes, and subsequently Price et al., 2014 made a connection between quinolinic acid receptor inflammation and suicidal thoughts in depression [21].

Table 1. Papers on antidepressant properties of Ketamine

Author, Year	Scales	Trial type	Sample Characteristics	Drug (s)	Dosage	Preview therapeutic	Outcomes
<b>Ballard et al. (2017)</b>	SHAPS BDI SSI HAM-D	Retrospective (obtained from a controlled open-label and two placebo-controlled trials)	N= 100; Age: 18-65 State of health: patients with antidepressant resistant depression and <i>Major</i> Depression or only Bipolar Depression Ethnicity: not shown Study time: 25 hours	Ketamine (IV)	0.5 mg/kg in 40 min.	Riluzole	Decrease of anhedonia and improvement of suicidal thoughts
<b>Li et al. (2016)</b>	_____	Double-blind, placebo-controlled, randomized	N= 26; Age: 19-50 State of health: healthy patients Ethnicity: not shown Study time : 25 hours	Ketamine (IV)	Racemic mix of Ketamine 0.5 mg/kg in 40 min.	_____	Changes in cerebral metabolism that induced a better response to symptoms
<b>Burger et al. (2016)</b>	BHS BSS BDI	Double-blind, placebo-controlled, randomized	N= 10; Age: 18-65 State of health: not shown Ethnicity: Hispanic, Afro-American, Asian, among others Study time : ≥ 11 months	Ketamine (IV)	0.2 mg/kg in 2 min.	_____	Improvement of suicidal thoughts and the majority of symptoms
<b>Singh et al. (2016)</b>	BPRS CADSS CGI MADRS	Double-blind, placebo-controlled, randomized	N= 67; Age: 18-64 State of health: patients with antidepressant resistant depression and <i>Major</i> Depression Ethnicity: not shown Study time : 40 days	Ketamine (IV)	0.5 mg/kg in 40 min. 2/3 times a week	Fluoxetine Citalopram Bupropion	Improvement of symptoms till 15 days

Author, Year	Scales	Trial type	Sample Characteristics	Drug (s)	Dosage	Preview therapeutic	Outcomes
<b>Loo et al. (2016)</b>	BRIEF CADSS MADRS SAFTEE YMRS	Pilot and placebo-controlled	N= 15; IV(n=4), IM(n=5) and SC(n=6) ; Age: ≥ 18 State of health: patients with antidepressant resistant depression and <i>Major</i> Depression Ethnicity: not shown Study time: 7 days	Ketamine (IV/IM/SC)  Midazolam (IV)	Ketamine 0.1 to 0.5 mg/kg OR Midazolam a 0.1 to 0,3 mg/kg in 5 min.	Shock therapy	Variable results from different administration routes with different dosages. In general, all of these induced relief of symptomatology
<b>Lenze et al. (2016)</b>	BPRS CGI MADRS	Pilot, placebo-controlled, randomized clinical trial	N= 20; Age: 18-65 State of health: patients with antidepressant resistant depression and <i>Major</i> Depression Ethnicity: Caucasian and Asian Study time: until 8 weeks	Ketamine (IV)  Clonazepam ( <i>per os</i> )	<u>1<sup>st</sup> phase:</u> Ketamine 0.6 mg/kg/h in 96h OR 95h/20min. <u>2<sup>nd</sup> phase:</u> At last 40 min., ketamine 0.5 mg/kg OR Clonidine 0,6 mg	Shock therapy	High levels of ketamine had sustained in the best way the more effective therapeutic response
<b>Li et al. (2016)</b>	BPRS HDRS-17	Placebo-controlled, randomized	N= 48; Age: 21-65 State of health: patients with antidepressant resistant depression Ethnicity: not shown Study time : 2 years	Ketamine (IV)	0.2 and 0.5 mg/kg in 40 min.	Aripiprazole Quetiapine Valproic Acid Lithium SSRI SSNRI Bupropion	Group A and B had an effective response caused by Ketamine in PFC, MSA, AMS, ADCC and PCT. Values of SCV were low in cerebellar amygdala and higher in PFC.

Author, Year	Scales	Trial type	Sample Characteristics	Drug (s)	Dosage	Preview therapeutic	Outcomes
<b>Singh et al. (2015)</b>	BPRS IDS-C <sub>90</sub> MADRS CADSS C-SSRS	Double-blind, placebo-controlled, randomized	N= 30; Age: 18-64 State of health: patients with antidepressant resistant depression Ethnicity: white patients and others Study time: 4 weeks	Esketamine (IV)	0.20 OR 0.40 mg/kg in 40 min.	Mirtazapine Paroxetine Escitalopram Bupropion Sertraline Venlafaxine Duloxetine	After 2 hours, the drug had induced a quick and a huge improvement in symptoms
<b>Hu et al. (2016)</b>	BPRS CADSS MADRS YMRS	Placebo-controlled, randomized	N= 30; Age: 18-60 State of health: patients with antidepressant resistant depression and with suicidal clinical report Ethnicity: not shown Study time: 2 years and 3 months	Ketamine (IV) Escitalopram ( <i>per os</i> )	Escitalopram 10 mg/day + 0.5 mg/kg Ketamine OR Escitalopram 10 mg/day + Placebo (saline solution) in 40 min.	_____	<i>Escitalopram + Placebo</i> group had revealed An improvement of depression symptoms until 2 weeks
<b>Salehi et al. (2015)</b>	HDRS-17	Double-blind randomized clinical trial	N= 160; Age: 20-60 State of health: patients with antidepressant resistant depression and had experimented shock therapy after use of ketamine or thiopental sodium Ethnicity: not shown Study time: not shown	Ketamine (IV) Sodium Thiopental (IV)	Ketamine 0.8 mg/kg OR Sodium Thiopental 1-1.5 mg/kg	_____	Ketamine is more effective than Sodium Thiopental on the recover-phase and in the reduction of the symptoms



Author, Year	Scales	Trial type	Sample Characteristics	Drug (s)	Dosage	Preview therapeutic	Outcomes
<b>Preskorn et al. (2015)</b>	BECH-6 BPRS+ C-SSRS HDRS-17	Double-blind, placebo-controlled, randomized	N= 116; Age: 18-65 State of health: patients with antidepressant resistant depression Ethnicity: Native American, Asian, White, Black and others Study time: 1 year and 3 months	GLYX-13 (IV)	1, 5, 10 or 30 mg/kg until 28 days	Paroxetine	5 or 10 mg/kg (IV) had reduced the symptoms over 7 days
<b>Lally et al. (2015)</b>	CADSS MADRS SHAPS SPM5	Double-blind, placebo-controlled, randomized	N= 52; Age: not shown State of health: patients with antidepressant resistant depression and <i>Major</i> Depression Ethnicity: Caucasian Study time: 4 weeks	Ketamine (IV) Riluzole ( <i>per os</i> )	Ketamine hydrochloride 0.5 mg/kg in 40 min. OR Riluzole 50-200 mg/day in 4 weeks	Fluoxetine	Reduction in dissociative symptoms and patients with a alcohol disturbance in the past had a better experience with the effect of Ketamine than the others who never ever had any problem with this drink
<b>Ballard et al. (2014)</b>	BDI HAM-A HAM-D SSI	Retrospective (obtained from a double blind, placebo-controlled, crossover trial)	N= 133; Age: 18-65 State of health: patients with antidepressant resistant depression and <i>Major</i> Depression or Bipolar Depression type I/II Ethnicity: not shown Study time: ~ 4 days	Ketamine (IV)	0.5 mg/kg in 40 min.	_____	An increase to desire to live and a less expectation to desire to die and suicidal thoughts when the symptoms and the anxiety are controlled

Author, Year	Scales	Trial type	Sample Characteristics	Drug (s)	Dosage	Preview therapeutic	Outcomes
Lai et al. (2014)	BPRS CADSS CGI MADRS SAFTEE YMRS	Double-blind, pilot and placebo-controlled	N= 4; Age: $\geq 18$ years State of health: patients with antidepressant resistant depression and <i>Major</i> Depression Ethnicity: not shown Study time: 7 days	Ketamine (IV)	0.1 -0.4 mg/kg in 2-5 min.	Alprazolam Olanzapine Quetiapine Tranilcipromine ; Shock therapy	Reduction of the symptoms including the use of the lower dosage of the drug
Lapidus et al. (2014)	BPRS CADSS HAM-A MADRS YMRS	Double-blind, placebo-controlled, randomized	N= 20; Age: 21-65 years State of health: patients with antidepressant resistant depression and <i>Major</i> Depression Ethnicity: Caucasian, Asian, Black, Hispanic and others Study time: 1 week	Ketamine (IN)	5 inhalations of 10 mg in 20 min.	Shock therapy	Improvement of depressive symptoms ( $p<0.05$ and $p<0.001$ ). Via intranasal was well tolerated and not caused significant changes in hemodynamic parameters.
Diamond et al. (2014)	BDI HSRD VAS	Open-label	N= 28; Age: not shown State of health: patients with antidepressant resistant depression and with Unipolar or Bipolar Depression Ethnicity: not shown Study time: 26 weeks	Ketamine (IV)	3 or 6 administrations 0.5 mg/kg in 40 min., inside of recover-time after shock therapy	Aripipazole Clonazepam Diazepam Duloxetine Fluoxetine Gabapentin Olanzapine (...) Shock therapy	Only 1/3 of patients had effective results with this therapy. The shock therapy allowed the monitoring of Ketamine's therapeutic

Author, Year	Scales	Trial type	Sample Characteristics	Drug (s)	Dosage	Preview therapeutic	Outcomes
<b>Price et al. (2014)</b>	BHS CADSS IAT MADRS STAI-S VAS	Placebo-controlled, randomized	N= 57; Age: not shown State of health: patients with antidepressant resistant depression Ethnicity: Caucasian not Hispanics Study time: 2 days at hospital	Ketamine (IV)  Midazolam (IV)	Ketamine hydrochloride 0.5 mg/kg OR Midazolam 0.045 mg/kg in 40 min.	_____	Improvement of symptoms and Ketamine was more effective in those who have high level of suicidal thoughts
<b>Sanacora et al. (2013)</b>	BL-VAS BPRS CADSS CGI-I CGI-S HAM-A HAM-D MADRS	Double-blind, placebo-controlled, randomized	N= not shown; Age: 30-45 years State of health: patients with normal state of antidepressant resistant depression and <i>Major</i> Depression or moderate/high level of antidepressant resistant depression and <i>Major</i> Depression (1 <sup>st</sup> phase) Ethnicity: not shown Study time: 8 weeks	Lanicemine (IV)  Ketamine (IV)	<u>1<sup>st</sup> phase:</u> 75 and 150 mg Lanicemine and 0.5 mg/kg Ketamine <u>2<sup>nd</sup> phase type A:</u> 100 mg Lanicemine in 30 min. <u>2<sup>nd</sup> phase type B:</u> treatment in 3 weeks	_____	Both dosages of Lanicemine had demonstrated an effective antidepressant response. Adverse events had reported with the use of both drugs but in less scale with Ketamine
<b>Haile et al. (2013)</b>	MADRS	Double-blind randomized clinical trial	N= 22; Age: 21-80 years State of health: patients with antidepressant resistant depression Ethnicity: not shown Study time : 7 days	Ketamine (IV)  Midazolam (IV)	0.5 mg/kg Ketamine OR 0.045 mg/kg Midazolam in 40 min.	_____	Ketamine had increased the plasma levels of NFDB and the cortical somatosensory response

Author, Year	Scales	Trial type	Sample Characteristics	Drug (s)	Dosage	Preview therapeutic	Outcomes
Carlson et al. (2013)	MADRS	Open-label	N= 20; Age: 18-65 years State of health: patients with no therapy for antidepressant resistant depression and Major Depression Ethnicity: not shown Study time: until 3 days	Ketamine (IV)	Racemic Ketamine Hydrochloride 0.5 mg/kg in 40 min.	Shock therapy	Metabolic changes in specific regions on the brain such as habenulla and gyrus temporalis superior were reported
Jr et al. (2012)	MADRS YMRS	Double-blind randomized clinical trial	N= 30; Age: 18-65 State of health: patients with antidepressant resistant depression and Major Depression Ethnicity: not shown Study time: 2 days	Ketamine (IV)	Ketamine hydrochloride 0.5 mg/kg in 40 min.	_____	Levels of NFDB and LAW had increased although this final occurred over the first non-REM episode

ADCC – Anterior Dorsal Cingulate Cortex ; AMS – Motor Supplemental Area ; ARD- Antidepressant Resistant Depression ; BD – Bipolar Depression ; BDI - Beck Depression Inventory ; BHS- Back Hopelessness Suicidality ; BL-VAS- Bond-Lader Visual Analogue Scale ; BPRS - Brief Psychiatric Rating Scale ; BSS - Back Suicidality Scale ; CADSS - Clinician -Administered Dissociative States Scale ; CGI- Clinical Global Impressions ; CGI-I- Clinical Global Impressions of Improvement ; CGI-S- Clinical Global Impressions of Severity ; C-SSRS - Colombia- Suicide Severity Rating Scale; h – hours ; HAM-A - Hamilton Anxiety Rating Scale ; HAM-D- Hamilton Depression Rating Scale ; HDRS-17- Hamilton Depression Rating Scale (17 items) ; IAT- Implicit Association Test; IDS-C<sub>30</sub> – Inventory of Depressive Symptomatology- Clinician Rated ; IM - route of administration Intramuscular ; IN- route of administration Intranasal ; IV - route of administration Intravenous ; LAW – Low Amplitude Wave ; MADRS - Montgomery-Asberg Depression Rating Scale ; MD - Major Depression ; min. – minutes ; OFC- Orbitofrontal Cortex ; PACC - Pregeminal Anterior Dorsal Cortex ; per os – route of administration Oral ; PCT- Post-Central Turn ; PFC- Pre-frontal Cortex ; REM - Rapid Eye Movement ; SAFTEE - Systematic Assessment for Treatment Emergent Events ; SC – route of administration Subcutaneous ; SHAPS - Snaith-Hamilton Pleasure Scale ; SSI - Scale for Suicide Ideation ; SSNRI- Selective Serotonin and Noradrenaline Reuptake Inhibitor; SSRI- Selective Serotonin Reuptake Inhibitor ; STAI-S - State-Trait Anxiety Inventory Scale ; VCP - Valores de Captação Padronizados YMRS -Young Mania Rating Scale

Table 2. Papers on adverse reactions of Ketamine

Author, Year	Dissociative Symptoms	(psicomimetic) Anxiety	Changes in Blood Pressure or Heartbeats	Thiredness	Changes in Vision	Changes in Sleep	Suicidal thoughts or Suicide	Confusion	Dizziness	Headache, Nausea or/ and Vomiting	Specific Symptoms
Ballard et al. (2017)	(-)	(-)	(-)	(-)	(-)	(-)	(-)	(-)	(-)	(-)	(-)
Li et al. (2016)	(-)	(-)	(-)	(-)	(-)	(-)	(-)	(-)	(-)	(-)	(-)
Burger et al. (2016)	(-)	(-)	(-)	(-)	(-)	(-)	(-)	(-)	(-)	(-)	(-)
Singh et al. (2016)	(+)	(+)	(-)	(-)	(-)	(-)	(+)	(+)	(+)	(+)	Cold sensation, Hypoaesthesia (...)
Loo et al. (2016)	(+)	(-)	(+)	(+)	(+)	(-)	(-)	(+)	(+)	(-)	Xerostomia, Emotional lability
Lenze et al. (2016)	(+)	(+)	(+)	(-)	(+)	(+)	(-)	(+)	(-)	(+)	Sialorrhea, Changes in production of hepatic enzymes (...)
Li et al. (2016)	(+)	(-)	(-)	(-)	(-)	(-)	(-)	(+)	(-)	(+)	Cry
Singh et al. (2015)	(+)	(-)	(+)	(-)	(-)	(-)	(-)	(+)	(-)	(+)	Xerostomia, Oropharyngeal pain, Paresthesia (...)
Hu et al. (2016)	(+)	(-)	(+)	(+)	(+)	(+)	(-)	(-)	(+)	(+)	Xerostomia, Diarrhea, Sialorrhea, Restlessness



Author, Year	Dissociative Symptoms (psicomimetic disturbances)	Anxiety	Changes in Blood Pressure or Heartbeats	Tiredness	Changes in Vision	Changes in Sleep	Suicidal thoughts or Suicide	Confusion	Dizziness	Headache, Nausea or/and Vomiting	Specific symptoms
Carlson et al. (2013)	(-)	(-)	(-)	(-)	(-)	(-)	(-)	(-)	(-)	(-)	(-)
Jr et al. (2012)	(-)	(-)	(-)	(-)	(-)	(-)	(-)	(-)	(-)	(-)	(-)

UTI – Urinary Tract Infection  
 (+) symptom present; (-) symptom not present

The deregulated sleep activity has been related to the resistance of conventional treatments of Depression in detriment of the cerebral metabolism changes observed. For example, Duncan et al., 2013 discovered a correlation expressed between the values obtained from low amplitude waves in non-REM episode and BDNF through electroencephalogram analysis which, in turn, promoted an improvement in the depressive mood [20]. Even according to this and as considered upon, Ketamine (an inhibitor of N-methyl-D-aspartate receptor) is more effective with higher severity symptomatology. Gorgulu & Caliyurt, 2009 indicates that sleep deprivation contributes to the production of a great amount of neurotrophic factors and recruitment of AMPA receptors which doesn't happen with the most of antidepressants due to the fact that adjustment of synaptic neuroplasticity occurs only a few weeks later. Metabolic activity is increased in individuals with this type of Depression, for example, in the right habenula region, middle temporal gyrus and, controversially, reduced at the right cerebellar amygdala. However, the habenular stimulation area is a particular region of interest to understand the rapid and vigorous ketamine effect on the neuronal metabolism cells [9].

Many of the studies included in this review used a 0.5 mg/kg dosage. However, some of them demonstrated that dosages below 0.5 mg/kg may be enough to reach the similar effectiveness of the usual dosage. Katalinic et al., 2013 referred to a subanesthetic dosage of 0.2 mg/kg might be sufficient to revert quickly and efficiently all depressive symptoms [25]. In a double-blind, randomized and placebo-controlled study, Singh et al., 2016 found that Ketamine when administered 0.5 mg/kg twice a week the response rate was around 69% [17].

The administration route is one of the most important features must be checked to ensure the efficacy and safety of the treatment. Furthermore, some alternatives such as Oral (*per os*), Sublingual, Intramuscular (IM), Intravenous (with more evidence in literature), Subcutaneous (SC) and Intranasal (IN) have been reported in the literature. Recently, IN route may be appointed as an option to treat resistant-depression because of the prominent reduction of adverse-effects. The only disadvantage is related to the fact of IN route has a lower half-time than the IV route [26]. Currently, Esketamine (an isomer obtained from Ketamine) nasal spray - Spravato® - displayed impressive improvements in depressive symptomatology when compared to a common oral administration [42]. In addition, Loo et al., 2016 showed some comparisons between administration routes: IM has similar efficacy when compared with the SC and IV route [13]. However, both IM and IV routes are more rapid to generate a physiological response. SC route also brings several advantages due to its efficacy/side-effects ratio.

Combining other medications with ketamine can aid recovery. Lenze et al., 2016 found that clonidine, when co-administered with Ketamine, decreases the severity of symptoms without minimizing the antidepressant effect. In another study. Hu et al., 2015 verified that when Escitalopram and Ketamine were both administered, an increased ketamine plasma concentration was observed. Accordingly, they considered that Escitalopram acts as a catalyst/enhancer of ketamine activity.

Electroconvulsive therapy is recognized as a complementary treatment for resistant-treatment depression. In the study of Salehi, et al, 2015 they concluded that Ketamine, when



---

given before Electroconvulsive procedures, was beneficial [16]. Although seizures and blood pressure changes are present, the proven benefits outweigh its risks, and this drug may complement the treatment with electroconvulsive therapy. Similarly, D-cycloserine - a partial agonist of the Glycine with the binding site in the NR2B receptors of NMDA - is mentioned because of their antidepressant properties and practically no psychomimetic/dissociative adverse effects [11]. Other drugs have been described, such as Memantine and Lanicemine (weak NMDA receptor blockers) [27].

## 4.2 Adverse reactions induced by Ketamine

Preskorn et al., 2015 mentioned the challenge in depression is to find new effective therapies with a low risk of adverse reactions [11]. For example, GLYX-13 (a partial NMDA receptor antagonist) may be equally effective with a much lower quantity of side-effects than Ketamine. Between the more frequent side-effects found in Table 2 (dissociative symptoms and hearth parameters changes), most of them are attenuated with successive administrations over 2 hours and after Ketamine administration [17]. So, Loo et al., 2016 demonstrated the risk of some administration routes to side-effects appears discussing IV route as the main responsible for the beginning of those symptoms [13].

The association of other drugs might be beneficial as previously mentioned. As an example, Lenze et al., 2016 had proved the use of ketamine with Clonidine for a consecutive period of 96 hours and this resulted in a minimization of side-effects even Ketamine plasma concentrations were elevated [27].

In relation to Electroconvulsive therapy, Salehi et al., 2015 recommended administrating Ketamine before the electroconvulsive procedure because seizure duration is prolonged when both are used at the same time [16].

The side-effects are also explained by the possible mechanisms of Ketamine: extra-synaptic inhibition of NMDA receptors, blockade of the activation of NMDA receptor, production of metabolites (hydroxynorketamine) and inhibition of NMDA receptors in lateral habenulla area [43]. To better understand how Ketamine performs, Sanacora et al., 2013 encourage to the research of biomarkers to identify changes during treatment with Ketamine in individuals with resistance to the traditional antidepressants, specifically in brains areas more affected by the symptomatology of the disease [12].

## 4.3 Study limitations and future perspectives

For this systematic review, we identified several limitations. Most studies were conducted in small samples, the majority using intravenous administration and with a fixed dosage for Ketamine, additionally, heterogenous rating scores were used to classify depressive symptoms. Taken in account these limitations, further studies should address different routes of ketamine administration, different dosages, and frequencies of administration to analyze the most suitable treatment. Regarding sample size, studies including large samples should be developed. Finally, it would be beneficial to search for new targets on the glutamatergic

pathway, to explore the allosteric modifications of the BDNF TRKB receptor, and, finally, the sphingolipid system which may give hope for the development of new, rapid-acting antidepressants.

## 5 Conclusions

In this systematic review, ketamine has been shown to be effective when given to individuals with treatment resistant depression, particularly those who present a more aggressive phenotype (suicidal ideation). This drug represents a powerful tool to suppress depression due to the resynchronization of neural circuits upon its use. However, ketamine was also associated with several induced side-effects, including changes in blood pressure, dissociative symptoms, headache, nausea and vomits, which may limit its use. Different routes of administration and ketamine metabolites may be explored to overcome some of these induced side-effects. Furthermore, new research should focus on innovative therapeutic approaches, targeting mTORC1 signaling pathway, and the BDNF TRKB receptor allosteric manipulation.

## Disclosure statement

The authors identified no conflicts of interest. The authors alone are responsible for the content and writing of the paper.

## References

- [1] World Health Organization, “Depression and other common mental disorders: global health estimates,” *World Health Organ.*, pp. 1–24, 2017, doi: CC BY-NC-SA 3.0 IGO.
- [2] American Psychiatric Association and American Psychiatric Association, Eds., *Diagnostic and statistical manual of mental disorders: DSM-5*, 5th ed. Washington, D.C: American Psychiatric Association, 2013.
- [3] Direção Geral de Saúde, “Depressão e outras Perturbações Mentais Comuns,” pp. 1–104, 2017.
- [4] U. E. Lang and S. Borgwardt, “Molecular Mechanisms of Depression: Perspectives on New Treatment Strategies,” *Cell. Physiol. Biochem.*, vol. 31, no. 6, pp. 761–777, 2013, doi: 10.1159/000350094.
- [5] A. S. F. Kwong *et al.*, “Genetic and Environmental Risk Factors Associated With Trajectories of Depression Symptoms From Adolescence to Young Adulthood,” *JAMA Netw. Open*, vol. 2, no. 6, p. e196587, Jun. 2019, doi: 10.1001/jamanetworkopen.2019.6587.

- 
- [6] S. M. Stahl, *Stahl's essential psychopharmacology: neuroscientific basis and practical application*, 4th ed. Cambridge ; New York: Cambridge University Press, 2013.
- [7] R. M. Hirschfeld, "History and evolution of the monoamine hypothesis of depression," *J. Clin. Psychiatry*, vol. 61 Suppl 6, pp. 4-6, 2000.
- [8] G. Hasler, "Pathophysiology of depression: do we have any solid evidence of interest to clinicians?," *World Psychiatry*, vol. 9, no. 3, pp. 155-161, Oct. 2010, doi: 10.1002/j.2051-5545.2010.tb00298.x.
- [9] J. Mikulska, G. Juszczak, M. Gawrońska-Grzywacz, and M. Herbet, "HPA Axis in the Pathomechanism of Depression and Schizophrenia: New Therapeutic Strategies Based on Its Participation," *Brain Sci.*, vol. 11, no. 10, p. 1298, Sep. 2021, doi: 10.3390/brainsci11101298.
- [10] E. Castrén and T. Rantamäki, "The role of BDNF and its receptors in depression and antidepressant drug action: Reactivation of developmental plasticity," *Dev. Neurobiol.*, vol. 70, no. 5, pp. 289-297, Apr. 2010, doi: 10.1002/dneu.20758.
- [11] R. S. Duman and N. Li, "A neurotrophic hypothesis of depression: role of synaptogenesis in the actions of NMDA receptor antagonists," *Philos. Trans. R. Soc. Lond. B. Biol. Sci.*, vol. 367, no. 1601, pp. 2475-2484, Sep. 2012, doi: 10.1098/rstb.2011.0357.
- [12] J. C. Felger and F. E. Lotrich, "Inflammatory cytokines in depression: Neurobiological mechanisms and therapeutic implications," *Neuroscience*, vol. 246, pp. 199-229, Aug. 2013, doi: 10.1016/j.neuroscience.2013.04.060.
- [13] G. E. Hodes, V. Kana, C. Menard, M. Merad, and S. J. Russo, "Neuroimmune mechanisms of depression," *Nat. Neurosci.*, vol. 18, no. 10, pp. 1386-1393, Oct. 2015, doi: 10.1038/nn.4113.
- [14] G. Sanacora, G. Treccani, and M. Popoli, "Towards a glutamate hypothesis of depression," *Neuropharmacology*, vol. 62, no. 1, pp. 63-77, Jan. 2012, doi: 10.1016/j.neuropharm.2011.07.036.
- [15] B. Kadriu, L. Musazzi, I. D. Henter, M. Graves, M. Popoli, and C. A. Zarate, "Glutamatergic Neurotransmission: Pathway to Developing Novel Rapid-Acting Antidepressant Treatments," *Int. J. Neuropsychopharmacol.*, vol. 22, no. 2, pp. 119-135, Feb. 2019, doi: 10.1093/ijnp/pyy094.
- [16] S. J. Mathew *et al.*, "Ketamine for Treatment-Resistant Unipolar Depression: Current Evidence," *CNS Drugs*, vol. 26, no. 3, pp. 189-204, Mar. 2012, doi: 10.2165/11599770-000000000-00000.

- 
- [17] K. E. DeWilde, C. F. Levitch, J. W. Murrough, S. J. Mathew, and D. V. Iosifescu, "The promise of ketamine for treatment-resistant depression: current evidence and future directions: Ketamine for treatment-resistant depression," *Ann. N. Y. Acad. Sci.*, vol. 1345, no. 1, pp. 47–58, May 2015, doi: 10.1111/nyas.12646.
- [18] C. G. Abdallah, G. Sanacora, R. S. Duman, and J. H. Krystal, "Ketamine and Rapid-Acting Antidepressants: A Window into a New Neurobiology for Mood Disorder Therapeutics," *Annu. Rev. Med.*, vol. 66, no. 1, pp. 509–523, 2015, doi: 10.1146/annurev-med-053013-062946.
- [19] G. Mion and T. Villeveille, "Ketamine pharmacology: an update (pharmacodynamics and molecular aspects, recent findings)," *CNS Neurosci. Ther.*, vol. 19, no. 6, pp. 370–380, Jun. 2013, doi: 10.1111/cns.12099.
- [20] K. Hashimoto, "Molecular mechanisms of the rapid-acting and long-lasting antidepressant actions of (R)-ketamine," *Biochem. Pharmacol.*, vol. 177, p. 113935, Jul. 2020, doi: 10.1016/j.bcp.2020.113935.
- [21] V. Lewis *et al.*, "Translational control by ketamine and its implications for comorbid cognitive deficits in depressive disorders," *J. Neurochem.*, p. jnc.15652, Jun. 2022, doi: 10.1111/jnc.15652.
- [22] A. Aguilar-Valles *et al.*, "Antidepressant actions of ketamine engage cell-specific translation via eIF4E," *Nature*, vol. 590, no. 7845, pp. 315–319, Feb. 2021, doi: 10.1038/s41586-020-03047-0.
- [23] Stephen M. Stahl, *Prescriber's Guide*, 5<sup>th</sup>. EUA: Cambridge University Press, 2014.
- [24] E. D. Ballard *et al.*, "Improvement in suicidal ideation after ketamine infusion: Relationship to reductions in depression and anxiety," *J. Psychiatr. Res.*, vol. 58, pp. 161–166, Nov. 2014, doi: 10.1016/j.jpsychires.2014.07.027.
- [25] P. J. Carlson *et al.*, "Neural Correlates of Rapid Antidepressant Response to Ketamine in Treatment-Resistant Unipolar Depression: A Preliminary Positron Emission Tomography Study," *Biol. Psychiatry*, vol. 73, no. 12, pp. 1213–1221, Jun. 2013, doi: 10.1016/j.biopsych.2013.02.008.
- [26] K. A. B. Lapidus *et al.*, "A Randomized Controlled Trial of Intranasal Ketamine in Major Depressive Disorder," *Biol. Psychiatry*, vol. 76, no. 12, pp. 970–976, Dec. 2014, doi: 10.1016/j.biopsych.2014.03.026.
- [27] S. Preskorn, M. Macaluso, D. V. Mehra, G. Zammit, J. R. Moskal, and R. M. Burch, "Randomized Proof of Concept Trial of GLYX-13, an N-Methyl-D-Aspartate Receptor Glycine Site Partial Agonist, in Major Depressive Disorder Nonresponsive to a Previous Antidepressant Agent," *J. Psychiatr. Pract.*, vol. 21, no. 2, pp. 140–149, Mar. 2015, doi: 10.1097/01.pra.0000462606.17725.93.

- 
- [28] G. Sanacora *et al.*, “Lanicemine: a low-trapping NMDA channel blocker produces sustained antidepressant efficacy with minimal psychotomimetic adverse effects,” *Mol. Psychiatry*, vol. 19, no. 9, pp. 978–985, Sep. 2014, doi: 10.1038/mp.2013.130.
- [29] C. K. Loo *et al.*, “Placebo-controlled pilot trial testing dose titration and intravenous, intramuscular and subcutaneous routes for ketamine in depression,” *Acta Psychiatr. Scand.*, vol. 134, no. 1, pp. 48–56, Jul. 2016, doi: 10.1111/acps.12572.
- [30] E. D. Ballard *et al.*, “Anhedonia as a clinical correlate of suicidal thoughts in clinical ketamine trials,” *J. Affect. Disord.*, vol. 218, pp. 195–200, Aug. 2017, doi: 10.1016/j.jad.2017.04.057.
- [31] N. Lally, A. C. Nugent, D. A. Luckenbaugh, M. J. Niciu, J. P. Roiser, and C. A. Zarate, “Neural correlates of change in major depressive disorder anhedonia following open-label ketamine,” *J. Psychopharmacol. (Oxf.)*, vol. 29, no. 5, pp. 596–607, May 2015, doi: 10.1177/0269881114568041.
- [32] B. Salehi, A. Mohammadbeigi, A. Kamali, M. Taheri-Nejad, and I. Moshiri, “Impact comparison of ketamine and sodium thiopental on anesthesia during electroconvulsive therapy in major depression patients with drug-resistant; a double-blind randomized clinical trial,” *Ann. Card. Anaesth.*, vol. 18, no. 4, p. 486, 2015, doi: 10.4103/0971-9784.166444.
- [33] J. B. Singh *et al.*, “A Double-Blind, Randomized, Placebo-Controlled, Dose-Frequency Study of Intravenous Ketamine in Patients With Treatment-Resistant Depression,” *Am. J. Psychiatry*, vol. 173, no. 8, pp. 816–826, Aug. 2016, doi: 10.1176/appi.ajp.2016.16010037.
- [34] C.-T. Li *et al.*, “The effects of low-dose ketamine on the prefrontal cortex and amygdala in treatment-resistant depression: A randomized controlled study: Ketamine Modulates the PFC,” *Hum. Brain Mapp.*, vol. 37, no. 3, pp. 1080–1090, Mar. 2016, doi: 10.1002/hbm.23085.
- [35] M. Li *et al.*, “Temporal Dynamics of Antidepressant Ketamine Effects on Glutamine Cycling Follow Regional Fingerprints of AMPA and NMDA Receptor Densities,” *Neuropsychopharmacology*, vol. 42, no. 6, pp. 1201–1209, Jan. 2016, doi: 10.1038/npp.2016.184.
- [36] W. C. Duncan *et al.*, “Concomitant BDNF and sleep slow wave changes indicate ketamine-induced plasticity in major depressive disorder,” *Int. J. Neuropsychopharmacol.*, vol. 16, no. 02, pp. 301–311, Mar. 2013, doi: 10.1017/S1461145712000545.
- [37] C. N. Haile *et al.*, “Plasma brain derived neurotrophic factor (BDNF) and response to ketamine in treatment-resistant depression,” *Int. J. Neuropsychopharmacol.*, vol. 17, no. 02, pp. 331–336, Feb. 2014, doi: 10.1017/S1461145713001119.

- [38] P. R. Diamond *et al.*, “Ketamine infusions for treatment resistant depression: a series of 28 patients treated weekly or twice weekly in an ECT clinic,” *J. Psychopharmacol. (Oxf.)*, vol. 28, no. 6, pp. 536–544, Jun. 2014, doi: 10.1177/0269881114527361.
- [39] J. Burger *et al.*, “A Double-Blinded, Randomized, Placebo-Controlled Sub-Dissociative Dose Ketamine Pilot Study in the Treatment of Acute Depression and Suicidality in a Military Emergency Department Setting,” *Mil. Med.*, vol. 181, no. 10, pp. 1195–1199, Oct. 2016, doi: 10.7205/MILMED-D-15-00431.
- [40] D. C. Jupiter, “Propensity Score Matching: Retrospective Randomization?,” *J. Foot Ankle Surg.*, vol. 56, no. 2, pp. 417–420, Mar. 2017, doi: 10.1053/j.jfas.2017.01.013.
- [41] N. Katalinic, R. Lai, A. Somogyi, P. B. Mitchell, P. Glue, and C. K. Loo, “Ketamine as a new treatment for depression: A review of its efficacy and adverse effects,” *Aust. N. Z. J. Psychiatry*, vol. 47, no. 8, pp. 710–727, Aug. 2013, doi: 10.1177/0004867413486842.
- [42] N. J. Titusville, “New Phase 3 Data Show Esketamine Nasal Spray Demonstrated Rapid Improvements in Depressive Symptoms in Patients with Treatment-Resistant Depression,” *U. S.*, 2018, [Online]. Available: <https://www.janssen.com/new-phase-3-data-show-esketamine-nasal-spray-demonstrated-rapid-improvements-depressive-symptoms>
- [43] P. Zanos and T. D. Gould, “Mechanisms of ketamine action as an antidepressant,” *Mol. Psychiatry*, vol. 23, no. 4, pp. 801–811, Apr. 2018, doi: 10.1038/mp.2017.255.

# Potential Drug Interactions between Oral Antineoplastic Agents and Opioid Analgesics

Cláudia Antunes<sup>1</sup>, Daniel Carvalho<sup>1</sup>, Ângelo Jesus<sup>2</sup>

<sup>1</sup> Escola Superior de Saúde (ESS) – Instituto Politécnico do Porto (IPP), Porto, Portugal  
{10170212, 10170218}@ess.ipp.pt

<sup>2</sup> Centro de Investigação em Saúde e Ambiente (CISA) – Escola Superior de Saúde (ESS) –  
Instituto Politécnico do Porto (IPP), Portugal  
acj@ess.ipp.pt

**Abstract.** *Oral antineoplastic drugs use has been gaining more importance due to its multiple benefits and the introduction of new molecules with new mechanisms of action. Opioids are often conjugated with antineoplastic therapy, however, this association brings possible drug interactions. Cytochrome P450 is responsible for the metabolization of a great part of drugs on the market. Identifying, explaining, and assessing the severity of possible drug interactions between oral antineoplastic agents and opioid analgesics were the aims of this investigation. A cross-sectional observational study was developed. Drugs selected in FHNM, were combined one by one in the Micromedex database. Twenty-three interactions were found with different types of grades of evidence and severity, and six were explained. Procarbazine was the oral antineoplastic with the highest number of possible interactions, while the opioid was buprenorphine. It's important to monitor drug interactions in cancer patients considering the serious consequences that may arise from these.*

**Keywords.** Antineoplastic agents, opioid analgesics, drug interactions, cancer therapy, pain management

## 1 Introduction

### 1.1 Oral Antineoplastic Agents

As a result of the increasing number of people diagnosed with cancer, as well as, the development of new agents with different mechanisms of action, the use of oral antineoplastic agents has been increasing [1], [2]. A primary goal of treatment with antineoplastic agents is to treat cancer, increase life expectancy and bring quality of life [1].

By using oral chemotherapy, multiple benefits have been demonstrated when compared with traditional methods, in particular for quality of life [2]. This is thanks to the administration at home by the patient, thus avoiding constant hospital visits for treatments, as well as, decreasing the dependence on caregivers and also maintaining a relatively constant level of medication throughout the treatment period [2]. Furthermore, the use of these agents eliminates the risk of developing infections derived from IV access of intravenous chemotherapy, because this isn't an invasive method [3].

There are four phases in the cell cycle: the pre-synthetic phase or G1, the phase in which DNA synthesis takes place or phase S, the post-synthesis phase or G2, and mitosis phase or phase M [4]. Traditional oral antineoplastic agents damage cancer cells and interfere with their cellular division [5]. Most of these agents can be distinguished by the cell cycle phase in which they interfere. Etoposide acts in the G2 phase, and inhibits topoisomerase II, preventing cells from entering the M phase of the cell cycle where mitosis normally occurs [5]. Antimetabolites, such as methotrexate, interfere in the S phase of the cell cycle, more precisely in the synthesis of nucleic acids, replacing them with purines or pyrimidines or by inhibiting enzymes important in the synthesis of nucleic acids [5]. In the case of alkylating agents such as procarbazine, these are not cell cycle specific, because they act on DNA, replacing an alkyl group with a hydrogen atom, which results in cell death [5].

Nevertheless, the use of these drugs raises an issue: potential drug-drug interactions concerning drug pharmacokinetics. This may have serious consequences which can lead to serious adverse events or a decrease in effect [2].

### 1.2 Opioid Analgesics

Cancer patients are commonly polymedicated, with treatment for comorbidities or with adjuvant therapy to give better support to antineoplastic treatment. Because most of the time these patients look for different clinicians and don't inform them about the drugs that they are using, being polymedicated, as well as age, is a risk factor for potential drug-drug interactions [3].

Pain is a common symptom associated with cancer and its treatments. In a study of more than 5.000 adults, 56% of cancer patients suffer from moderate to severe pain [6]. Its prevalence is greater the more advanced the state of cancer [6]. That is why it is important to look for solutions to limit pain linked to cancer.



Opioids are frequently used to manage pain associated with cancer, as they are indicated for the treatment of moderate to severe pain [6]. Some adverse effects like sedation, nausea/vomiting, and constipation are frequently felt due to the use of opioid analgesics [7]. Moreover, respiratory depression can also occur [7]. Opioids connect to opioid receptors. There are mu ( $\mu$ ), kappa ( $\kappa$ ), and delta ( $\delta$ ) opioid receptors [8]. Mu receptors are those that, when activated by stimulation of a ligand, cause supraspinal analgesia, respiratory depression, euphoria, and sedation, being located in the brainstem or medial thalamus. These are responsible for opioid dependence [8]. Kappa receptors are located in the spinal cord, and brainstem, and when stimulated are at the origin of the actions such as spinal analgesia, sedation, dysphoria, and also dependence [8]. Finally, delta receptors are distributed throughout the brain and whose stimulation causes psychomimetic and dysphoric symptoms [8]. This connection triggers neuronal depolarization [9]. Opioids can be grouped according to their action mechanism, in: agonists (act by connecting to the opioid receptors and this group includes morphine, codeine, and fentanyl), partial agonists (where buprenorphine is included), agonists-antagonists (those who have partial antagonist activity in mu receptors) and antagonists (naltrexone acts like a competitive antagonist in mu receptors) [8].

A process that drugs go through to be eliminated from the body is called metabolism [10]. When metabolism is altered by another drug, this can lead to an increasing concentration of the drug that wasn't properly metabolized, which leads to toxic effects or a reduction in its concentration to complete the objective of its administration [10].

Opioid metabolism is divided into two phases: phase I is responsible for oxidation or hydrolysis by CYP3A4 or CYP2D6, while in phase II there is an increase in hydro-solubility for renal excretion [9], [10]. Drugs such oxycodone, fentanyl, hydrocodone, and methadone are metabolized by CYP3A4, while codeine and tramadol suffer metabolization by CYP2D6. Morphine, hydromorphone, and oxymorphone have minimal or no phase I metabolism [9], [10].

### 1.3 Drug Interactions

Drug interactions are defined as drug combinations that can lead to therapeutic failure and potential adverse events that wouldn't occur if the drugs were administered individually [1].

The potential drug-drug interactions can be distinguished between, pharmacokinetics, pharmacodynamics, and pharmaceutical [11]. Pharmaceutical interactions occur when two incompatible chemical products are associated [11]. Pharmacokinetics interactions are associated with absorption, distribution, metabolism, and elimination of the drug or association [7], [11]. These are frequently related to drug metabolization by cytochrome P450 enzymes, through inhibition or induction of CYP isoenzymes and consequently, blood concentration and anticancer agent toxicity can be altered [11]. The pharmacokinetic interactions can also result in P-glycoprotein inhibition, which can affect antineoplastic bioavailability [11]. When the interactions are the result of the mechanism of action of the drugs involved they are classified as pharmacodynamics [11]. This can lead to synergisms, antagonisms, or additions resulting in beneficial actions or the opposite [11].

Most antineoplastic agents are metabolized by CYP450, acting as inhibitors or inducers of one or more isoenzymes [3], [12]. Cytochrome P450 is responsible for most of the drug's metabolism. Several drug interactions result from alterations of CYP450 metabolism [13].

Drugs can act like CYP450 inhibitors or inducers. Inhibitors are responsible for blocking the metabolic activity of one or more enzymes belonging to the CYP450 enzyme complex, and the effects of this inhibitory action usually occur immediately [13]. Inducers are responsible for increasing the synthesis activity of enzymes belonging to CYP450, however, unlike inhibitors, the increase in enzyme activity does not occur immediately [13]. A drug can be metabolized by an enzyme and in the same way, inhibit the same enzyme [13].

The CYP3A4 isoenzyme is the most related to pharmacokinetic interactions [12]. The main isoenzyme responsible for the metabolism of oral anticancer drugs is CYP3A4 and because these drugs can act like inhibitors or inducers, the concomitant use of oral antineoplastic agents and opioid analgesics can alter opioid metabolism, resulting in higher or reduced concentrations, respectively, of opioids [9], [10]. The P-glycoprotein has a high expression in tissues responsible for absorption, distribution, and elimination, thus limiting the transport and absorption of drugs that may be involved in pharmacokinetic interactions [12]. In tumoral cells P-glycoprotein reduces the intracellular concentration of the drug, limiting the action of chemotherapeutics at the site of infection [12].

Pharmacokinetic interactions are mostly related to CYP450 or P-glycoprotein which influences the efficacy of the drug, regulating its distribution and bioavailability [14].

## 1.4 Micromedex Database

Micromedex is a database developed by IBM. In this database, it is possible to find information such as drug interaction with other drugs, food, or alcohol, for example.

### 1.4.1 Severity

Drug interactions could be grouped according to their severity, that is, they are divided according to the damage that they cause to the patient. So, drug interactions could be classified in the following grades: contraindicated, major, moderate, minor, and unknown.

According to the literature and Micromedex database, a contraindicated interaction means that two or more drugs cannot be administered concurrently [15]. Major interactions are those whose adverse effects can cause permanent damage to the patient or put the patient's life at risk, requiring intervention by health professionals [11], [15]. Moderate type interactions are less severe than major types, however, can change/modify the patient's clinical condition and medical treatment is necessary to reduce exacerbations and reframe the therapeutic regimen [11], [15]. Minor interactions show mild, that is, uncomplicated clinical consequences and therefore do not require medical intervention [11], [15]. When the severity of interaction is classified as unknown, this means there is no information and research on it [15].

### **1.4.2 Grade of Evidence**

A drug interaction's degree of evidence is related to the quantity and quality of underlying documentation for the data provided, the interaction explained, and its severity. This parameter is classified according to the following characteristics: excellent, good, fair, and unknown.

In accordance with Micromedex, the grade of evidence is classified as excellent when the documentation used includes studies that clearly describe the interaction, and these studies were controlled [15]. When the degree of evidence is presented as good, the documentation doesn't represent very controlled studies, however, it strongly suggests that the interaction exists [15]. A fair grade of evidence arises when documentation is poor, however, professionals with available pharmacological evidence suspect the existence of interaction, or else when there is documentation classified as excellent for similar drugs [15]. As in gravity, classification as unknown means there is no information and research on it [15].

There are still no significant studies regarding drug interactions with oral antineoplastic, namely, interactions with opioid analgesics. So, the main objectives of this study were: (a) to identify possible drug-drug interactions between oral antineoplastic agents and opioid analgesics; (b) to assess the severity of drug-drug interactions between oral antineoplastic agents and opioid analgesics, and (c) To describe the mechanisms of interactions.

## **2 Methodology**

In this project, a descriptive cross-sectional observational study was conducted related to drug interactions between oral antineoplastic and opioid analgesics. This investigation was conducted between April 2020 and June 2021.

Potential drug interactions were collected, using the Micromedex database. For this data collection, the drugs used were selected in FHNM ("Formulário Hospitalar Nacional do Medicamento") and combined one by one to find specific drug-drug interactions, their severity, and the grade of evidence. This data collection was carried out on April 23, 2020. The results were organized in an Excel file. Six drug interactions were selected to be properly explained.

## **3 Results**

Following the analysis and collection of the drugs from FHNM, twenty-seven oral antineoplastic agents were selected (anastrozole, azathioprine, bicalutamide, busulfan, chlorambucil, cyclophosphamide, cyproterone, cyclosporine, etoposide, flutamide, hydroxycarbamide, idarubicin, imatinib, letrozole, lomustine, megestrol, melphalan, mercaptopurine, methotrexate, mitotane, mycophenolate mofetil, procarbazine, estramustine, tacrolimus, tamoxifen, thalidomide, and thioguanine) and seven opioid analgesics (buprenorphine, fentanyl, hydromorphone, morphine, oxycodone, tapentadol, and tramadol).

After introducing one hundred and eighty-nine pharmaceutical combinations into Micromedex database, twenty-three interactions were detected (Table 1). Subsequently, analyzing the table, it was observed that the antineoplastic drug with the highest number of potential interactions was procarbazine (seven interactions, being five major and two contraindicated). Regarding opioids, the one with the greatest number of possible interactions (six interactions, in this case, all major) was buprenorphine.

All interactions found were grouped according to severity and grade of evidence (Table 1). Of the twenty-three interactions collected, most had a higher degree of severity (twenty-one interactions), with the remainder being classified as contraindicated.

Regarding the degree of evidence, the twenty-three interactions collected are found to have three different levels of evidence (excellent, good, and fair), with most being fair, only three interactions having an excellent level of evidence, and three others being good.

**Table 1.** Severity and grade of evidence of interactions

<b>Antineoplastic agent</b>	<b>Opioid analgesic</b>	<b>Severity</b>	<b>Grade of evidence</b>
Cyclosporine	Buprenorphine	Major	Fair
	Fentanyl	Major	Excellent
	Morphine	Major	Good
	Oxycodone	Major	Fair
	Tramadol	Major	Fair
Imatinib	Buprenorphine	Major	Excellent
	Fentanyl	Major	Fair
	Oxycodone	Major	Fair
	Tramadol	Major	Fair
Mitotane	Buprenorphine	Major	Fair
	Fentanyl	Major	Excellent
	Oxycodone	Major	Fair
	Tramadol	Major	Fair
Procarbazine	Buprenorphine	Major	Fair
	Fentanyl	Major	Fair
	Hydromorphone	Major	Fair
	Morphine	Major	Good
	Oxycodone	Major	Fair
	Tapentadol	Contraindicated	Fair
	Tramadol	Contraindicated	Fair
Tamoxifen	Buprenorphine	Major	Fair
Tacrolimus	Buprenorphine	Major	Fair
	Fentanyl	Major	Good

## 4 Discussion

Through the results, it is possible to observe the existence of twenty-three drug interactions between oral antineoplastics and opioid analgesics. In this descriptive study, six of these interactions will be addressed. The choice of those to be described was based on criteria related to their classification as to the severity and degree of evidence indicated in Micromedex. In this case, will be addressed those whose severity is major and the degree of evidence excellent or good, since they are the most worrying and documented. To explain the mechanism of interactions, first a little bit of the pharmacokinetics of each drug will be discussed.

### 4.1 Buprenorphine-Imatinib

Buprenorphine, a partial opioid agonist of mu receptors, is used to treat pain, as well as can be used in the treatment of opioid addiction [16]. Since it is a partial agonist it can cause analgesia, sedation, and respiratory depression [4], [16]. This opioid has a large volume of distribution and is extensively bound to plasma proteins [16]. Regarding the metabolism inherent to this drug, it is highly metabolized to norbuprenorphine, an active metabolite, through the CYP3A4 isoenzyme through a reaction called N-dealkylation, which results in an inhibition of the said isoenzyme [16], [17]. Concomitant administration with other drugs known to induce or inhibit this enzyme complex may result in drug interactions that will affect its pharmacokinetics since it will decrease or enhance N-dealkylation which will result in an increase or decrease in the amount of buprenorphine circulating in the body [16].

Imatinib is an inhibitor of tyrosine kinase protein, Bcr-Abl, a fusion oncoprotein, resulting from a translocation present in chronic myeloid leukemia (CML) [18]. Protein tyrosine kinases participate in several cellular processes such as growth, differentiation, metabolism, adhesion, and apoptosis, meaning that the dysregulation of the activity of this protein is associated with several types of cancer, namely chronic myeloid leukemia and gastrointestinal stromal tumor [19]. Since Bcr-Abl was very present in CML, this protein was thought to be the target of inhibition, and imatinib is used for this purpose, which acts on the binding site of adenosine tri-phosphate by competitive inhibition, resulting in selective inhibition of proliferation and apoptosis in Bcr-Abl positive cells not affecting normal cells [19]. The imatinib is quickly absorbed after oral administration [19]. This drug is metabolized mainly in the liver by the isoenzymes CYP3A4 and CYP3A5 [18]. The metabolites of this drug undergo bile excretion [18], [20]. Imatinib metabolism can be decreased and its plasma concentrations increased when administered concomitantly with drugs that inhibit CYP3A4 or CYP3A5 [19]. On the other hand, drugs that induce these enzymes can increase metabolism and decrease exposure to imatinib, as is the case with pro-carbamazepine [19].

According to the Micromedex database, the simultaneous use of CYP3A4 inhibitors with imatinib should be carried out with caution [15]. Knowing that imatinib is a potent inhibitor of CYP3A4 and that this isoenzyme is responsible for the metabolism of buprenorphine to norbuprenorphine, it is possible to understand that there may be an increase in the

concentration of buprenorphine [18]. This increase in the concentration of buprenorphine may result in the inhibition of cardiac repolarization, the prolongation of the QT interval, reduction in heart rate, and respiratory depression which, once installed, can be difficult to reverse [16], [17]. Therefore, it is recommended to monitor the symptoms of the patient who is undergoing antineoplastic therapy together with opioids in adjuvant therapy, as well as to consider reducing the dose of buprenorphine, since in this case, it will result in a lower concentration of opioid in circulation and therefore fewer adverse effects [15].

## 4.2 Fentanyl-Mitotane

Fentanyl is a drug belonging to the group of opioid analgesics,  $\mu$ -receptor agonists, which when acting on opioid receptors gives rise to analgesic and sedative effects, being used in the maintenance of cancer-associated pain [21]–[23]. In terms of metabolism, this drug is metabolized, in the first stage, by the enzyme CYP3A4 present in the liver, responsible for a first-pass process (N-dealkylation) [23]. This type of metabolism can give rise to various drug interactions when fentanyl is administered concomitantly with inducers or inhibitors of the CYP3A4 isoenzyme [23]. These interactions may result in harmful effects for the patient due to the increased time of exposure to fentanyl, which may result in respiratory depression and skeletal muscle stiffness [4], [23].

Mitotane, used in Cushing's syndrome and adrenocortical carcinoma, belongs to the group of oral antineoplastics [24]–[27]. It is considered a drug that strongly induces CYP3A4 by activating SXR (steroid and xenobiotic receptor) [25]. Due to its strong activity on this enzyme complex, mitotane should be used with great caution, since it will affect the pharmacokinetics of other drugs, even after the cessation of its administration, this means that its strong activity on CYP3A4 is prolonged for months [26].

The data provided by Micromedex indicate that the interaction mechanism between the two drugs discussed in this point is related to the isoenzyme 3A4 of the CYP450 enzyme complex [15]. Considering the strong induction of CYP3A4 by mitotane and fentanyl being an inhibitor and a substrate of this isoenzyme, it is important to highlight the existence of drug interaction when these two drugs are administered concomitantly. In their study Kroiss et al. (2011) state that when mitotane is administered with this type of drug it will have an uncontrolled effect on them that may manifest itself in an increase in plasma concentration, in this case of mitotane, once fentanyl neutralizes the inducing effect of mitotane [24]. The opposite is also likely to be the case if the CYP3A4-inducing activity of fentanyl exceeds that of mitotane, in which case an increase in the plasma concentration of mitotane will be observed [24]. A reduction in plasma fentanyl concentrations is also possible, according to Micromedex, and may lead to severe respiratory depression, so monitoring and if necessary, discontinuation of mitotane should be undertaken [15].

### 4.3 Fentanyl-Cyclosporine

As previously mentioned, fentanyl is an opioid analgesic, which is one of the opioids most often involved in drug interactions [7].

Cyclosporine used to treat autoimmune diseases and prevent transplant rejection, is a potent immunosuppressant belonging to the group of oral antineoplastic agents. It is a lipophilic molecule that, after its administration and absorption, binds to P-glycoproteins [28]. The enzyme complex in the liver composed of the cytochrome P450 isoenzyme 3A4 is the main responsible for the reactions of N-methylation that degrade most of the molecule, the rest being metabolized in the gastrointestinal tract, through enzymes and intestinal flora [28]. However, factors such as age, patient status, or concomitant medication can affect the pharmacokinetics of cyclosporine, interfering with its metabolism [28].

Cyclosporine acts as an inhibitor of CYP3A4. That being said, when administered concomitantly with fentanyl, it may result in a decrease in the metabolism of the opioid analgesic and a consequent increase in its plasma concentration, leading to an increased risk of toxicity by the opioid. However, by decreasing the metabolism of fentanyl, there is an increase in the effectiveness of this drug, consequently, reactions such as sedation and respiratory depression may also occur [7], [15]. Another problem comes from withdrawal syndrome which manifests itself after discontinuing the administration of fentanyl, which although a small dose was administered, due to cyclosporine increasing its plasma concentration. For this reason, it is necessary to monitor the patient and reduce the opioid dose administered [15].

### 4.4 Morphine-Procarbazine

Morphine is a natural alkaloid, being the most commonly used opioid to treat moderate to severe pain [29], [30]. It is a total agonist of mu-opioid receptors and its effects are mainly related to them, such as analgesia, respiratory depression, reduced intestinal motility, nausea, and sedation [29]. It also binds, albeit to a lesser extent, to the kappa and delta receptors [29]. Morphine is almost completely absorbed in the gastrointestinal tract when administered orally and quickly distributed to tissues such as kidneys, lungs, and liver that are highly fused, mostly eliminated via the liver [29]. Due to the hepatic first-pass mechanism, only 20-30% of the dosage administered orally is available [29]. The conjugation with glucuronic acid results in two metabolites: morphine-6-glucuronide (M6G) and morphine-3-glucuronide (M3G) [29], [30]. Absorption by intramuscular administration is fast and total [29]. However, some factors influence absorption after intramuscular administration, for instance, site of application, pH of the injection site, tissue perfusion, and lipophilicity of the drug [31]. Having a short half-life, it should be administered every 4 hours [31].

When administered orally in repeated doses, morphine becomes very effective primarily as a result of the production of the active metabolite M6G during the first passage through the liver and being accumulated with successive administrations [31]. M6G binds to mu receptors and has greater analgesic potency than morphine [31]. Patients with impaired kidney function are more sensitive to morphine and may experience severe respiratory

depression [31]. Morphine blocks the transmission of nociceptive signals, activates signaling by pain-modulating neurons to the spinal cord, and inhibits the transmission of primary afferent nociceptors [30]. M3G has no analgesic activity and has a low affinity for opioid receptors [30].

Procarbazine, a monoamine oxidase inhibitor (MAO), has been used to treat Hodgkin's disease and brain tumors [32]. This active principle is a pro-drug whose transformation into azo-procarbazine is necessary to exert its action, and this transformation may occur in the liver or kidneys, through a reaction with molecular oxygen [33]. This transformation occurs very quickly when this drug is administered orally, having been reintroduced in the BEACOPP therapeutic regimen, composed by the association of this drug with bleomycin, etoposide, doxorubicin, vincristine, and prednisone [32].

Considering that morphine has depressive effects, essentially respiratory, and procarbazine is a MAO inhibitor and consequently a central nervous system depressant, the concomitant administration of these two drugs may be harmful to the patient's well-being, since it could result in the potentiation of the effects of morphine, resulting in respiratory depression, coma, deep sedation or hypotension, a result of decreased CYP450 activity by procarbazine [33], [34]. To avoid this situation, because the combination of these two drugs increases the risk of mortality, when compared to the isolated administration of each one, it is necessary to proceed with a 14-day spacing between taking each of them [34].

#### **4.5 Morphine-Cyclosporine**

As mentioned before, morphine is an alkaloid used to treat severe to moderated pain and cyclosporine is an immunosuppressant, used in oral antineoplastic therapy.

In accordance with Micromedex, concomitant use of morphine and cyclosporine can result in increased morphine exposure [15].

Cyclosporine is a P-glycoprotein inhibitor and inhibits the activity of the human blood-brain barrier P-glycoprotein [35]. By inhibiting P-glycoprotein, cyclosporine is blocking the entry of morphine into the brain, which reduces its action [35]. It can also lead to accumulation in the blood flow [35]. Also by inhibiting CYP3A4, cyclosporine inhibits the metabolism of morphine, causing an increase in adverse effects of morphine, such as miosis and respiratory depression [35]. Morphine at high concentrations can also cause anxiety, aphasia, and amnesia [15].

#### **4.6 Fentanyl-Tacrolimus**

As previously mentioned, fentanyl is a drug belonging to the pharmacotherapeutic group of opioid analgesics, used in the treatment of cancer-derived pain, whose metabolism is made by the isozyme CYP3A4 through a reaction called N-dealkylation [4], [21]–[23].

The tacrolimus is an antineoplastic agent with immunosuppressant action, used in organ transplantation for the prevention of rejection and the treatment of autoimmune diseases [36].



It can be found in different presentations, from injectables for intravenous administration to capsules for oral administration [36].

Considering its narrow therapeutic range, this drug must be carefully controlled when administered to avoid possible complications for patients, which also applies to potential drug interactions, since a blockage of its metabolism can be very harmful [36]. The metabolism of tacrolimus involves the liver isoenzymes, 3A4 and 3A5, of the CYP450 enzyme complex [36]. This process that occurs by 6b-hydroxylation gives rise to the active metabolite of tacrolimus called mono-demethylated [36].

The concomitant use of drugs also metabolized by these enzymes may result in a decrease in the effects of tacrolimus, which may result in transplant rejection in the patient [36]. After its metabolism, most of the elimination of tacrolimus occurs via bile or feces [36].

The treatment with oral antineoplastic agents, in this case, tacrolimus, has several side effects, one of which is oral and nasopharyngeal mucositis, which is the source of the pain associated with cancer treatment [37]. Bearing in mind that fentanyl has fewer adverse effects than drugs belonging to the same group, it has become the first choice in the maintenance of cancer-associated pain, therefore the concomitant administration of fentanyl and tacrolimus has become a recurrent practice in combating pain derived from the adverse effects of the antineoplastic [37].

As previously mentioned, both fentanyl and tacrolimus have a metabolism that passes through the P450 enzyme complex, more specifically through the 3A4 isoenzyme. When these two drugs are administered concomitantly, they will compete for this isoenzyme to be metabolized, and the one with the greatest affinity will be metabolized first. Since these two drugs are classified by the FDA (Food and Drug Administration) as having a narrow therapeutic window, this problem becomes important due to the effects that this interaction may have [37]. In a study by Kitazawa et al (2017) that aimed to determine the existence of drug interaction between fentanyl and tacrolimus, it was shown that when administered concomitantly there is a 46,9% decrease in tacrolimus clearance, which means the increase in blood concentration with the possibility of reaching toxic levels [37].

The biggest limitation of the present study was finding documentation related to the studied interactions, which proves the lack of information existent about this theme and highlights the existing need for more research.

## 5 Conclusion

Monitoring of possible drug-drug interactions in cancer patients is becoming more and more pertinent with the increasing use of oral antineoplastic agents. Cancer patients are usually polymedicated due to comorbidities. It would be important to raise awareness on the part of the prescribing doctors so that they were more careful when prescribing opioid analgesics to patients undergoing cancer treatment, often having to analyze the risk-benefit of the treatment.

As demonstrated in this study, most of the interactions studied are related to cytochrome P450 and its enzymes. It is possible to conclude that all interactions described are classified as pharmacokinetic, related to the metabolism and distribution of the drugs involved, except for the interaction between morphine and procarbazine which represents a synergism, therefore it is pharmacodynamic.

Since the interactions found were in the highest classification levels in terms of severity allow to conclude about the concern regarding the occurrence of these interactions and the importance of greater pharmacovigilance.

In this study, the proposed objectives were achieved, with twenty-three interactions found.

In future perspectives, it would be important to investigate the remaining drug interactions taken from the Micromedex database and quantify the frequency in which they occur.

## References

- [1] M. Ismail *et al.*, “Prevalence and significance of potential drug-drug interactions among cancer patients receiving chemotherapy,” *BMC Cancer*, vol. 20, no. 1, pp. 1–9, 2020, doi: 10.1186/s12885-020-06855-9.
- [2] M. Sharma *et al.*, “Clinical outcomes associated with drug–drug interactions of oral chemotherapeutic agents: a comprehensive evidence-based literature review,” *Drugs and Aging*, vol. 36, no. 4, pp. 341–354, 2019, doi: 10.1007/s40266-019-00640-5.
- [3] S. H. Kim, Y. Suh, Y. M. Ah, K. Jun, and J. Y. Lee, “Real-world prevalence of potential drug-drug interactions involving oral antineoplastic agents: a population-based study,” *Support. Care Cancer*, vol. 28, no. 8, pp. 3617–3626, 2019, doi: 10.1007/s00520-019-05204-2.
- [4] S. Guimarães, D. Moura, and P. S. da Silva, *Terapêutica medicamentosa e suas bases farmacológicas*, 6ªEdição. Porto Editora, 2014.
- [5] S. Goodin, “Oral chemotherapeutic agents: understanding mechanisms of action and drug interactions,” *Am. J. Heal. Pharm.*, vol. 64, no. Suppl 5, pp. S15–24, 2007, doi: 10.2146/ajhp070034.
- [6] M. Bennett, J. A. Paice, and M. Wallace, “Pain and opioids in cancer care: benefits, risks, and alternatives,” *Am. Soc. Clin. Oncol. Educ. B.*, vol. 37, pp. 705–713, 2017, doi: 10.14694/edbk\_180469.
- [7] A. Kotlinska-Lemieszek, P. Klepstad, and D. F. Haugen, “Clinically significant drug–drug interactions involving opioid analgesics used for pain treatment in patients with cancer: a systematic review,” *Drug Des. Devel. Ther.*, vol. 9, pp. 5255–5267, 2015, doi: 10.2147/DDDT.S86983.

- 
- [8] A. M. Trescot, S. Datta, M. Lee, and H. Hansen, "Opioid pharmacology," *Pain Physician J.*, vol. 11, no. Suppl 2, pp. S133-153, 2008.
- [9] E. Bruera and J. A. Paice, "Cancer pain management: safe and effective use of opioids," *Am. Soc. Clin. Oncol. Educ. B.*, vol. 35, pp. e593-599, 2015, doi: 10.14694/edbook\_am.2015.35.e593.
- [10] H. S. Smith, "Opioid metabolism," *Mayo Clin. Proc.*, vol. 84, no. 7, pp. 613-624, 2009, doi: 10.1016/S0025-6196(11)60750-7.
- [11] R. W. F. van Leeuwen *et al.*, "Prevalence of potential drug-drug interactions in cancer patients treated with oral anticancer drugs," *Br. J. Cancer*, vol. 108, no. 5, pp. 1071-1078, 2013, doi: 10.1038/bjc.2013.48.
- [12] E. Carcelero, H. Anglada, M. Tuset, and N. Creus, "Interactions between oral antineoplastic agents and concomitant medication: a systematic review," *Expert Opin. Drug Saf.*, vol. 12, no. 3, pp. 403-420, 2013, doi: 10.1517/14740338.2013.784268.
- [13] T. Lynch and A. Price, "The effect of cytochrome P450 metabolism on drug response, interactions, and adverse effects," *Am. Fam. Physician*, vol. 76, no. 3, pp. 391-396, 2007.
- [14] P. Gallo *et al.*, "Drug-drug interactions involving CYP3A4 and p-glycoprotein in hospitalized elderly patients," *Eur. J. Intern. Med.*, vol. 65, pp. 51-57, 2019, doi: 10.1016/j.ejim.2019.05.002.
- [15] IBM Corporation, "Drug interactions," *IBM Micromedex*, 2020. [https://www.micromedexsolutions.com/micromedex2/librarian/CS/B60825/ND\\_PR/evidencexpert/ND\\_P/evidencexpert/DUPLICATIONSHIELDSYNC/B18986/ND\\_PG/evidencexpert/ND\\_B/evidencexpert/ND\\_AppProduct/evidencexpert/ND\\_T/evidencexpert/PFActionId/evidencexpert.FindDrug](https://www.micromedexsolutions.com/micromedex2/librarian/CS/B60825/ND_PR/evidencexpert/ND_P/evidencexpert/DUPLICATIONSHIELDSYNC/B18986/ND_PG/evidencexpert/ND_B/evidencexpert/ND_AppProduct/evidencexpert/ND_T/evidencexpert/PFActionId/evidencexpert.FindDrug) (accessed Apr. 20, 2020).
- [16] A. Elkader and B. Sproule, "Clinical pharmacokinetics in the treatment of opioid dependence," *Clin. Pharmacokinet.*, vol. 44, no. 7, pp. 661-680, 2005, doi: 10.2165/00003088-199427020-00006.
- [17] M. P. Davis, G. Pasternak, and B. Behm, "Treating chronic pain: an overview of clinical studies centered on the buprenorphine option," *Drugs*, vol. 78, no. 12, pp. 1211-1228, 2018, doi: 10.1007/s40265-018-0953-z.
- [18] A. Haouala, N. Widmer, M. A. Duchosal, M. Montemurro, T. Buclin, and L. A. Decosterd, "Drug interactions with the tyrosine kinase inhibitors imatinib, dasatinib, and nilotinib," *Blood*, vol. 117, no. 8, pp. e75-87, 2011, doi: 10.1182/blood-2010-07-294330.
- [19] B. Peng, P. Lloyd, and H. Schran, "Clinical pharmacokinetics of imatinib," *Clin. Pharmacokinet.*, vol. 44, no. 9, pp. 879-894, 2005, doi: 10.2165/00003088-200544090-00001.

- 
- [20] I. Récoché *et al.*, “Drug-drug interactions with imatinib: an observational study,” *Medicine (Baltimore)*., vol. 95, no. 40, p. e5076, 2016, doi: 10.1097/MD.0000000000005076.
- [21] N. Parikh, V. Goskonda, A. Chavan, and L. Dillaha, “Single-dose pharmacokinetics of fentanyl sublingual spray and oral transmucosal fentanyl citrate in healthy volunteers: a randomized crossover study,” *Clin. Ther.*, vol. 35, no. 3, pp. 236–243, 2013, doi: 10.1016/j.clinthera.2013.02.017.
- [22] J. Scholz, M. Steinfath, and M. Schulz, “Clinical pharmacokinetics of alfentanil, fentanyl and sufentanil: an update,” *Clin. Pharmacokinet.*, vol. 31, no. 4, pp. 275–292, 1996, doi: 10.2165/00003088-199631040-00004.
- [23] S. A. Schug and S. Ting, “Fentanyl formulations in the management of pain: an update,” *Drugs*, vol. 77, no. 7, pp. 747–763, 2017, doi: 10.1007/s40265-017-0727-z.
- [24] M. Kroiss, M. Quinkler, W. K. Lutz, B. Alloio, and M. Fassnacht, “Drug interactions with mitotane by induction of CYP3A4 metabolism in the clinical management of adrenocortical carcinoma,” *Clin. Endocrinol. (Oxf)*., vol. 75, no. 5, pp. 585–591, 2011, doi: 10.1111/j.1365-2265.2011.04214.x.
- [25] A. Takeshita, J. Igarashi-Migitaka, N. Koibuchi, and Y. Takeuchi, “Mitotane induces CYP3A4 expression via activation of the steroid and xenobiotic receptor,” *J. Endocrinol.*, vol. 216, no. 3, pp. 297–305, 2013, doi: 10.1530/JOE-12-0297.
- [26] N. P. van Erp, H. J. Guchelaar, B. A. Ploeger, J. A. Romijn, J. Den Hartigh, and H. Gelderblom, “Mitotane has a strong and a durable inducing effect on CYP3A4 activity,” *Eur. J. Endocrinol.*, vol. 164, no. 4, pp. 621–626, 2011, doi: 10.1530/EJE-10-0956.
- [27] U. Waszut, P. Szyszka, and D. Dworakowska, “Understanding mitotane mode of action,” *J. Physiol. Pharmacol.*, vol. 68, no. 1, pp. 13–26, 2017.
- [28] A. Fahr, “Cyclosporin clinical pharmacokinetics,” *Clin. Pharmacokinet.*, vol. 24, no. 6, pp. 472–495, 1993, doi: 10.2165/00003088-199324060-00004.
- [29] E. Sverrisdóttir, T. M. Lund, A. E. Olesen, A. M. Drewes, L. L. Christrup, and M. Kreilgaard, “A review of morphine and morphine-6-glucuronide’s pharmacokinetic-pharmacodynamic relationships in experimental and clinical pain,” *Eur. J. Pharm. Sci.*, vol. 74, pp. 45–62, 2015, doi: 10.1016/j.ejps.2015.03.020.
- [30] L. L. Christrup, “Morphine metabolites,” *Acta Anaesthesiol. Scand.*, vol. 41, no. 1 II, pp. 116–122, 1997, doi: 10.1111/j.1399-6576.1997.tb04625.x.
- [31] R. A. Lugo and S. E. Kern, “Clinical pharmacokinetics of morphine,” *J. Pain Palliat. Care Pharmacother.*, vol. 16, no. 4, pp. 5–18, 2002, [Online]. Available: [http://journals.lww.com/drug-monitoring/Abstract/1991/01000/Clinical\\_Pharmacokinetics\\_of\\_Morphine.1.aspx](http://journals.lww.com/drug-monitoring/Abstract/1991/01000/Clinical_Pharmacokinetics_of_Morphine.1.aspx).

- 
- [32] R. Preiss, F. Baumann, R. Regenthal, and M. Matthias, "Plasma kinetics of procarbazine and azo-procarbazine in humans," *Anticancer. Drugs*, vol. 17, no. 1, pp. 75–80, 2006, doi: 10.1097/01.cad.0000181591.85476.aa.
- [33] R. Goerne, U. Bogdahn, and P. Hau, "Procarbazine – a traditional drug in the treatment of malignant gliomas," *Curr. Med. Chem.*, vol. 15, no. 14, pp. 1376–1387, 2008, doi: 10.2174/092986708784567707.
- [34] New Zealand Data Sheet, "Data Sheet of RA-MORPH," 1992.
- [35] K. Meissner, M. J. Avram, V. Yermolenka, A. M. Francis, J. Blood, and E. D. Kharasch, "Cyclosporine-inhibitable blood-brain barrier drug transport influences clinical morphine pharmacodynamics," *Anesthesiology*, vol. 119, no. 4, pp. 941–953, 2013, doi: 10.1097/ALN.0b013e3182a05bd3.
- [36] K. Iwasaki, "Metabolism of tacrolimus (FK506) and recent topics in clinical pharmacokinetics," *Drug Metab. Pharmacokinet.*, vol. 22, no. 5, pp. 328–335, 2007, doi: 10.2133/dmpk.22.328.
- [37] F. Kitazawa *et al.*, "Pharmacokinetic interaction between tacrolimus and fentanyl in patients receiving allogeneic hematopoietic stem cell transplantation," *Ann. Transplant.*, vol. 22, pp. 575–580, 2017, doi: 10.12659/AOT.904505.



# Potentially Irritant Preservatives in Newborn Baby Cosmetics – Analysis of Labels of Products Sold in Portugal

Diana F G Pinto<sup>1\*</sup>, Mariana J P Coelho<sup>1</sup>, Marisa F C Machado<sup>1</sup>,  
Agostinho L S Cruz<sup>1,2</sup>, Fernando X F Moreira<sup>1,2</sup>

<sup>1</sup> Escola Superior de Saúde (ESS), Instituto Politécnico do Porto (IPP), Porto, Portugal  
{dianapinto45, marianacoelho2606}@gmail.com, marisa\_cmachado@hotmail.com

<sup>2</sup> Centro de Investigação em Saúde e Ambiente (CISA), Escola Superior de Saúde (ESS),  
Instituto Politécnico do Porto (IPP), Porto, Portugal  
{agostinhocruz, ffm}@ess.ipp.pt

\*Diana F G Pinto, Mariana J P Coelho and Marisa F C Machado should be considered joint first author

**Abstract.** *The use of cosmetics containing preservatives might pose a risk to the skin health of newborns, despite improving their adaptation to the external environment. The present work aimed at depicting the potentially hazardous preservatives in cosmetics sold in the district of Porto, Portugal. A total of 281 labels from newborn cosmetics were analyzed. From 729 different ingredients found in the analyzed labels, 15 were preservatives with previously recorded irritant activity, being sodium benzoate the most mentioned ( $n = 118$ ). There was a significant difference between the means of number of preservatives with an irritant potential present in the products sold in pharmacies and in the products sold in supermarkets. Most analyzed products contained at least one preservative. Still, the choice of cosmetics for newborns should consider those with a minimum number of preservatives, being more probable to choose a less sensitizing product in pharmacies than in supermarkets.*

**Keywords.** Preservatives, cosmetics, allergic contact dermatitis, irritant contact dermatitis, labels

## 1 Introduction

Despite the similarities between the thickness and lipid composition of neonatal epidermis of full-term infants and the epidermis of adults, there are several differences regarding morphological and functional features, which are accentuated in the case of preterm infants. Indeed, even in full-term babies, the pH is more alkaline [1-3], stratum corneum moisturization is deficient in the first days [1, 4], the capillary system is not fully formed [5, 6], and the production of sebum is inferior to that of adults (except for the first week in which it reaches its peak) [7, 8]. Several factors can influence the process of gradual adaptation to the external environment, especially the weather conditions, the use of diapers and the application of cosmetics [9].

The use of cosmetics may be important in the transition from the humid uterine environment to a dry atmosphere where it is necessary to ensure not only the correct development but also to protect the skin from possible irritations and inflammation and to create a feeling of comfort. In full term babies, the use of cleansers, mild surfactants and cosmetic products with a high percentage of water is considered appropriate and both newborns and young children have a good tolerance towards them [10, 11]. Additionally, the use of creams and emollients are considered beneficial in the recovery of the skin barrier function, for example in the case of irritant dermatitis in the diaper area, contributing significantly to a lower transepidermal water loss [11, 12].

Despite the benefits of the application of cosmetics in newborns, it is generally recognized that the formulations of the products used in this population group may present potentially irritant and harmful substances [13]. Thus, the evaluation of cosmetic formulations should be done carefully both by parents and by health professionals, being the information on the label the most accessible resource for this purpose. On the label, the presentation of the ingredients is obligatory and the presence of one or more preservatives (defined as substances whose main or exclusive purpose is the inhibition of microbial growth in the cosmetic product) is frequent [14].

Due to the potential adverse effects of the application of cosmetics in newborn babies, the present study aims to evaluate the prevalence of potentially hazardous preservatives in cosmetics and body hygiene products sold in pharmacies and supermarkets in the district of Porto, Portugal.

## 2 Methodology

The present cross-sectional study was based on the analysis of the labels of cosmetic and body hygiene products intended for newborns. The non-probability sampling allowed the inclusion of products sold in pharmacies and supermarkets located in the district of Porto (Portugal), in the period between November 2017 and January 2018, ultimately leading to the analysis of 281 product labels.



All included labels were characterized regarding their ingredients, intended function (cologne and perfumes, leave-on cleansers, rinse-off cleansers, diaper area creams, moisturizing products, sunscreens and other), origin (national or international) and place of sale (pharmacy or supermarket).

In parallel, a search was performed through Pubmed, regarding all the preservatives present in the labels, according to their “International Nomenclature of Cosmetic Ingredients” (INCI) designation. The case studies reporting allergic or hypersensitivity reactions resulting from the application to the skin or scalp of a particular preservative present in a cosmetic or body care product published until 2018 were considered for the identification of the preservatives with the greatest potential to cause an irritant effect. Studies reporting adverse effects from a non-transdermal route of administration (i.e. oral, intravenous, etc.) were excluded, as well as those reporting reactions resulting from the application of non-cosmetic products (such as paints, medical devices, etc.).

The statistical tool Statistical Package for the Social Sciences (SPSS) (version 25) was used for the purposes of registration and systematization of data. Student's t-test was applied and a p-value  $<0.05$  was considered statistically significant.

### 3 Results

The present study resulted in the analysis of 151 products commercialized in pharmacies and 130 products sold in supermarkets. From 729 different ingredients found in the analyzed labels, 28 are classified as preservatives, according to the Regulation (EC) Number 1223/2009 of the European Parliament and of the Council of 30 November 2009 [14]. There were 81 products (29%) that had no preservatives in their composition, while 200 products (71%) had at least one preservative.

Fifteen preservatives deserved special attention throughout the present work owing to the attribution of hypersensitive effects due to their presence in cosmetics applied directly to the skin or scalp in previously published case studies: phenoxyethanol, benzyl alcohol, parabens, polyaminopropyl biguanide, chlorhexidine digluconate, diazolidinyl urea, imidazolidinyl urea, 2-bromo-2-nitropropane-1,3-diol, chlorphenesin, iodopropynil butylcarbamate, methylchlorisothiazolinone, methylisothiazolinone, sodium benzoate, sodium metabisulfite and sorbic acid (Table 1). Of these 15 preservatives, the most commonly mentioned in the labels of the analyzed products are sodium benzoate ( $n = 118$ ), phenoxyethanol ( $n = 62$ ), sorbic acid ( $n = 23$ ), parabens ( $n = 16$ ) and benzyl alcohol.

Table 1. Case reports of hypersensitivity reactions to preservatives following cosmetics application on skin or hair

Others	Sorbic Acid								
	Sodium Metabisulfite								[73-75] [76-80]
	Sodium Benzoate								[72]
Izothiazoline derivatives	Methyl-isothiazolinone		[51, 52]						[62-71]
	Methylchloro-isothiazolinone		[51]	[51, 52]	[51-54]				[62-67]
Halogenated	Iodopropynil Butylcarbamate								[59-61]
	Chlorphenesin								[56-58]
	2-Bromo-2-Nitropropane-1,3-diol								[55]
Formaldehyde-releasing preservatives	Imidazolidinyl Urea					[20]			[47-49]
	Diazolidinyl Urea					[20]			[43-47] [50]
Diquanides	Chlorhexidine Digluconate	[16]	[17]			[19]			[39-42]
	Polyaminopropyl Biguanide								[36-38]
Derivates of phydroxy-benzoic acid	Parabens	[15]							[28, 31-35]
Alcohols	Benzyl Alcohol								[26-30]
	Phenoxyethanol				[18]				[21-25]
		Case Reports in neonates and infants (0-2 years old)							
		Case Reports in Young Child (2-6 years old)							
		Case Reports in Child (7-11 years old)							
		Case Reports in Adolescents (12-18 years old)							
		Case Reports in Adults							
		Patients Age not mentioned							

Concerning the number and types of preservatives presented by the product labels, there is a highly variable distribution, especially regarding the preservatives used in leave-on and rinse-off cleansers, diaper area creams and moisturizing products, all of them presenting 5 or more types of compounds (Figure 1). Nevertheless, these are the products that present a larger number of units in the present sample, which may justify the variability found. Sun protection products, colognes and perfumes and other products have 4 or fewer types of preservatives but only represent 32 products of the final sample (Figure 1 and Table 2).

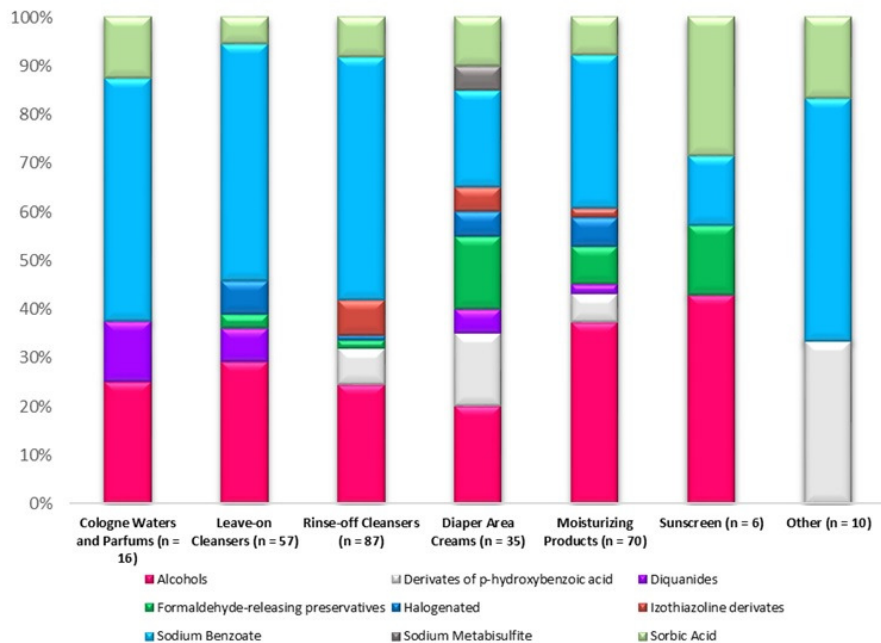

**Figure 1.** Relative frequencies of analyzed preservatives in skin care and cosmetic product for babies, in Portugal

**Table 2.** Absolut frequencies of products per category and number of preservatives in each group

Category	Cologne waters and parfums	Leave-on cleansers	Rinse-off cleansers	Diaper area creams	Moisturizing products	Sunscreen	Other
Total of products (n)	16	57	87	35	70	6	10
Mean of targeted conservatives ± standard deviation	0.6 ± 0.7	1.3 ± 0.7	1.3 ± 1.4	0.6 ± 0.9	0.7 ± 1.0	1.3 ± 1.5	0.6 ± 1.0

Sunscreen products, leave-on cleansers and rinse-off cleansers have the highest average number of preservatives with irritant potential, whereas moisturizing products, cologne and perfumes, diaper area creams and other products are those with a lower average of preservatives with sensitizing potential in their composition (Table 2).

The comparison of the preservatives identified as potentially irritant in the products sold in pharmacies with those present in the products sold in supermarkets showed a notable difference (Figure 2). Using the t-test, it was demonstrated that there is a statistically significant difference between the mean number of preservatives with an irritant potential present in the cosmetic and body hygiene products for newborns sold in pharmacies ( $1.01 \pm 1.358$ ) and the mean number of preservatives with an irritant potential present in the cosmetic and body hygiene products for newborns sold in supermarkets ( $1.55 \pm 1.114$ ).

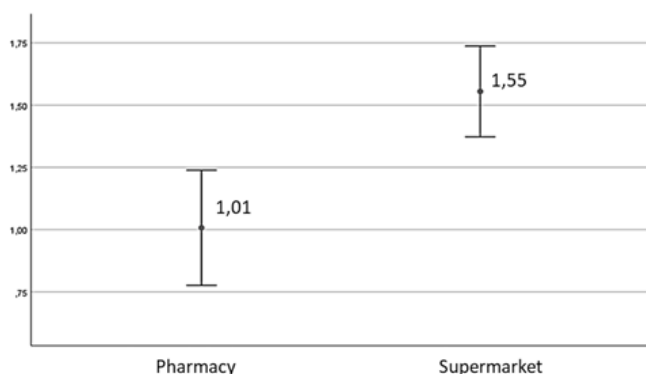

**Figure 2.** 95% Confidence intervals and average of the number of potentially irritant preservatives in cosmetics sold in Portugal

The observed difference between the average number of potentially irritant preservatives in cosmetics sold in pharmacies and in supermarkets does not seem to be influenced by the categories of the products. In fact, a slightly higher number of the products belonging to the categories in which a higher mean of potentially irritant preservatives is more likely (leave-one cleansers, rinse-off cleansers and sunscreens, according to table 2) were analyzed from pharmacies, than from supermarkets (Table 3).

**Table 3.** Absolut frequencies of products commercialized in pharmacies and supermarkets, per category

Categories of products	Pharmacy	Supermarket	Total
Cologne waters and parfums	7	9	16
Leave-on cleansers	30	27	57
Rinse-off cleansers	45	42	87
Diaper area creams	22	13	35
Moisturizing products	35	35	70
Sunscreen	4	2	6
Other	8	2	10
<b>Total</b>	<b>151</b>	<b>130</b>	<b>281</b>

As regards to the comparison of the mean number of potentially irritant preservatives in products produced in Portugal and products produced in other countries, there is no statistically significant difference ( $p > 0.05$ ). Cosmetic and body hygiene products produced in Portugal have an approximate mean of one potentially irritant preservative in their composition ( $0.98 \pm 1.30$ ), as well as imported products ( $0.97 \pm 1.03$ ). Therefore, it can be assumed that the tendency for the inclusion of potentially irritant preservatives in Portugal is similar to the tendency of the other countries, being the leave-on and the rinse-off cleansers the categories of products with the highest number of potentially irritant preservatives.

## 4 Discussion and Conclusion

Most of the analyzed products in the present study have preservatives in their composition. This result might be justified by the fact that the presence of microorganisms in cosmetics and body hygiene products may change their composition, possibly resulting in irritations and infections, especially when these products are applied in injured skin, in the skin area surrounding the eyes or in baby skin [81-83]. Pathogenic strains of *Staphylococcus aureus* and *Pseudomonas aeruginosa* are amongst the microorganisms most frequently identified in cosmetic products, [83] and cases of hospitalization of individuals due to the use of contaminated cosmetics, namely by bacteria *Burkholderia cepacia*, have already been reported [84, 85]. However, contrary to what was described in a similar study performed in Bangkok, where all cosmetic products contained preservatives in their composition [86], the preservatives are absent in a substantial number of products. This result can be justified by the fact that, contrary to the mentioned study, all the analyzed products are intended to be applied in newborns and can frequently cause undesirable side effects. Indeed, it is estimated that approximately 6% of the population is allergic to preservatives and fragrances, the two main groups of compounds responsible for hypersensitivity reactions in cosmetics [87, 88]. Particularly as regards to the preservatives identified in the analyzed labels, parabens, formaldehyde-releasing preservatives (diazolidinyl urea, imidazolidinyl urea and 2-bromo-2-nitropropane-1,3-diol) and methylisothiazolinone were already linked to negative effects in clinical trials. Butylparaben and propylparaben revealed a significant increase in the likelihood of allergen sensitization [89] and in vitro studies about the activity of parabens demonstrated the induction of phenotypic transformations in breast epithelial cells [90], increased proliferation, migration and acquisition of invasive properties of cancer cells [91, 92] and the generation of reactive oxygen species and DNA damage in spermatozoa [93], hence confirming the estrogenic, anti-androgenic and genotoxic potential of the parabens. It is noteworthy that the presence of propylparaben in a product for application in the diaper area violates the Regulation (EU) No 1004/2014 (that amends the Annex V to Regulation (EC) No 1223/2009 of the European Parliament and of the Council on cosmetic products), that states that “butylparaben and propylparaben should be prohibited in leave-on cosmetic products designed for application on the nappy area of children below three years.” [94]. Concerning formaldehyde-releasing compounds, they have already caused contact allergies in humans [95] and particularly methylisothiazolinone gave rise to in vitro neurotoxicity effects [96, 97].

According to the Commission Regulation (EU) 2017/1224 of 6 July 2017 amending Annex V to Regulation (EC) No 1223/2009 of the European Parliament and of the Council on cosmetic products, methylisothiazolinone “should (...) be further restricted in rinse-off products”. Additionally, it is acknowledged that, in non-rinsed cosmetic products, it has not been yet demonstrated any safe concentrations of methylisothiazolinone, regarding the elicitation of contact allergies [98]. In the studied sample, one product intended to be used as a diaper area cream and one body moisturizer product presented methylisothiazolinone in their composition as well as four rinse-off cleansers.

The inclusion of a greater number of potentially irritating preservatives in cosmetics and body hygiene products intended for newborns marketed in hypermarkets than in pharmacies may result in hypersensitization more frequently [99]. Additionally, the use of various cosmetics or body care products containing the same preservative necessarily increases the risk of sensitization due to repeated exposure [100]. For example, studies regarding the use of cosmetic products in French children (0-3 years old) [101] and Portuguese children (0-5 years old) showed that, on average, six cosmetic products are applied daily. The cumulative potential for causing hypersensitivity reactions in infants exposed to a high number of cosmetics is thus evident, and particularly if they are leave-on products rather than rinse-off products, since those stay in contact with the cutaneous surface for longer periods.

In order to ensure a better adaptation of the skin and its annexes to the outside environment by newborns and infants, the use of cosmetics is undeniably pertinent. However, the inclusion of preservatives in a balanced manner in these products is imperative and the minimum number of preservatives required to ensure the preservation of products must be used in order to avoid excessive exposure to these compounds with a recognized sensitizing potential. Regulating authorities play a central role in market surveillance and should ensure that only legally permitted preservatives are present in marketed cosmetic products.

## References

- [1] Hoeger, P.H. and C.C. Enzmann, Skin physiology of the neonate and young infant: a prospective study of functional skin parameters during early infancy. *Pediatr Dermatol*, 2002. 19(3): p. 256-62.
- [2] Fox, C., D. Nelson, and J. Wareham, The timing of skin acidification in very low birth weight infants. *J Perinatol*, 1998. 18(4): p. 272-5.
- [3] Green, M., B. Carol, and H. Behrendt, Physiologic skin pH patterns in infants of low birth weight. The onset of surface acidification. *Am J Dis Child*, 1968. 115(1): p. 9-16.
- [4] Yosipovitch, G., A. Maayan-Metzger, P. Merlob, and L. Sirota, Skin barrier properties in different body areas in neonates. *Pediatrics*, 2000. 106(1 Pt 1): p. 105-8.

- 
- [5] Takayanagi, T., M. Fukuda, M. Nakazawa, S. Tanaka, and M. Yoshinaga, Response of skin blood volume, velocity and flow to local warming in newborns, measured by laser Doppler flowmetry. *Pediatr Int*, 1999. 41(6): p. 624-30.
- [6] Fluhr, J.W., R. Darlenski, A. Taieb, J.P. Hachem, C. Baudouin, P. Msika, C. De Belilovsky, and E. Berardesca, Functional skin adaptation in infancy - almost complete but not fully competent. *Exp Dermatol*, 2010. 19(6): p. 483-92.
- [7] Agache, P., D. Blanc, C. Barrant, and R. Laurent, Sebum levels during the first year of life. *Br J Dermatol*, 1980. 103(6): p. 643-9.
- [8] Henderson, C.A., J. Taylor, and W.J. Cunliffe, Sebum excretion rates in mothers and neonates. *Br J Dermatol*, 2000. 142(1): p. 110-1.
- [9] Ramos-e-Silva, M., J.C. Boza, and T.F. Cestari, Effects of age (neonates and elderly) on skin barrier function. *Clin Dermatol*, 2012. 30(3): p. 274-6.
- [10] Blume-Peytavi, U., M. Hauser, G.N. Stamatas, D. Pathirana, and N. Garcia Bartels, Skin care practices for newborns and infants: review of the clinical evidence for best practices. *Pediatr Dermatol*, 2012. 29(1): p. 1-14.
- [11] Garcia Bartels, N., R. Scheufele, F. Prosch, T. Schink, H. Proquitte, R.R. Wauer, and U. Blume-Peytavi, Effect of standardized skin care regimens on neonatal skin barrier function in different body areas. *Pediatr Dermatol*, 2010. 27(1): p. 1-8.
- [12] Visscher, M.O., R. Adam, S. Brink, and M. Odio, Newborn infant skin: physiology, development, and care. *Clin Dermatol*, 2015. 33(3): p. 271-80.
- [13] Fernandes, J.D., M.C. Machado, and Z.N. Oliveira, Children and newborn skin care and prevention. *An Bras Dermatol*, 2011. 86(1): p. 102-10.
- [14] European Union, Regulation (EC) No 1223/2009 of the European Parliament and of the Council. 2009: Official Journal of the European Union.
- [15] Nardelli, A., M.A. Morren, and A. Goossens, Contact allergy to fragrances and parabens in an atopic baby. *Contact Dermatitis*, 2009. 60(2): p. 107-9.
- [16] Le Corre, Y., S. Barbarot, A.S. Frot, and B. Milpied, Allergic contact dermatitis to chlorhexidine in a very young child. *Pediatr Dermatol*, 2010. 27(5): p. 485-7.
- [17] de Waard-van der Spek, F.B. and A.P. Oranje, Allergic contact dermatitis to chlorhexidine and para-amino compounds in a 4-year-old boy: a very rare observation. *Contact Dermatitis*, 2008. 58(4): p. 239-41.
- [18] Birnie, A.J. and J.S. English, 2-phenoxyethanol-induced contact urticaria. *Contact Dermatitis*, 2006. 54(6): p. 349.
- [19] Thune, P., [Two patients with chlorhexidine allergy--anaphylactic reactions and eczema]. *Tidsskr Nor Laegeforen*, 1998. 118(21): p. 3295-6.

- [20] Garcia-Gavin, J., D. Gonzalez-Vilas, V. Fernandez-Redondo, and J. Toribo, Allergic contact dermatitis in a girl due to several cosmetics containing diazolidinyl-urea or imidazolidinyl-urea. *Contact Dermatitis*, 2010. 63(1): p. 49-50.
- [21] Hernandez, B., F.J. Ortiz-Frutos, M. Garcia, S. Palencia, M.C. Garcia, and L. Iglesias, Contact urticaria from 2-phenoxyethanol. *Contact Dermatitis*, 2002. 47(1): p. 54.
- [22] Bohn, S. and A.J. Bircher, Phenoxyethanol-induced urticaria. *Allergy*, 2001. 56(9): p. 922-3.
- [23] Lovell, C.R., I.R. White, and J. Boyle, Contact dermatitis from phenoxyethanol in aqueous cream BP. *Contact Dermatitis*, 1984. 11(3): p. 187.
- [24] Lujan, D., B. Hernandez-Machin, Y. Penate, and L. Borrego, Contact urticaria due to phenoxyethanol in an aftershave. *Dermatitis*, 2009. 20(4): p. E10.
- [25] Nunez Orjales, R., C. Carballas Vazquez, F. Carballada Gonzalez, and M. Boquete Paris, 2-phenoxyethanol-induced contact urticaria and anaphylaxis. *J Investig Allergol Clin Immunol*, 2010. 20(4): p. 354-5.
- [26] Jacob, S.E. and S. Stechschulte, Eyelid dermatitis associated with balsam of Peru constituents: benzoic acid and benzyl alcohol. *Contact Dermatitis*, 2008. 58(2): p. 111-2.
- [27] Mitchell, D.M. and M.H. Beck, Contact allergy to benzyl alcohol in a cutting oil reodorant. *Contact Dermatitis*, 1988. 18(5): p. 301-2.
- [28] Fisher, A.A., Allergic paraben and benzyl alcohol hypersensitivity relationship of the "delayed" and "immediate" varieties. *Contact Dermatitis*, 1975. 1(5): p. 281-4.
- [29] Curry, E.J. and E.M. Warshaw, Benzyl alcohol allergy: importance of patch testing with personal products. *Dermatitis*, 2005. 16(4): p. 203-8.
- [30] Li, M. and E. Gow, Benzyl alcohol allergy. *Australas J Dermatol*, 1995. 36(4): p. 219-20.
- [31] Simpson, J.R., Dermatitis due to parabens in cosmetic creams. *Contact Dermatitis*, 1978. 4(5): p. 311-2.
- [32] Oiso, N., K. Fukai, and M. Ishii, Allergic contact dermatitis caused by parabens in a compress. *Contact Dermatitis*, 2004. 50(5): p. 317.
- [33] Cooper, S.M. and S. Shaw, Allergic contact dermatitis from parabens in a tar shampoo. *Contact Dermatitis*, 1998. 39(3): p. 140.
- [34] Henry, J.C., E.H. Tschen, and L.E. Becker, Contact urticaria to parabens. *Arch Dermatol*, 1979. 115(10): p. 1231-2.
- [35] Mowad, C.M., Allergic contact dermatitis caused by parabens: 2 case reports and a review. *Am J Contact Dermat*, 2000. 11(1): p. 53-6.



- 
- [36] Creytens, K., A. Goossens, M. Faber, D. Ebo, and O. Aerts, Contact urticaria syndrome caused by polyaminopropyl biguanide in wipes for intimate hygiene. *Contact Dermatitis*, 2014. 71(5): p. 307-9.
- [37] Leysen, J., A. Goossens, J. Lambert, and O. Aerts, Polyhexamethylene biguanide is a relevant sensitizer in wet wipes. *Contact Dermatitis*, 2014. 70(5): p. 323-5.
- [38] Aerts, O., J. Smeets, K. Adriaenssens, J. Lambert, and A. Goossens, Contact allergy to biguanides might explain cases of unresolved eyelid dermatitis. *J Eur Acad Dermatol Venereol*, 2015. 29(10): p. 2064-5.
- [39] Toholka, R. and R. Nixon, Allergic contact dermatitis to chlorhexidine. *Australas J Dermatol*, 2013. 54(4): p. 303-6.
- [40] Wittczak, T., W. Dudek, J. Walusiak-Skorupa, D. Swierczynska-Machura, and C. Palczynski, Chlorhexidine--still an underestimated allergic hazard for health care professionals. *Occup Med (Lond)*, 2013. 63(4): p. 301-5.
- [41] Lauerma, A.I., Simultaneous immediate and delayed hypersensitivity to chlorhexidine digluconate. *Contact Dermatitis*, 2001. 44(1): p. 59.
- [42] Osmundsen, P.E., Contact dermatitis to chlorhexidine. *Contact Dermatitis*, 1982. 8(2): p. 81-3.
- [43] de Groot, A.C., D.P. Bruynzeel, B.A. Jagtman, and J.W. Weyland, Contact allergy to diazolidinyl urea (Germall II). *Contact Dermatitis*, 1988. 18(4): p. 202-5.
- [44] Kantor, G.R., J.S. Taylor, J.L. Ratz, and P.L. Evey, Acute allergic contact dermatitis from diazolidinyl urea (Germall II) in a hair gel. *J Am Acad Dermatol*, 1985. 13(1): p. 116-9.
- [45] Zaugg, T. and T. Hunziker, Germall II and triclosan. *Contact Dermatitis*, 1987. 17(4): p. 262.
- [46] Cahill, J.L. and R.L. Nixon, Allergic contact dermatitis in health care workers to diazolidinyl urea present in antimicrobial hand gel. *Med J Aust*, 2011. 194(12): p. 664-5.
- [47] Tosti, A., S. Restani, and M. Lanzarini, Contact sensitization to diazolidinyl urea: report of 3 cases. *Contact Dermatitis*, 1990. 22(2): p. 127-8.
- [48] Dooms-Goossens, A., K. de Boule, M. Dooms, and H. Degreef, Imidazolidinyl urea dermatitis. *Contact Dermatitis*, 1986. 14(5): p. 322-4.
- [49] de Groot, A.C. and J.W. Weyland, Hidden contact allergy to formaldehyde in imidazolidinyl urea. *Contact Dermatitis*, 1987. 17(2): p. 124-5.
- [50] Fisher, A.A., Allergic contact dermatitis from Germall 115, a new cosmetic preservative. *Contact Dermatitis*, 1975. 1(2): p. 126.

- [51] Quenan, S., P. Piletta, and A.M. Calza, Isothiazolinones: sensitizers not to miss in children. *Pediatr Dermatol*, 2015. 32(3): p. e86-8.
- [52] Chang, M.W. and R. Nakrani, Six children with allergic contact dermatitis to methylisothiazolinone in wet wipes (baby wipes). *Pediatrics*, 2014. 133(2): p. e434-8.
- [53] Admani, S., C. Matiz, and S.E. Jacob, Methylisothiazolinone: a case of perianal dermatitis caused by wet wipes and review of an emerging pediatric allergen. *Pediatr Dermatol*, 2014. 31(3): p. 350-2.
- [54] Khanna, S. and M. Reeder, Vesicular Hand Dermatitis in a Child: Allergy to Methylisothiazolinone. *Pediatr Dermatol*, 2016. 33(5): p. e272-3.
- [55] Storrs, F.J. and D.E. Bell, Allergic contact dermatitis to 2-bromo-2-nitropropane-1,3-diol in a hydrophilic ointment. *J Am Acad Dermatol*, 1983. 8(2): p. 157-70.
- [56] Dyring-Andersen, B., J. Elberling, J. Duus Johansen, and C. Zachariae, Contact allergy to chlorphenesin. *J Eur Acad Dermatol Venereol*, 2015. 29(5): p. 1019.
- [57] Brown, V.L. and D.I. Orton, Two cases of facial dermatitis due to chlorphenesin in cosmetics. *Contact Dermatitis*, 2005. 52(1): p. 48-9.
- [58] Wakelin, S.H. and I.R. White, Dermatitis from chlorphenesin in a facial cosmetic. *Contact Dermatitis*, 1997. 37(3): p. 138-9.
- [59] Toholka, R. and R. Nixon, Suspected allergic contact dermatitis to iodopropynyl butylcarbamate in an alcohol hand rub commonly used in Australian health-care settings. *Australas J Dermatol*, 2014. 55(1): p. 70-1.
- [60] Natkunarajah, J., V. Osborne, and C. Holden, Allergic contact dermatitis to iodopropynyl butylcarbamate found in a cosmetic cleansing wipe. *Contact Dermatitis*, 2008. 58(5): p. 316-7.
- [61] Schollnast, R., B. Kranke, and W. Aberer, [Anal and palmar contact dermatitis caused by iodopropynyl butylcarbamate in moist sanitary wipes]. *Hautarzt*, 2003. 54(10): p. 970-4.
- [62] Isaksson, M. and L. Persson, 'Mislabelled' make-up remover wet wipes as a cause of severe, recalcitrant facial eczema. *Contact Dermatitis*, 2015. 73(1): p. 56-9.
- [63] Kazandjieva, J., M. Gergovska, and R. Darlenski, Contact dermatitis in a child from methlychloroisothiazolinone and methylisothiazolinone in moist wipes. *Pediatr Dermatol*, 2014. 31(2): p. 225-7.
- [64] Timmermans, A., S. De Hertog, K. Gladys, H. Vanacker, and A. Goossens, 'Dermatologically tested' baby toilet tissues: a cause of allergic contact dermatitis in adults. *Contact Dermatitis*, 2007. 57(2): p. 97-9.

- 
- [65] Fernandez de Corres, L., J.A. Navarro, G. Gastaminza, and M.D. Del Pozo, An unusual case of sensitization to methylchloro- and methyl-isothiazolinone (MCI/MI). *Contact Dermatitis*, 1995. 33(3): p. 215-6.
- [66] Concha-Garzon, M.J., G. Solano-Lopez, A. Montes, J. Fraga, and J. Sanchez, Follicular allergic contact dermatitis due to methylchloroisothiazolinone/methylisothiazolinone (MCI/MI) in a rinse-off soap product. *Clin Exp Dermatol*, 2015. 40(6): p. 690-1.
- [67] Monroe, H.R., J.C. Hu, and M.W. Chiu, Methylchloroisothiazolinone / methylisothiazolinone and moist wipe dermatitis. *Dermatol Online J*, 2010. 16(5): p. 14.
- [68] Madsen, J.T., F. Andersen, and K.E. Andersen, Generalized allergic contact dermatitis caused by methylisothiazolinone in a spray tan. *Contact Dermatitis*, 2015. 73(3): p. 184-5.
- [69] Palmer, M.J. and R. Nixon, Polysensitisation in a laboratory scientist associated with allergic contact dermatitis from methylisothiazolinone in skin cleansers. *Australas J Dermatol*, 2015. 56(1): p. 56-8.
- [70] Hamann, C.R., N. Brankov, D. Hamann, and C. Hamann, Chronic areolar dermatitis due to methylisothiazolinone-containing bodywash. *Clin Exp Dermatol*, 2016. 41(1): p. 114-5.
- [71] Amaro, C., R. Santos, and J. Cardoso, Contact allergy to methylisothiazolinone in a deodorant. *Contact Dermatitis*, 2011. 64(5): p. 298-9.
- [72] Sutton, T. and R. Nixon, Allergic contact dermatitis to sodium benzoate chloroacetamide in a sorbolene lotion. *Australas J Dermatol*, 2006. 47(3): p. 209-10.
- [73] Malik, M.M., M.A. Hegarty, and J.F. Bourke, Sodium metabisulfite—a marker for cosmetic allergy? *Contact Dermatitis*, 2007. 56(4): p. 241-2.
- [74] Oliveira, A., C. Amaro, and J. Cardoso, Allergic contact dermatitis caused by sodium metabisulphite in a cosmetic bleaching cream. *Australas J Dermatol*, 2015. 56(2): p. 144-5.
- [75] Huang, P.Y. and C.Y. Chu, Allergic contact dermatitis due to sodium metabisulfite in a bleaching cream. *Contact Dermatitis*, 2007. 56(2): p. 123-4.
- [76] Dejobert, Y., E. Delaporte, F. Piette, and P. Thomas, Vesicular eczema and systemic contact dermatitis from sorbic acid. *Contact Dermatitis*, 2001. 45(5): p. 291.
- [77] Giordano-Labadie, F., C. Pech-Ormieres, and J. Bazex, Systemic contact dermatitis from sorbic acid. *Contact Dermatitis*, 1996. 34(1): p. 61-2.
- [78] Coyle, H.E., E. Miller, and R.S. Chapman, Sorbic acid sensitivity from Unguentum Merck. *Contact Dermatitis*, 1981. 7(1): p. 56-7.
- [79] Brown, R., Another case of sorbic acid sensitivity. *Contact Dermatitis*, 1979. 5(4): p. 268.

- [80] Rietschel, R.L., Contact urticaria from synthetic cassia oil and sorbic acid limited to the face. *Contact Dermatitis*, 1978. 4(6): p. 347-9.
- [81] Deza, G. and A.M. Gimenez-Arnau, Allergic contact dermatitis in preservatives: current standing and future options. *Curr Opin Allergy Clin Immunol*, 2017. 17(4): p. 263-268.
- [82] Horev, L., M. Isaksson, M. Engfeldt, L. Persson, A. Ingber, and M. Bruze, Preservatives in cosmetics in the Israeli market conform well to the EU legislation. *J Eur Acad Dermatol Venereol*, 2015. 29(4): p. 761-6.
- [83] Lundov, M.D., L. Moesby, C. Zachariae, and J.D. Johansen, Contamination versus preservation of cosmetics: a review on legislation, usage, infections, and contact allergy. *Contact Dermatitis*, 2009. 60(2): p. 70-8.
- [84] Alvarez-Lerma, F., E. Maull, R. Terradas, C. Segura, I. Planells, P. Coll, H. Knobel, and A. Vazquez, Moisturizing body milk as a reservoir of *Burkholderia cepacia*: outbreak of nosocomial infection in a multidisciplinary intensive care unit. *Crit Care*, 2008. 12(1): p. R10.
- [85] Molina-Cabrillana, J., M. Bolanos-Rivero, E.E. Alvarez-Leon, A.M. Martin Sanchez, M. Sanchez-Palacios, D. Alvarez, and J.A. Saez-Nieto, Intrinsically contaminated alcohol-free mouthwash implicated in a nosocomial outbreak of *Burkholderia cepacia* colonization and infection. *Infect Control Hosp Epidemiol*, 2006. 27(11): p. 1281-2.
- [86] Bunyavaree, M., P. Kasemsarn, and W. Boonchai, Cosmetic preservative labelling on the Thai market. *Contact Dermatitis*, 2016. 74(4): p. 217-21.
- [87] Gonzalez-Munoz, P., L. Conde-Salazar, and S. Vano-Galvan, Allergic contact dermatitis caused by cosmetic products. *Actas Dermosifiliogr*, 2014. 105(9): p. 822-32.
- [88] Alvarez-Rivera, G., M. Llompert, M. Lores, and C. Garcia-Jares, Chapter 9 - Preservatives in Cosmetics: Regulatory Aspects and Analytical Methods, in *Analysis of Cosmetic Products (Second Edition)*, A. Salvador and A. Chisvert, Editors. 2018, Elsevier: Boston. p. 175-224.
- [89] Savage, J.H., E.C. Matsui, R.A. Wood, and C.A. Keet, Urinary levels of triclosan and parabens are associated with aeroallergen and food sensitization. *J Allergy Clin Immunol*, 2012. 130(2): p. 453-60.e7.
- [90] Khanna, S. and P.D. Darbre, Parabens enable suspension growth of MCF-10A immortalized, non-transformed human breast epithelial cells. *J Appl Toxicol*, 2013. 33(5): p. 378-82.
- [91] Khanna, S., P.R. Dash, and P.D. Darbre, Exposure to parabens at the concentration of maximal proliferative response increases migratory and invasive activity of human breast cancer cells in vitro. *J Appl Toxicol*, 2014. 34(9): p. 1051-9.

- 
- [92] Charles, A.K. and P.D. Darbre, Combinations of parabens at concentrations measured in human breast tissue can increase proliferation of MCF-7 human breast cancer cells. *J Appl Toxicol*, 2013. 33(5): p. 390-8.
- [93] Samarasinghe, S., K. Krishnan, R. Naidu, M. Megharaj, K. Miller, B. Fraser, and R.J. Aitken, Parabens generate reactive oxygen species in human spermatozoa. *Andrology*, 2018.
- [94] European Union, Commission Regulation (EU) No 1004/2014 of 18 September 2014 amending Annex V to Regulation (EC) No 1223/2009 of the European Parliament and of the Council on cosmetic products Text with EEA relevance. 2014: Official Journal of the European Union
- [95] Lundov, M.D., J.D. Johansen, B.C. Carlsen, K. Engkilde, T. Menne, and J.P. Thyssen, Formaldehyde exposure and patterns of concomitant contact allergy to formaldehyde and formaldehyde-releasers. *Contact Dermatitis*, 2010. 63(1): p. 31-6.
- [96] Du, S., B. McLaughlin, S. Pal, and E. Aizenman, In vitro neurotoxicity of methylisothiazolinone, a commonly used industrial and household biocide, proceeds via a zinc and extracellular signal-regulated kinase mitogen-activated protein kinase-dependent pathway. *J Neurosci*, 2002. 22(17): p. 7408-16.
- [97] He, K., J. Huang, C.F. Lagenaur, and E. Aizenman, Methylisothiazolinone, a neurotoxic biocide, disrupts the association of SRC family tyrosine kinases with focal adhesion kinase in developing cortical neurons. *J Pharmacol Exp Ther*, 2006. 317(3): p. 1320-9.
- [98] European Union, Commission Regulation (EU) 2017/1224 of 6 July 2017 amending Annex V to Regulation (EC) No 1223/2009 of the European Parliament and of the Council on cosmetic products 2017: Official Journal of the European Union
- [99] Pastor-Nieto, M.A., F. Alcantara-Nicolas, V. Melgar-Molero, R. Perez-Mesonero, A. Vergara-Sanchez, A. Martin-Fuentes, P. Gonzalez-Munoz, and E. de Eusebio-Murillo, Preservatives in Personal Hygiene and Cosmetic Products, Topical Medications, and Household Cleaners in Spain. *Actas Dermosifiliogr*, 2017. 108(8): p. 758-770.
- [100] Gomez-Berrada, M.P., A.S. Ficheux, S. Guillou, C. Berge, D. de Javel, A.C. Roudot, and P.J. Ferret, Consumption and exposure assessment to cosmetic products for children under 2 years old. *Food Chem Toxicol*, 2017. 105: p. 151-160.
- [101] Ficheux, A.S., G. Chevillotte, N. Wesolek, T. Morisset, N. Dornic, A. Bernard, A. Bertho, A. Romanet, L. Leroy, A.C. Mercat, T. Creusot, E. Simon, and A.C. Roudot, Consumption of cosmetic products by the French population second part: Amount data. *Food Chem Toxicol*, 2016. 90: p. 130-41.



# **Student Contributions**





# Bringing VLC into ToF imaging: Pseudo-Passive Indoor ToF Imaging

Faisal Ahmed, Miguel Heredia Conde, Otmar Loffeld

Center for Sensorsystems (ZESS), University of Siegen, Paul-Bonatz-Str. 9-11, 57076  
Siegen, Germany  
{faisal.ahmed, heredia, loffeld}@zess.uni-siegen.de

**Abstract.** *High power consumption is a fundamental problem in active Time-of-Flight (ToF) modalities in contrast with passive imaging modalities, particularly when the ToF camera is incorporated into low-power devices, i.e., smartphones. This work introduces a novel concept that provides ToF-based measurements of a scene by empowering the light-based communication infrastructure in bistatic configuration. This provides a potential platform due to the pervasive presence of modulated light sources in indoor infrastructure. In this context, we are attempting to use VLC infrastructure, which synergistically supports lighting and communication, as an opportunity illuminator to attain ToF sensing for free. Such capabilities are demonstrated by performing simulations based on continuous-wave (CW) ToF and pulse-based (PB) ToF sensing in a passive approach. The passive modality not only makes the need for illumination units futile in ToF cameras, but also, consequently, will reduce the power consumption and cost of the system.*

**Keywords.** Passive sensing, visible light communication, OpenVLC, Time-of-Flight, bistatic, adaptive thresholding

## 1 Introduction

Over the past few years, 3D Time-of-Flight (ToF) imaging has evolved significantly and attracted the attention of both industry and academia researchers due to its wide range of applications, such as mobile robotics, indoor sensing, autonomous driving, surface mapping, and human-machine interaction, previously driven by LIDARs, and 3D imaging systems [1], [2]. A ToF camera exploits the underlying principle of ToF to compute the radial distance between the ToF sensor and each scene point. An optical signal propagates through free-space at the speed of light,  $c \approx [3 \times 10^8]\text{m/s}$ , the distance  $d$  covered by an optical signal over the time  $\tau$  is  $d = c\tau$ . The optical signal is reflected by the scene and then returns to the ToF sensor. Provided that the distance covered by the light signal is  $2d$  at time  $\tau$ , and distance can be computed as  $d = \frac{c\tau}{2}$ .

ToF technology can be classified into *pulsed* ToF and *continuous-wave* (CW) ToF systems, considering the time or phase shift of the reflected signal with respect to the emitted signal, thereby yielding depth, respectively. In 1997, phased ToF cameras based on *charged coupled devices* (CCD) were pioneered by Prof. R. Schwarte, from the University of Siegen, Germany [3]. Since then, ToF imaging technology has been widely used in 3D imaging applications. The prominent core technology for CW-ToF cameras is known as *Photonic Mixer Device* (PMD). Despite of the many theoretical and engineering advances in ToF imaging in the last few years, the need for a dedicated illumination unit is one of the drawbacks of cutting-edge ToF cameras and results into high power consumption. However, this problem has received unfortunately little attention. Therefore, this has pushed the research community to look at alternative ways of illumination in indoor settings. In recent years, rapid advances in solid-state technology have profoundly transformed the lighting infrastructure from conventional lamps (e.g., incandescent and halogen) to light-emitting diodes (LEDs). LEDs are increasingly popular for displays and light sources due to their long lifetime, small size, low cost, energy efficiency, and very low  $\mathcal{O}(\mu\text{sec})$  switching transient [4]. Recently, new pathways have been opened by introducing modulated light sources, such as LEDs, which exhibit high modulation bandwidth. This motivated the migration from radio to optical spectrum to enable high-speed optical wireless communication. This has given a birth to an emerging communication technology known as Visible Light Communication (VLC). We have exploited the OpenVLC1.3 module as an illumination and communication source [5] that supports [1]MHz bandwidth. Existing VLC infrastructure (see Fig. 1b) illuminates the scene [6], and an asynchronous ToF camera captures the scene to retrieve depth. Our previous work [7] exploited a standard method for CW-ToF depth estimation, such as the four-phases algorithm, which results in an unknown depth offset. This unknown depth offset is due to the absence of synchronization between the source and the ToF camera. Furthermore, this passive modality still needs to be ameliorated to achieve accurate depth.

The bistatic configuration addresses the synchronization problem by providing two parallel channels, one of which establishes a direct link between the VLC source and a reference photodiode to obtain an external reference signal for the PMD camera. The second one is the sensing channel that captures scene reflections. The measurements profiles are obtained by performing a cross-correlation between the reference and the sensed signals. Besides,

the reference photodiode signals are not digital. So, we developed an appropriate signal conditioning to transform the analog signals into the digital signals that operate the PMD pixels. A custom PMD camera module with built-in external reference signal capability allows us to implement the bistatic operation in the passive ToF concept. This passive operation mode collides with the classical operation mode of ToF cameras based on PMD. The bistatic setup demonstration and a schematic of the proposed VLC-enabled passive 3D ToF system are shown in Fig. 1a and Fig. 2 respectively. Consequently, the sensing pipeline has to be revised according to the bistatic configuration [8]. Simulations are carried out in PB-ToF for varying measurement signal-to-noise ratio (SNR). The improvement of depth accuracy via passive modality is still a new area of research and will be explored further.

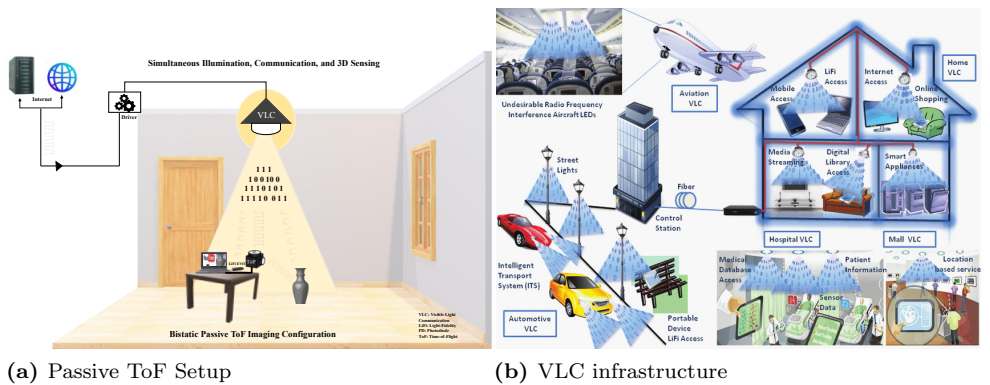

**Figure 1.** Bistatic VLC-enabled passive ToF Imaging configuration and readily available VLC infrastructure opportunities adopted from [9].

## 2 Opportunities and Limitations

The bistatic configuration translates drawbacks into opportunities. The background light is transformed into a useful optical signal for ToF sensing, while it was previously a challenge for ToF cameras. This also eliminates the need for an infrared filter and allows ToF cameras to become receiver-based systems, due to the proposed passive operation mode. The sensing accuracy depends on the light intensity, which may be low owing to indirect scattering of light, and the bandwidth of VLC sources, which may be less than that of a dedicated ToF illumination unit. Additionally, the need for adaptive thresholding may further reduced accuracy due to the existence of jitter.

## 3 Discussion and Conclusion

A novel passive ToF imager concept without an illumination unit for indoor sensing has been presented in this work. We leveraged commercially available components to develop the 'proof-of-concept' illustrated in Fig. 2. Based on our simulation results, we believe the PB-based ToF is superior to the CW-ToF approach for passive ToF. The root-mean-square error (RMSE) was evaluated in a preliminary noise analysis. An evaluation of the related

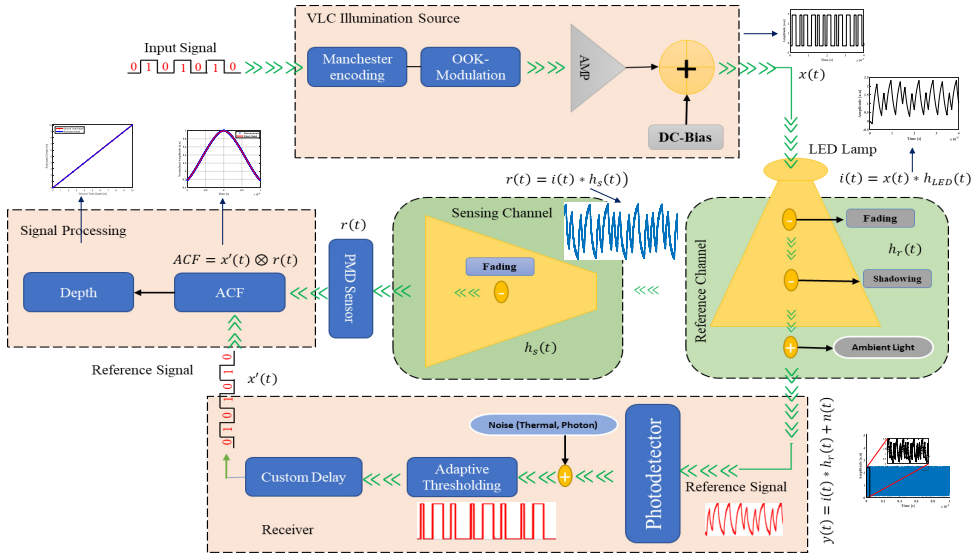

**Figure 2.** VLC-enabled Bistatic Passive ToF framework [8]. The illumination signal is represented by  $i(t)$ , the received photodiode signal is denoted by  $y(t)$ , and the autocorrelation function (ACF) is performed between thresholded signal  $x'(t)$  and the reflected signal  $r(t)$ .

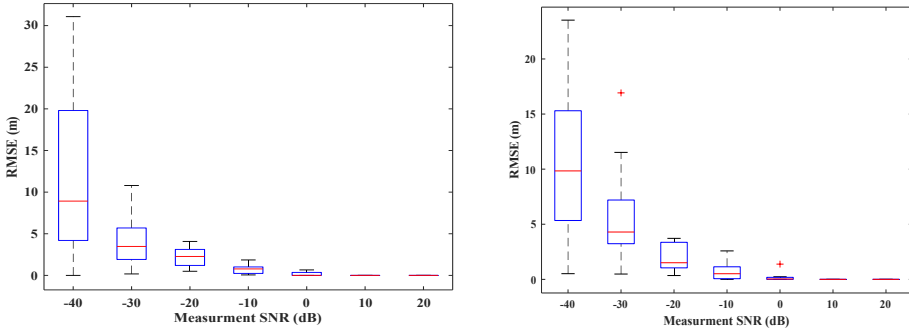

(a) RMSE vs. SNR for [10]m range                      (b) RMSE vs. SNR for [50]m range

**Figure 3.** Simulation results showing depth reconstruction error in RMSE vs. SNR for different target locations.

depth-RMSE for different ranges ([10]m and [50]m) are shown in Fig. 3. It can be seen that the RMSE decreases by increasing the measurement SNR, as expected until negligible values are attained. Furthermore, we demonstrated the possibility of simultaneously performing illumination, communication, and 3D ToF sensing. VLC is an integral part of the lighting infrastructure, allowing us to use ubiquitous modulated light signals to provide a novel kind of passive ToF sensing in indoor spaces. Simulations validate the proposed concept, and good fitting models of the cross-correlation function were found both for [10]m and [50]m (range). The overarching idea of this work is to dovetail both worlds—that of

VLC communication and that of ToF imaging—in the best possible way. This will reduce the cost and power consumption of the proposed system. This allows the entry into new application fields, such as smart homes, office premises, industries, and vehicles, where the VLC infrastructure (Fig.1b) and ToF cameras are valuable assets. Future research will focus on the evaluation of the experimental implementation.

## Acknowledgment

This project has received funding from the European Union’s Horizon 2020 research and innovation programme under the Marie Skłodowska-Curie grant agreement No: 860370 (MENELAOS<sup>NT</sup>).

## References

- [1] M. Heredia Conde, “Compressive sensing for the photonic mixer device,” in *Compressive Sensing for the Photonic Mixer Device*, Springer Vieweg, Wiesbaden, 2017, pp. 207–352.
- [2] A. Bhandari and R. Raskar, “Signal processing for time-of-flight imaging sensors: An introduction to inverse problems in computational 3-d imaging,” *IEEE Signal Processing Magazine*, vol. 33, no. 5, pp. 45–58, 2016.
- [3] R. Schwarte, *Method and apparatus for determining the phase and/or amplitude information of an electromagnetic wave for photomixing*, US Patent 7,053,357, May 2006.
- [4] H. Elgala, R. Mesleh, and H. Haas, “Indoor broadcasting via white leds and ofdm,” *IEEE Transactions on consumer electronics*, vol. 55, no. 3, pp. 1127–1134, 2009.
- [5] A. Galisteo, D. Juara, and D. Giustiniano, “Research in visible light communication systems with openvc1.3,” in *2019 IEEE 5th World Forum on Internet of Things (WF-IoT)*, IEEE, 2019, pp. 539–544.
- [6] A. Tsiatmas, C. P. Baggen, F. M. Willems, J.-P. M. Linnartz, and J. W. Bergmans, “An illumination perspective on visible light communications,” *IEEE Communications Magazine*, vol. 52, no. 7, pp. 64–71, 2014.
- [7] F. Ahmed, M. Heredia Conde, and O. Loffeld, “Pseudo-passive indoor tof sensing exploiting visible light communication sources,” in *2021 IEEE Sensors*, IEEE, 2021, pp. 1–4.
- [8] F. Ahmed, M. Heredia Conde, P. López Martínez, T. Kerstein, and B. Buxbaum, “Pseudo-passive time-of-flight imaging: Simultaneous illumination, communication, and 3D sensing,” *IEEE Sensors Journal*, pp. 1–1, 2022. DOI: 10.1109/JSEN.2022.3208085.
- [9] P. Deng, “Real-time software-defined adaptive mimo visible light communications,” *Visible Light Communications*, pp. 637–640, 2017.



# CS-based ToF Imaging

Alvaro Lopez Paredes, Miguel Heredia Conde, Otmar Loffeld

Center for Sensor Systems (ZESS), University of Siegen. Paul-Bonatz-Straße 9-11, 57076  
Siegen, Germany

Corresponding author: [alvaro.lparedes@uni-siegen.de](mailto:alvaro.lparedes@uni-siegen.de)

**Abstract.** *In this work, we explore several relevant concepts in Compressive Sensing (CS) theory. Firstly, we present two sensing schemes for the recovery of highly sparse signals named Sliced OMP and Zoned APEG. Then, we describe a number of construction methodologies for the sensing matrices which significantly reduce their coherence and density. The different procedures are validated through numerical simulations, and aim to ensure the successful reconstruction of the 3D scene under study with high probability.*

**Keywords.** Adaptive sensing, compressed sensing, 3D imaging, sparse recovery, Time-of-Flight.

# 1 CS-based ToF Imaging

## 1.1 Time-of-Flight Sensing Scheme and Signal Recovery Approaches

This study aims to investigate the 3D reconstruction of a scene from the measurements obtained by a pulse-based ToF camera. This yields the problem of recovering a very sparse echo signal for each ToF pixel. We exploit CS and sparsity-awareness techniques to perform this operation from few measurements and to achieve high depth resolution.

The first approach, whose structure is shown in Figure 1, is called Sliced Orthogonal Matching Pursuit (OMP) [1]. It is a non-adaptive procedure, since the construction of the sensing matrices does not require any previous knowledge of the signal to be recovered. It consists of the slicing of the spatial domain in a number of partitions in order to reduce the inter-column coherence ( $\mu$ ), i.e., to increase the dissimilarity between the columns of the sensing matrix. The signal is preliminarily localized between the partitions and, then, a greedy algorithm, such as OMP [2], is applied over the refined domain to retrieve the signal.

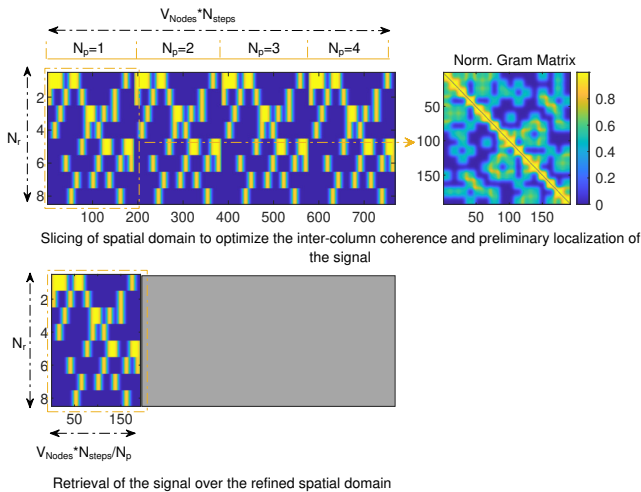

**Figure 1.** Sliced OMP

Zoned Adaptive Progressive Edge Growth (APEG) [6] extends the applicability of APEG [7] and paves the way to implement such a scheme in multi-aperture arrays [8]. The structure of Zoned APEG is presented in Figure 2. Zoned APEG builds the sensing matrix per rows by allocating a number of non-zero elements which accounts for the information on the signal support from the previous measurements, while it minimizes the coherence of the resulting matrix. When the process is complete, we can use the measurement vector and the sensing matrix generated to recover the signal. In our study, we use OMP for this purpose.



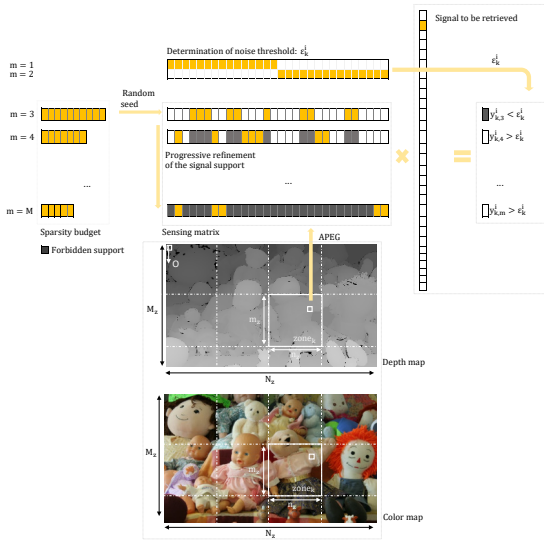

**Figure 2.** Zoned APEG over Middlebury dataset Dolls [3]–[5]

## 1.2 Sensing Matrices for Sliced OMP

Since the performance of Sliced OMP significantly depends on the selection of the type of sensing matrix, we perform an evaluation of different construction methodologies. Figure 3 summarizes the sensing matrices built via the different construction methodologies considered in [6], [9]–[11] and the corresponding normalized Gram matrices. The proposed techniques aim at minimizing their coherence and density. A low inter-column coherence helps ensuring unique reconstruction of sparse signals, whereas a low density reduces the memory footprint. The first four rows of Figure 3 present, from top to bottom, the sensing matrices from random binary (0,1)-codes, random binary (-1,1)-codes, (0,1)-Scrambled Hadamard Ensembles (SHEs) and (-1,1)-SHEs. The last four rows illustrate the sensing matrices generated using Low-Density Parity-Check (LDPC) codes generated via Progressive Edge Growth (PEG) [10], [11] and combinatorial approaches [6]. In addition, we present two extensions of these algorithms accounting for the non-instantaneous transitions from one element to another of the code which may lead to the coincidence of rising and falling edges and a subsequent degradation of the coherence. An evaluation of the performance of Sliced OMP using them as sensing matrices may be found in [1], [6].

Figure 4 shows the behaviour of the coherence with respect to the resolution of the grid and provides an estimation of the upper super-resolution limit, i.e., the minimum grid size which guarantees  $\mu < 1$  [6].

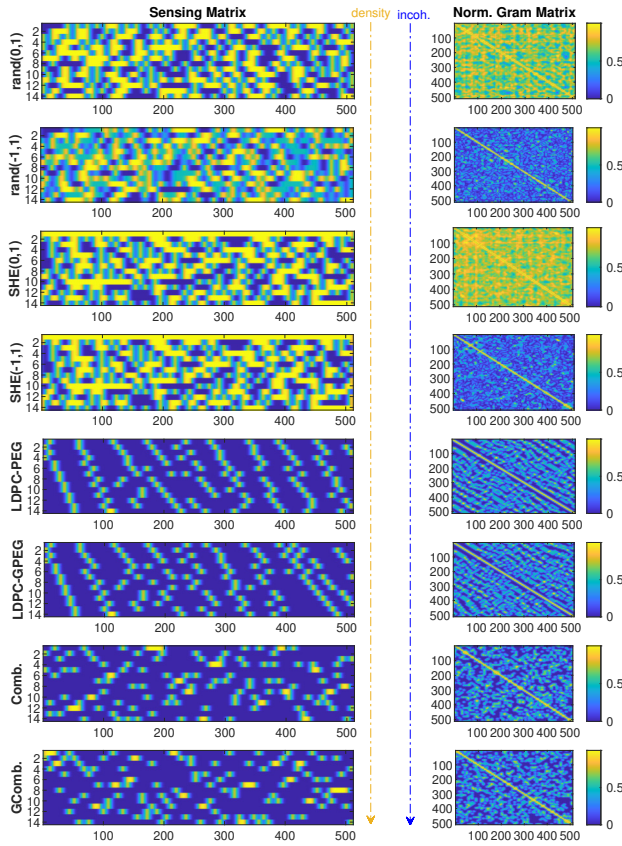

Figure 3. Sensing matrices for Sliced OMP

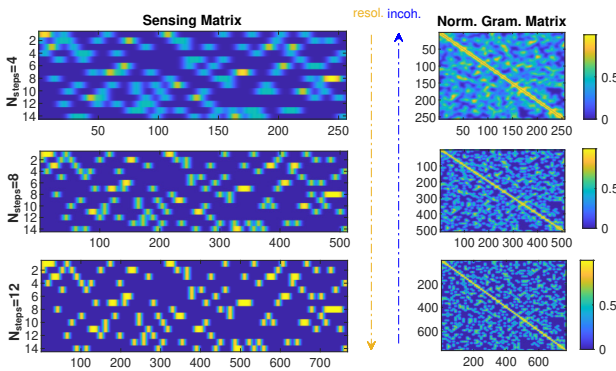

Figure 4. Upper limit for superresolution and discretization grid size

## Acknowledgments

This project has received funding from the European Union's Horizon 2020 research and innovation programme under the Marie Skłodowska-Curie grant agreement No 860370.

## References

- [1] A. Lopez Paredes, M. Heredia Conde, and O. Loffeld, "Effective very-wide-area 3D ToF sensing," in *2021 IEEE Sensors*, 2021, pp. 1–4. DOI: 10.1109/SENSORS47087.2021.9639585.
- [2] Y. C. Pati, R. Rezaifar, and P. S. Krishnaprasad, "Orthogonal matching pursuit: Recursive function approximation with applications to wavelet decomposition," in *Proceedings of 27th Asilomar Conference on Signals, Systems and Computers*, 1993, 40–44 vol.1. DOI: 10.1109/ACSSC.1993.342465.
- [3] D. Scharstein and C. Pal, "Learning conditional random fields for stereo," in *2007 IEEE Conference on Computer Vision and Pattern Recognition*, 2007, pp. 1–8. DOI: 10.1109/CVPR.2007.383191.
- [4] D. Scharstein and R. Szeliski, "High-accuracy stereo depth maps using structured light," in *2003 IEEE Computer Society Conference on Computer Vision and Pattern Recognition, 2003. Proceedings.*, vol. 1, 2003, pp. I–I. DOI: 10.1109/CVPR.2003.1211354.
- [5] H. Hirschmuller and D. Scharstein, "Evaluation of cost functions for stereo matching," in *2007 IEEE Conference on Computer Vision and Pattern Recognition*, 2007, pp. 1–8. DOI: 10.1109/CVPR.2007.383248.
- [6] A. Lopez Paredes, M. Heredia Conde, and O. Loffeld, "Sparsity-aware 3D ToF sensing," 2022. DOI: 10.36227/techrxiv.19161749.v1. [Online]. Available: [https://www.techrxiv.org/articles/preprint/Sparsity-aware%5C\\_3D%5C\\_ToF%5C\\_Sensing/19161749](https://www.techrxiv.org/articles/preprint/Sparsity-aware%5C_3D%5C_ToF%5C_Sensing/19161749).
- [7] M. Heredia Conde, K. Hartmann, and O. Loffeld, "Simple adaptive progressive edge-growth construction of LDPC codes for close(r)-to-optimal sensing in pulsed ToF," in *2016 4th International Workshop on Compressed Sensing Theory and its Applications to Radar, Sonar and Remote Sensing (CoSeRa)*, 2016, pp. 80–84. DOI: 10.1109/CoSeRa.2016.7745704.
- [8] M. Heredia Conde, K. Kagawa, T. Kokado, S. Kawahito, and O. Loffeld, "Single-shot real-time multiple-path time-of-flight depth imaging for multi-aperture and macro-pixel sensors," in *ICASSP 2020 - 2020 IEEE International Conference on Acoustics, Speech and Signal Processing (ICASSP)*, 2020, pp. 1469–1473. DOI: 10.1109/ICASSP40776.2020.9054565.

- [9] L. Gan, T. T. Do, and T. D. Tran, "Fast compressive imaging using scrambled block hadamard ensemble," in *2008 16th European Signal Processing Conference*, 2008, pp. 1–5.
- [10] X.-Y. Hu, E. Eleftheriou, and D.-M. Arnold, "Progressive edge-growth tanner graphs," in *GLOBECOM'01. IEEE Global Telecommunications Conference (Cat. No.01CH37270)*, vol. 2, 2001, 995–1001 vol.2. DOI: 10.1109/GLOCOM.2001.965567.
- [11] G. Srirutchataboon, A. Bajpai, L. Wuttisittikulij, and P. Kovintavewat, "Peg-like algorithm for LDPC codes," in *2014 International Electrical Engineering Congress (iEECON)*, 2014, pp. 1–4. DOI: 10.1109/iEECON.2014.6925956.

# Dose per Pulse Monitoring of MeV Photon Beams

Sara Pettinato<sup>1,2</sup>, Stefano Salvatori<sup>1,2</sup>

<sup>1</sup> Faculty of Engineering, Università degli Studi “Niccolò Cusano”, 00166 Rome, Italy

<sup>2</sup> Istituto di Struttura della Materia, Consiglio Nazionale delle Ricerche (ISM-CNR)  
00010, Montelibretti Rome, Italy  
{sara.pettinato, stefano.salvatori}@unicusano.it

**Abstract.** *Modern dynamic radiotherapies in cancer treatment are oriented to release high dose values in the shortest irradiation time. For these techniques, fast detectors and dedicated conditioning electronics will play a fundamental role for beam diagnostics to verify the necessary quality assurance requirements of treatments. This work describes a measurement system based on a single-crystal synthetic diamond able to monitor the dose released by each X-ray pulse generated by a medical LINAC. A gated-integration method, performed by a specifically designed electronics, has been used to measure the charge photogenerated in diamond by each impinging X-pulse. Exploiting the synchronization signal available in a LINAC apparatus, our system allows performing pulse-beam diagnostics with an acquisition time limited to the period around each pulse. Therefore, the proposed solution represents an effective tool for real-time dosimetry in modern radiotherapy applications and assures a better accuracy in comparison to conventional electrometer-based measurement systems that require longer acquisition periods.*

**Keywords.** Radiation therapy, precision integrator, medical linear accelerator, dose-measurements, diamond dosimeter, X-ray pulse.

## 1 Introduction

Radiation Therapy (RT) is a clinical method useful in the treatment of cancer. Using strongly ionizing radiation, RT can damage the DNA of the target, thus blocking the proliferation of cancer cells. Currently, dynamic precision RT techniques [1-2] are widely used. The aim is to concentrate the dose in the tumour volume, while protecting the surrounding healthy tissue, by delivering high dose gradients in a very short time. Accurate and precise dosimetry is becoming increasingly necessary to detect beam anomalies and to ensure delivery of the prescribed dose to the patient. This implies the need to use fast dosimeters having a very small active volume (less than 1 mm<sup>3</sup>). Because of its physical properties, diamond (natural and synthetic) allows to realize dosimeters that meet the requirements of modern dosimetry [3]. On the other hand, in addition to dosimeters that allow accurate dose measurements even for very narrow radiation beams, special measurement techniques are required. Indeed, the electronic system must acquire the dosimeter signal (charge or current) with very high time resolution, taking into account the pulsed nature of X-rays generated by medical LINACs used in RT. Each pulse has a duration of a few microseconds with a pulse-repetition-rate (PRR) in the range 60-1000 Hz. Especially for dynamic treatments, the accurate measurement of the dose delivered by each pulse of photons becomes fundamental. The typical measurement method used in clinical dosimetry is based on electrometers able to measure either currents or charges with an integration time in the 0.01 – 1 s range, i.e. integrating a large number of impinging pulses. Hence, the measurement techniques, as well as the applied instruments, are completely inadequate for the single-pulse diagnostics that modern RT requires. Accuracy is greatly enhanced employing a synchronized technique for signal acquisition, thus eliminating any contribution of noise during the relatively long time periods between two consecutive pulses. The literature is still poor of works regarding single-pulse dose measurements. Proposed solutions (e.g. in [4]) display a high response time, then becoming ineffective in the case of PRR of the order of kHz adopted in modern dynamic RT. Conversely, the solution described in this paper is able to monitor each pulse up to a PRR greater than 2 kHz. The specifically designed synchronous gated-integrator (GI) allows signal conditioning in a time interval around each pulse. This assures excellent performance of the proposed detection system in terms of signal-to-noise ratio (SNR), sensitivity and input dynamics.

## 2 Circuit Description and results

LINACs for RT are machines capable of producing beams of electrons and photons that, properly collimated, impinge on the target volume. In a LINAC, electron packets are accelerated until they acquire the desired energy to collide on a heavy metal target producing high-energy-pulsed X-rays. X-ray pulses have a duration of few microseconds and the dose-rate (DR) to be administered is regulated by the PRR.

In our experiments, a Clinac iX (Varian Inc.), installed at the Radiotherapy Department of “San Giovanni-Addolorata” Hospital in Rome (Italy), was used. Figure 1 shows the signals

measured at the apparatus console. The sync pulse is generated by the LINAC to synchronize its internal electronics, whereas the target pulse is proportional to the current generated by the electrons impinging on the metal target. As shown in Fig. 1, the target pulses, and then the X-ray pulses, have a duration of 4  $\mu\text{s}$ . The nominal dose-per-pulse values are 277.78  $\mu\text{Gy}$  and 555.56  $\mu\text{Gy}$  for 6 MV and 18 MV photons, respectively [5-6].

The realized GI electronics exploits the sync signal available at the LINAC console to establish the integration of signals in a period around each pulse [7]. A microcontroller unit synchronizes the signal integration, employees the analog-to-digital conversion and sends data to a computer. All the mentioned operation are performed within less than 500  $\mu\text{s}$ , thus allowing the real-time acquisition of pulses for PRRs greater than 2 kHz. A specifically designed Labview® program was developed for remote control of the prototype and data recording. Figure 2 illustrates the set-up adopted during the measurements.

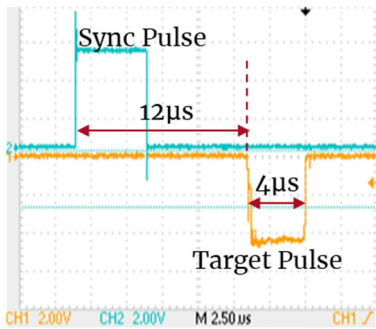
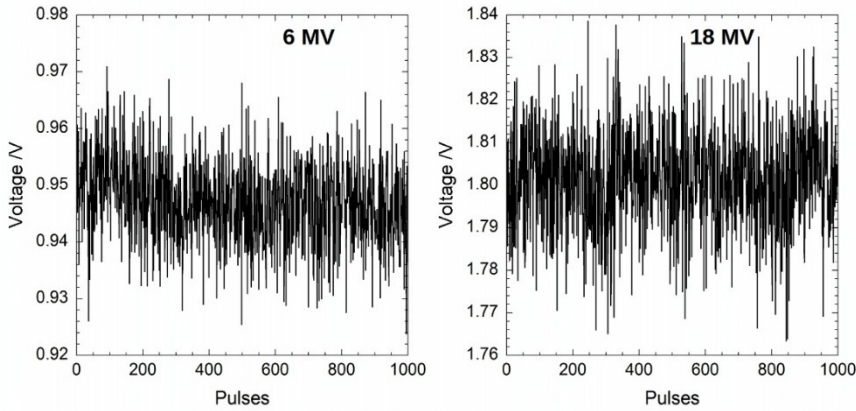

**Figure 1.** Sync and target pulses generated by the Clinac iX as acquired by the oscilloscope.



**Figure 2.** Set-up during the measurements with the Clinac iX. On the right, the realized GI prototype.

The prototype has been tested over both the full dose range and DRs typically used for clinical treatments, at the two available electron acceleration voltages of 6 MV and 18 MV. The diamond dosimeter was placed into a plexiglass phantom at the LINAC isocentre and biased at 10 V. Figure 3 shows the voltage signals at the GI output acquired for 1000 pulses when 6 MV and 18 MV X-rays impinged on the detector. The DR was regulated to 6 Gy/min for both the two energies.



**Figure 3.** Voltage signal acquired on 1000 pulses for 6 MV and 18 MV photons (DR=6 Gy/min).

Importantly, the amplitude variation of about the  $\pm 2\%$  is not related to noise, but to a change of the impinging pulse intensity. Indeed, it is worth to note that the cumulative sum of the charge-per-pulse is linearly dependent on time, as reported in Fig. 4. This perfectly agrees to what expected: fixed the DR, the dose administered by the medical LINAC must be only dependent on the treatment time. Cumulative charge values of Fig. 4 have been calculated considering an integration capacitance of 88.5 pF as measured by the in-lab characterization of the prototype [6].

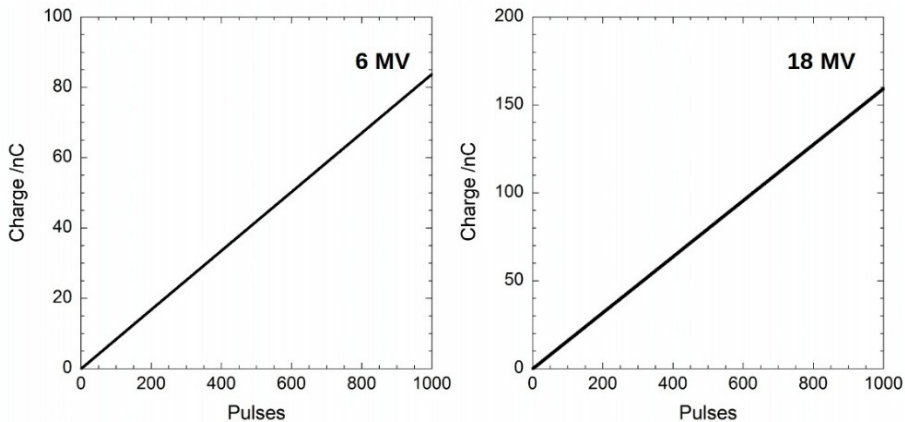
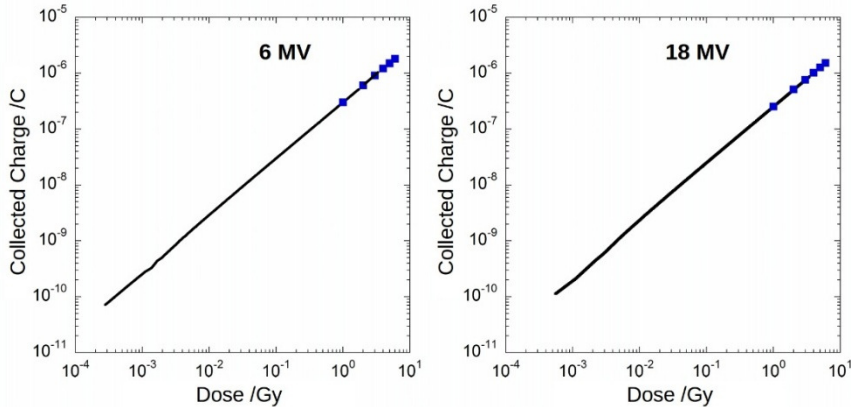

**Figure 4.** Cumulative sum of the charge-per-pulse acquired on 1000 pulses for 6 MV and 18 MV photons (DR = 6 Gy/min).

Finally, also the detector sensitivity to LINAC X-ray pulses has been evaluated. Figure 5 shows the data acquired by the proposed GI prototype (continuous lines). In the 1-6 Gy range, we also performed the measurements of the collected charge by means of a Keithley 6517A electrometer. Results reported in the figure highlight an excellent linearity of the detector response. It is important to observe that data acquired at the lowest dose values ( $< 10^{-2}$  Gy) refer to a few number of impinging pulses and thus affected by the above



mentioned amplitude change. The sensitivity of the diamond dosimeter was calculated by the slope of plots reported in Fig. 5:  $(300.64 \pm 0.08) \text{ nC} \cdot \text{Gy}^{-1}$  and  $(286.56 \pm 0.04) \text{ nC} \cdot \text{Gy}^{-1}$  for X-ray photons of 6 MV and 18 MV, respectively. In addition, best fit of data reported in Fig. 4 according a linear regression gives  $159.18 \text{ pC/pulse}$  (6 MV photons) and  $83.711 \text{ pC/pulse}$  (18 MV photons). Therefore, known the detector sensitivities (Fig. 5) dose-per-pulse values for 6 MV and 18 MV photons result equal to  $278 \text{ } \mu\text{G/pulse}$  and  $556 \text{ } \mu\text{Gy/pulse}$ , respectively, in excellent agreement to what expected for the Clinac iX apparatus.



**Figure 5.** Collected charge as a function of dose for X-rays at 6 MV and 18 MV. Continuous lines refer to data acquired by our prototype, whereas blue dots are values measured by a Keithley 6517A.

### 3 Conclusions

A detection system based on a single crystal diamond dosimeter coupled to a dedicated front-end/readout electronics was developed and fully characterized on the field under X-rays produced by a medical LINAC used for RT in cancer treatments. Experimental results demonstrate that the system allows for accurate real-time pulse-by-pulse dose measurements, thus meeting the demands of quality assurance in dosimetry, particularly stringent in modern dynamic RT. The main advantage of the proposed electronics, resulting from the simplicity of the circuit, is the extremely low number and low cost of the used components. In addition to compactness and cost effectiveness, this guarantees both the reliability and the maintainability of the system, as well as an excellent measurement accuracy comparable to that of complex electrometer-based solutions.

## References

- [1] Y. Ge and Q. J. Wu, “Knowledge-based planning for intensity-modulated radiation therapy: A review of data-driven approaches,” *Med. Phys.*, vol. 46, no. 6, pp. 2760–2775, 2019, doi: 10.1002/mp.13526
- [2] G. Macchia et al. “Volumetric modulated arc therapy for treatment of solid tumors: Current insights,” *Onco. Targets. Ther.*, vol. 10, pp. 3755–3772, 2017, doi: 10.2147/OTT.S113119.
- [3] C. Talamonti et al., “Diamond Detectors for Radiotherapy X-Ray Small Beam Dosimetry,” *Frontiers in Physics*, vol. 9, 2021, doi: 10.3389/fphy.2021.632299.
- [4] J.J. Velthuis et al., “Toward Pulse by Pulse Dosimetry Using an SC CVD Diamond Detector,” *IEEE Trans. Radiat. Plasma Med. Sci.*, vol. 1, no. 6, pp. 527–533, 2017; doi: 10.1109/TRPMS.2017.2750799.
- [5] S. Pettinato, M. Girolami, R. Olivieri, A. Stravato, C. Caruso, C., S.Salvatori, “Diamond-based Detection Systems for Accurate Pulsed X-rays Diagnostics in Radiotherapy,”. arXiv preprint arXiv 2109.14547, 2021, doi: 10.48550/arXiv.2109.14547.
- [6] S. Pettinato et. al. “Time-resolved dosimetry of pulsed photon beams for radiotherapy based on diamond detector,” *IEEE Sens, Jour.* 22(12), pp. 12348-12356, doi: 10.1109/JSEN.2022.3173892.
- [7] S. Pettinato, A. Orsini, M. Girolami, D. M. Trucchi, M. C. Rossi, and S. Salvatori, “A high-precision gated integrator for repetitive pulsed signals acquisition,” *Electron.*, vol. 8, no. 11, 2019, doi: 10.3390/electronics8111231.

# Heat Capacity and Internal Thermal Resistance Measurements in Lithium-ion

Paola Serao<sup>1</sup>, Gino Bella<sup>1</sup>

<sup>1</sup> Università degli Studi Niccolò Cusano,  
Via don Carlo Gnocchi 3, 00166, Rome, Italy  
{paola.serao, gino.bella}@unicusano.it

**Abstract.** *The heat capacity and the internal thermal resistance of lithium-ion batteries are two important parameters for the thermal modelling of cells. These parameters are not generally available from manufactures or stated on cell datasheets. Particularly, measurements of the specific heat capacity of the cell would require disassembly of the cell and the use of an expensive calorimeter. This work describes a simple method for the measurement of both the heat capacity and the internal resistance of a cell. The method only requires an electrical characterization of the cell from which a good estimate of the thermal parameters is obtained. The method has been verified on a cylindrical lithium-ion cell. Experimental data are in excellent agreement to those obtained by conventional method of specific heat capacity measurements, thus validating the proposed setup for the thermal modelling of lithium-ion cells.*

**Keywords.** Lithium-ion battery, heat capacity, internal thermal resistance, overvoltage, thermal Modelling

## 1 Introduction

Recently, energy storage has attracted a significant amount of research attention, mainly with the final target in transportations. Among the several types of batteries, lithium-ion cells have emerged for their high capacity, high efficiency, long life and low self-discharge rate. Accurate thermal model of battery cells is fundamental for adequate design of battery-pack especially for designing devices guaranteeing the safety during operation.

The thermal model of lithium-ion cells is often referred to the single point heat generation [1]. The heat is generated inside the cell in a point having a known mass and a specific heat capacity. Heat is then transferred from the inside to the surface of the cell and finally to the external environment. Different methods are adopted for the measurement of the specific heat capacity of a cell [2]. Depending on the adopted thermal model, heat capacity of the entire cell may be either: (i) a function of the values found for the different materials of the cell; or (ii) a single value expressing the heat capacity of the entire cell. In the former, to find the value for each component, the simplest approach involves disassembly of the cell, i.e. its destruction. In this case, the weighted sum of the heat capacities of each component gives the heat capacity of the cell. For the latter, the cell is characterized as is and a calorimeter is employed to measure its heat-capacity [3].

In this paper, a non-destructive method to determine both the heat capacity and the internal thermal resistance of lithium-ion cells is illustrated. The method implies the estimation of the two thermal parameters by cell's overvoltage measurements. Although referred to a specific cell, the two mentioned terms remain the same also in a more complex scenario, i.e. battery packs.

The report is structured as follows. Section 2 illustrates the theoretical background of the proposed approach. The experimental setup and the experimental results are described in Section 3 and Section 4, respectively. The conclusions are summarized in Section 5.

## 2 Theory

In an electrochemical cell, the available electrical energy can be calculated from the change in Gibbs free energy of the electrochemical couple [4]:

$$\Delta G = -n \cdot F \cdot OCV \quad (1)$$

where  $n$  is the number of electrons exchanged in the reaction,  $F$  the Faraday constant and  $OCV$  the open circuit voltage. When the cell is at equilibrium, not all the available energy can be converted into useful electrical energy: when a current flows in the cell, its voltage ( $V_{cell}$ ) deviates from the value found at equilibrium. This effect reduces the amount of energy that the cell can convert. Depending on the direction of the current, this voltage deviation is termed as overvoltage or undervoltage [5]. In this work, simply referring on overvoltage, voltage deviation is calculated as:

$$\eta = OCV - V_{cell} \quad (2)$$

which is directly related to the energy dissipated as heat during transport and transfer phenomena [2].

Overtoltage contributions can be due to ohmic and non-ohmic effects. In ohmic conduction, only purely resistive effects are taken into account [6]. Non-ohmic contributions relate to polarizations losses that include: (i) concentration of a polarization, caused by spatial variations in the reactant concentration occurring in the bulk of the electrolyte or at the electrodes [7]; (ii) activation of a polarization deriving from the energy required to overcome the activation barrier of chemical reactions [6, 8].

Overtoltage value can be measured on a cell if discharged under a constant current [9]. In this case, the heat dissipated during the discharge process is given by:

$$P = \eta \cdot I \tag{3}$$

Integration of Eq. (3) over time represents the total energy the cells dissipates as heat. The heat capacity is then calculated by:

$$C = \frac{Pdt}{\Delta T} \tag{4}$$

where P is the heating power, T the battery temperature, and t the time.

The internal thermal resistance of a cell is simply given by:

$$R_i = \frac{\eta}{i} \tag{5}$$

i.e. a linear relationship between the current and the overvoltage amplitude.

The method used in this work and described in the following involved several charging-discharging cycles of the cell. In each cycle, the cell was maintained into its nominal operating conditions declared by the manufacturer.

### 3 Experimental setup

A lithium-ion cell (mod. 18650, Samsung) was characterized during this work. In order to simulate the optimal operating conditions, a constant-current source circuit was realized (Fig. 1). A fixed source/sink current of 2.5 A was adjusted for the experiments. However, a 10 mΩ shunt was also inserted in series to the cell for the continuous monitoring of the current value.

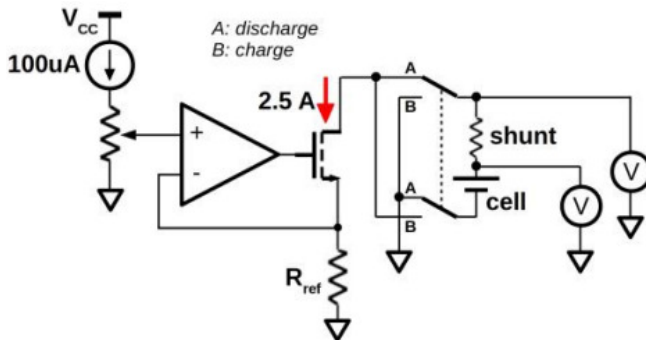

**Figure 1.** Simplified schematic of the circuit used during charge/discharge cycles

Three platinum resistance sensors (PT100 RS 158-985 PTFE) have been used for the temperature monitoring of the cell surface. The sensors were glued with silver paste at the centre and close the two poles of the cell. The voltage and the sink current of the cell, as well as the three temperatures, have been measured by means of a multi-channel acquisition system from National Instruments. A specifically designed Labview® program was developed for acquisition, processing and recording of data during the charge/discharge cycles. Figure 2 shows a picture of the adopted setup.

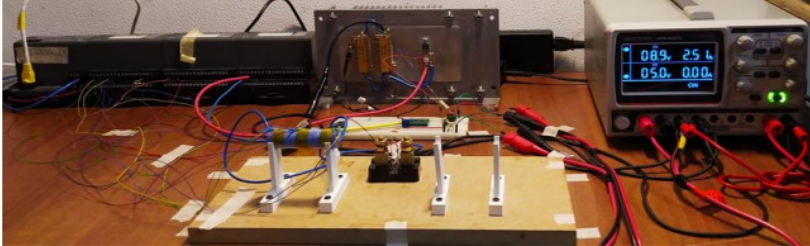

**Figure 2.** Experimental setup

## 4 Results and discussion

Up to 100 charge/discharge cycles have been carried out on the cell. Figure 3 shows four cycles as examples of the typical overvoltage behaviour. During a discharge cycle,  $\eta$  is approximately constant around 0.13 V.

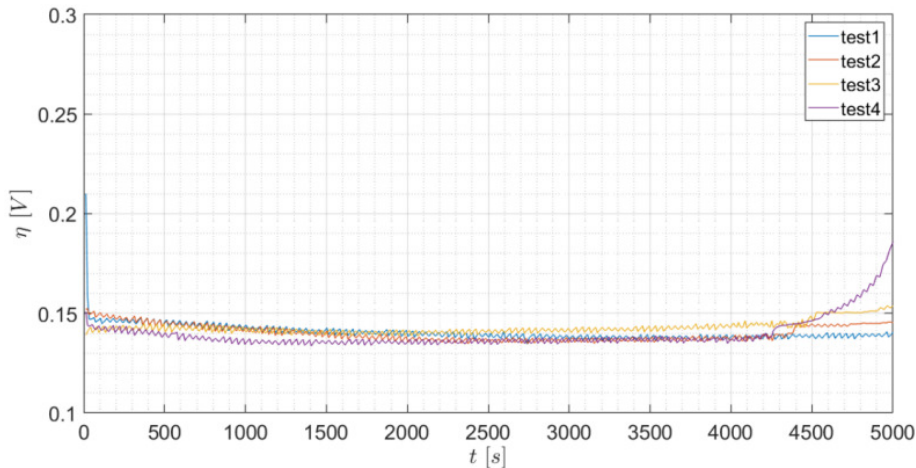

**Figure 3.** Overvoltage trend

The dissipated power can be calculated according to Eq. (3). As already mentioned, integrating the dissipated power over time gives the total energy dissipated as heat. By the energy dissipated as heat and the temperature changes over time, the heat capacity of the cell was calculated (see Eq. (4)). For the temperature, the values acquired by the sensor

located at the centre of the cell surface was used, being the highest found in all the acquisitions. Based on the data collected during the cycles, the heat capacity of the cell resulted of about  $280 \text{ J} \cdot \text{K}^{-1}$ . Moreover, from Eq. (5), and internal thermal resistance of about  $0.18 \Omega$  was also evaluated.

To validate the obtained results, a conventional method [2] was employed. A thermos-insulating container was filled with deionized water and a cell was then immersed into the water. After hermetical closure of the container, the temperature of the water was monitored over time by means of a PT100 sensor. If  $T_{end}$  is the temperature at system equilibrium, the heat capacity of the cell,  $C_{cell}$ , can be calculated as:

$$C_{cell} = \frac{c_{ref}m_{ref}(T_{end}-T_{ref})}{m_{cell}(T_{cell}-T_{end})} \quad (6)$$

where  $C_{ref}$  is the heat capacity of deionized water,  $T_{ref}$ ,  $T_{cell}$ ,  $m_{cell}$  and  $m_{ref}$  the start temperatures and masses of the water and the cell, respectively. To enhance the accuracy, the measurements were performed by immersing three cells into the bath. A specific heat capacity of  $286 \text{ J} \cdot \text{K}^{-1}$  was obtained, in excellent agreement with the value calculated by overvoltage measurements.

## 5 Conclusion

The thermal modelling of lithium-ion batteries is fundamental for battery-packs applications. Cell datasheets do not report any data useful to evaluate the thermal parameter of a cell. In this report, a measurement method for the specific heat capacity of lithium-ion cells has been described. Overvoltage measurement during several charge/discharge cycles allowed estimating both the heat capacity and the internal thermal resistance of a cell. These parameters are fundamental for the thermal modelling of single cell, but can be easily adapted to battery modules or packs.



## References

- [1] K. Onda et al., «Thermal behavior of small lithium-ion battery during rapid charge and discharge cycles,» *J. of Power Sources*, 158, 535–542, 2006.
- [2] Y. Tang, et al., «Review of specific heat capacity determination of lithium-ion battery,» *Energy Procedia*, 158, 4967-4973, 2019
- [3] N. S. Spinner et al., «Analytical, numerical and experimental determination of thermophysical properties of commercial 18650 LiCoO<sub>2</sub> lithium-ion battery,» *Electrochemical Society J.*, 162, A2789, 2015.

- [4] J. Newman and T. Karen, *Electrochemical systems*, John Wiley & Sons, 2012
- [5] D. Linden, *Handbook of batteries*, vol. 4, 1995, p. 265.
- [6] U. Kim et al. «Modelling the thermal behaviour of a lithium-ion battery during charge,» *J. of Power Sources*, 196, 5115-5121, 2011.
- [7] S. Chacko et al., «Thermal modelling of Li-ion polymer battery for electric vehicle drive cycles,» *J. of Power Sources*, 213, 296-303, 2012.
- [8] P. Myers et al., «Thermal energy storage using chloride salts and their eutectics,» *Applied Thermal Engineering*, 109, 889-900, 2016.
- [9] C. Forgez et al., «Thermal modeling of a cylindrical LiFePO<sub>4</sub>/graphite lithium-ion battery,» *J. of Power Sources*, 195, 2961-2968, 2010.



# Multi-sensor Characteristics and Application-based Processing

Zhouyan Qiu<sup>1,2</sup>, Pedro Arias-Sánchez<sup>1</sup>, Joaquín Martínez-Sánchez<sup>1</sup>

<sup>1</sup> Applied Geotechnologies Research Group, University of Vigo  
zhouyan.qiu@uvigo.es

<sup>2</sup> ICT & Innovation Department, Ingeniería Insitu

**Abstract.** *There are three challenges associated with any mobile mapping system: accuracy, robustness, and cost. Considering the above challenges, the student's task is primarily to analyze the possibility of new sensors being integrated into the mobile mapping system. In view of its advanced features, including a gyroscope, accelerometer, 4K RGB camera, and Depth camera, Microsoft Azure Kinect is considered to be a potential candidate. The Cam-Board pico Monstar from Pmdtec is another type of depth sensor that is highly powerful and versatile and has a measuring range of 6 meters. We are responsible for characterizing these sensors and determining their suitability for their intended application.*

**Keywords.** Sensor characterization, time-of-flight camera, depth camera, multi sensor, sensor integration

# 1 Introduction

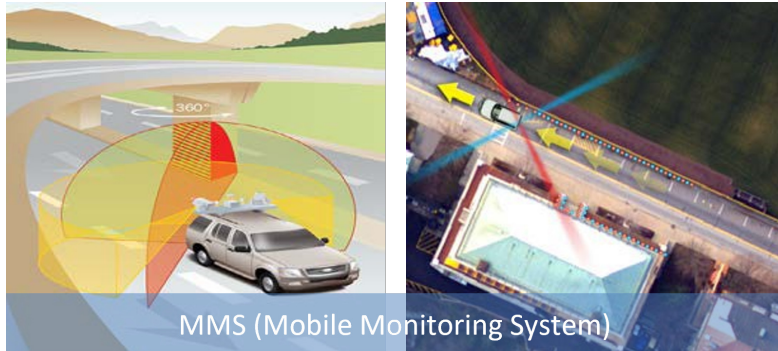

**Figure 1.** An example of Mobile mapping system

Figure 1 illustrates an example of Mobile mapping system. In general, the following sensors are integrated in a multi sensor system:

- 2D/3D Laser Scanner
- IMU/GNSS unit
- Imaging system
- Mounting platform

The three challenges that come with any mobile mapping system are accuracy, robustness, and cost. In a mobile mapping system, multiple Laser scanners and cameras are usually main exteroceptive sensors. Cameras can provide accuracy result and usually inexpensive, but they are very sensitive to light conditions. Laser scanners of high precision, such as 64-beam Laser scanners, are very expensive. A 2D Laser scanner or 16-beam Laser scanner, on the other hand, is not as expensive, but accuracy is not as high.

Considering the above challenges, it is proposed that new sensors be integrated into the mobile mapping system. In this study, two new sensors are expected to be added to the system.

## 1.1 Azure Kinect

Azure Kinect features advanced computer vision and speech models, advanced AI sensors, and a range of powerful SDKs [1], including these sensors: Gyroscope and accelerometer, RGB camera, Depth camera, IR emitters, and microphone array.

## 1.2 Pmdtec Monstar

The CamBoard pico monstar is one of the most powerful and versatile depth sensing system, offering a Field of View (FoV) of  $100^\circ \times 85^\circ$  degrees and pixel resolution of  $352 \times 287$  with a range of 6m, and is powered by USB[2].

## 2 Sensor characterization and appropriate application assessment

### 2.1 Using one Azure Kinect: RGB guided IR image reconstruction

RGB cameras have a high resolution, but they are greatly influenced by ambient light when they are used outside. Infrared cameras on the other hand have high noise levels and low resolution, but they are less affected by light conditions. If the advantages of RGB cameras and infrared cameras are combined, outdoor data performance will be greatly enhanced.

The focus of the research is on how to register RGB images and infrared images. It also focuses on the use of Deep Learning for improving infrared image resolution using the information from the corresponding RGB image (Figure 2). Various types of neural networks are used for testing, such as GAN and transformer, which are both well known. As a central concept, a generative adversarial network (GAN) is based on indirect training through a discriminator that is updated dynamically as well. The generative network generates candidates while the discriminative network evaluates them. This enables the model to learn in an unsupervised manner.

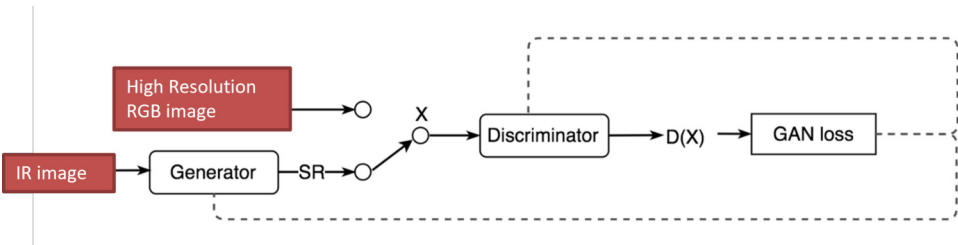

Figure 2. Workflow of RGB guided IR image reconstruction

### 2.2 Using Pmdtec and Azure Kinect: Sensor synchronization

In the area of multi-dimensional time-of-flight (ToF) depth sensing, Pmdtec is a leading technology provider. Section 1.2 introduced the basic parameters of Pmdtec Monstar ToF camera.

Considering that Monstar can only generate depth images, it is imperative to integrate other imaging sensors with Monstar. The Azure Kinect solution is a suitable option since it can acquire RGB images, depth images, and IMU data simultaneously. Azure Kinect and Monstar can be integrated to develop a simple-low cost outdoor multi-sensor system (Figure 3).



**Figure 3.** Integration of Monstar and Azure Kinect

### 3 Results and discussion

#### 3.1 RGB guided IR image reconstruction

As can be seen from Figure 4, the image generated by the GAN network is smoother than an infrared image, with less noise and a higher resolution when compared with an infrared picture. Additionally, it is less affected by lighting conditions than RGB images.



**Figure 4.** Left: the infrared image; Middle: the reconstructed grey image; Right: RGB image

#### 3.2 Using Pmdtec and Azure Kinect: Sensor synchronization

Figure 5 the interface of a ROS system which subscribe the topics from Azure Kinect and Pmdtec Monstar at the same time. The two sensors are synchronized by the global variable `TimeSynchronizer`. However, these results were not very encouraging. Further research should be undertaken to compress the data volume.

### 4 Conclusion

The objective of this study was to evaluate the possibility of integrating new sensors, e.g., Azure Kinect and Pmdtec Monstar, within mobile mapping systems. The insights gained from this study may be of assistance for Mobile Mapping applications based on devices mounted on non-dedicated vehicles. This study is limited by the requirement of large amounts of data transmissions and intensive calculations. Continued efforts are needed to compress the data.

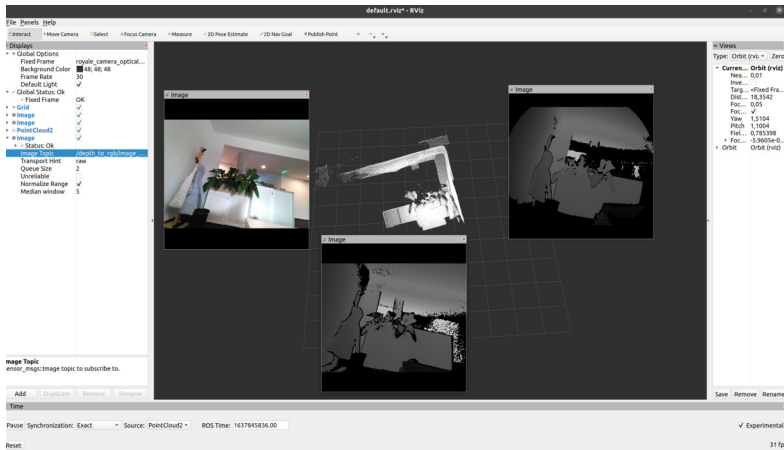

**Figure 5.** Integration of Azure Kinect and Pmdtec Monstar in a ROS system (In the middle: the generated point cloud)

## Acknowledgments

This project has received funding from the European Union’s Horizon 2020 research and innovation programme under the Marie Skłodowska-Curie grant agreement No 860370.

The work was carried out at CEOSpaceTech, Bucharest, Romania and Pmdtec, Siegen, Germany. Thank you to the staff there, and especially to Prof. Dr. Daniela Coltuc, Prof. Dr. Mihai Datcu, and Dr. Oliver Lottner who have provided valuable feedback.

## References

- [1] Microsoft. “Azure kinect dk – develop ai models.” (2022), [Online]. Available: <https://azure.microsoft.com/en-us/services/kinect-dk/>.
- [2] pmdtechnologies. “Monstar: Picofamily.” (2022), [Online]. Available: <https://pmdtec.com/picofamily/monstar/>.



# Semantic Information Discovery and Complex-Valued Deep Architectures for SAR Data Processing

Reza Mohammadi Asiyabi<sup>1</sup>, Mihai Datcu<sup>1,2</sup>, Andrei Anghel<sup>1</sup>, Holger Nies<sup>3</sup>

<sup>1</sup> Research Center for Spatial Information (CEOSpaceTech), University Politehnica of Bucharest, Bucharest, Romania  
{reza.mohammadi, andrei.anghel2407}@upb.ro

<sup>2</sup> Earth Observation Center (EOC), German Aerospace Center (DLR), Wessling, Germany  
mihai.datcu@dlr.de

<sup>3</sup> Center for Sensor Systems (ZESS), University of Siegen, 57074 Siegen, Germany  
holger.nies@uni-siegen.de

**Abstract.** *In the first year of my PhD project, as the fifteenth Early Stage Researcher (ESR) of the MENELAOS-NT project, I have focused on two objectives of my thesis. In the first objective, I have exploited semantic data mining techniques for latent information discovery from various Earth Observation images. In the second goal and as the continuity of the first aspect, I have studied complex-valued deep architectures for Synthetic Aperture Radar (SAR) data processing in order to utilize both the amplitude and phase information in SAR images.*

**Keywords.** Earth observation, data mining, semantic information, synthetic aperture radar (SAR), complex-valued neural network, classification

## 1 Introduction

My work in the last year was focused on two main topics (1) the semantic data mining for information discovery from Earth Observation (EO) images, and (2) complex-valued deep architectures for SAR data processing. In this regard, I have published three conference paper IGARSS 2021 [1], EUSAR 2022 [2] and IGARSS 2022 [3], and one peer-reviewed journal paper IEEE J-STARS [4].

The title of my research project is “Deep learning for SAR data in presence of adversarial samples” and the main objective is to develop deep learning solutions for spontaneous adversarial samples in SAR data classification. In order to achieve this goal, I started my research with generative models and datamining for latent semantic information discovery from EO images. Later, I started the development of complex-valued deep architectures for complex-valued SAR data processing and generating a complex-valued SAR annotated dataset. In the next step, I will focus on the elaboration of uncertainty-aware deep architectures and complex-valued generative models for SAR data classification.

## 2 Research Focus

My main focus on this research was on two main topics, (1) generative models and semantic data mining techniques for latent information discovery from EO images in various contexts, and (2) development of complex-valued deep architectures for SAR data processing in order to comprehensively harness the amplitude and the phase information of the complex-valued SAR images. A brief introduction on each of these topics is provided in this section.

### 2.1 Semantic Analysis

Regarding the semantic information discovery, the main objective and focus of my study was on the lack of semantic data mining researches for remote sensing applications in different contexts. I implemented data mining latent semantic information discovery methods, based on the Latent Dirichlet Allocation (LDA) and Bag of Visual Words (BOVW) models for various EO images and acquired satisfactory results for different application scenarios. The experimental results demonstrated the applicability of the semantic data mining techniques for information discovery in different remote sensing applications. In this respect, I presented the results of the semantic data mining in the IGARSS 2021 conference [1] and published the extended version of the research in the IGARSS 2021 special issue of the IEEE J-STARS journal [4]. Figure 1 represents an example application of the semantic data mining for EO images. In this example, three scenes of the Sentinel-1 SAR image are classified into 7 different semantic classes, using conventional classification approaches (e.g., Gabor features and Support Vector Machine (SVM) classifier). However, several misclassifications are evident in the classification results (Figure 1, left images). A semantic data mining method, based on the LAD and BOVW models is applied on the classified maps to remove the misclassified



patches and the patches with ambiguous semantic labels (Figure 1, right images). The removed patches are represented with black colour. The semantic data mining reduced the size of the dataset by about 10%, however the annotation quality is improved drastically and the number of the misclassified patches are reduced noticeably. More examples and further explanations are provided in the [1] and [4] articles.

## 2.2 Complex-valued Deep Architectures

Regarding the complex-valued SAR data processing, the main goal of the study is to exploit both the amplitude and phase information of SAR data in deep learning methods. Despite the remarkable developments and the state-of-the-art results of the real-valued deep networks for various SAR processing applications, these networks neglect the phase component of the complex-valued SAR data, which contains considerable valuable information, especially for constructed and urban areas classification. A few studies have proposed the conversion methods for real-valued mathematical operators into the complex domain, which are necessary for the development of complex-valued deep networks.

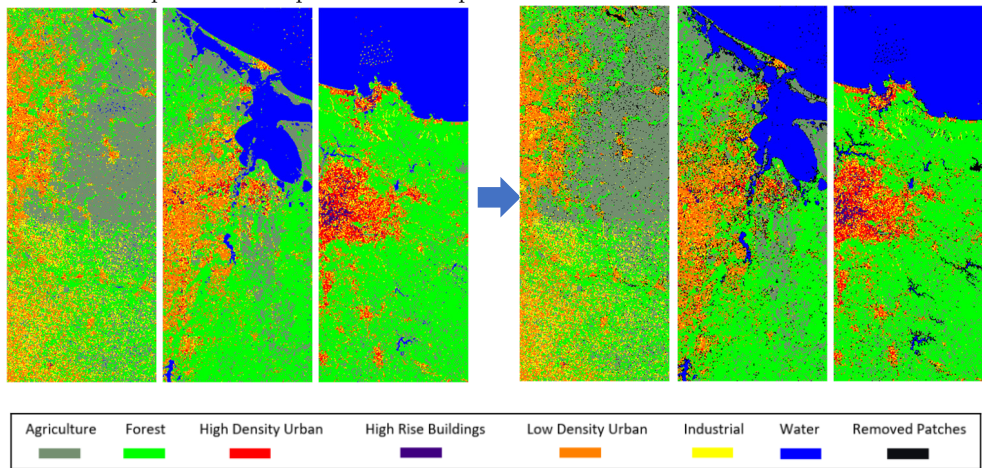

**Figure 1.** An example application of the semantic data mining for EO images.

As a part of my project, I developed a library of the necessary functions for complex-valued neural networks, based on the real-valued operators of the PyTorch library in the Python environment. I defined a Complex-Valued Convolutional AutoEncoder (CV-CAE), using the developed library, and obtained satisfactory reconstruction of the complex-valued SAR images from the azimuth subaperture decompositions for Sentinel-1 StripMap Single Look Complex (SM SLC) data. The evaluation measures illustrated that the developed CV-CAE preserves the coherency and the phase information of the complex-valued SAR images. Moreover, to examine the coherency preservation of the CV-CAE, the subaperture images from the reconstructed SAR images are calculated and compared with the subaperture images from the original SAR data. The very high correlation between the subaperture images demonstrated the coherency preservation of the CV-CAE. In this regard, I have published

two conference papers (EUSAR 2022 [2] and IGARSS 2022 [3]). My ongoing work in this field is aimed at the utilization of the complex-valued latent representation of the SAR images in the CV-CAE in order to develop a complex-valued classification of SAR data for urban areas. A complex-valued Convolutional Neural Network (CV-CNN) will be developed to classify the SAR patches, utilizing the latent representation of the CV-CAE network.

### 3 Conclusion

In conclusion, I have studied semantic data mining methods, including BOVW and LDA models, for latent information discovery for remote sensing applications in different contexts and demonstrated the necessity of semantic data mining for state-of-the-art EO systems. Moreover, I studied the complex-valued deep architectures for SAR data processing. Complex-valued networks will enable us to take advantage of the amplitude and phase components of the SAR data and extract more useful information from a limited number of annotated SAR images for urban areas classification.

### Acknowledgments

This project has received funding from the European Union's Horizon 2020 research and innovation programme under the Marie Skłodowska-Curie grant agreement No 860370.

### References

- [1] R. M. Asiyabi and M. Datcu, "Earth Observation Image Semantics: Latent Dirichlet Allocation Based Information Discovery," in *2021 IEEE International Geoscience and Remote Sensing Symposium IGARSS*, 2021, pp. 2620–2623.
- [2] R. M. Asiyabi and M. Datcu, A. Anghel, H. Nies, "Complex-Valued Autoencoders with Coherence Preservation for SAR," in *2022 European Conference of Synthetic Aperture Radar EUSAR*, 2022.
- [3] R. M. Asiyabi and M. Datcu, H. Nies, A. Anghel "Complex-Valued vs. Real-Valued Convolutional Neural Network for PolSAR Data Classification," in *2022 IEEE International Geoscience and Remote Sensing Symposium IGARSS*, 2022.
- [4] R. M. Asiyabi and M. Datcu, "Earth Observation Semantic Data Mining: Latent Dirichlet Allocation-based Approach," *IEEE Journal of Selected Topics in Applied Earth Observations and Remote Sensing*, 15, 2022, 2607-2620.

# Single-measurement Determination of Molar Fraction and Temperature of Binary Gas Mixtures from Combined Laser Induced Grating and Four-wave Mixing Signals

Jonas I. Hölzer<sup>1</sup>, Dimitrii N. Kozlov<sup>2</sup>, Thomas Seeger<sup>1</sup>

<sup>1</sup> Engineering Thermodynamics Siegen, University of Siegen, Paul-Bonatz-Str. 9-11,  
57076 Siegen  
{jonas.hoelzer, thomas.seeger}@uni-siegen.de

<sup>2</sup> A.M. Prokhorov General Physics Institute Russian Academy of Sciences, 119991,  
Moscow, Russia  
dnk@kapella.gpi.ru

**Abstract.** *The laser induced grating (LIG) technique is a powerful, versatile, non-intrusive measurement technique that employs the generation of a density grating by application of the strong electric fields of a laser. Studying the resulting energy release in the time domain gives access to a manifold of thermodynamic, fluiddynamic and material properties. Typically, the determination of different properties is mutually exclusive i.e., all other properties need to be known for the accurate determination of an unknown. We demonstrate concurrent determination of temperature and concentration in CO<sub>2</sub>-N<sub>2</sub> mixtures from the same measurement exploiting the occurrence of a four-wave mixing signal contribution to the LIG signal.*

**Keywords.** Laser induced grating spectroscopy, Gas phase diagnostics, time-domain measurements, four-wave mixing, multiparameter measurements

## 1 Introduction

Crossing of short laser pulses in a medium leads to interference of the incident electromagnetic fields and generates a grating of alternating strong and weak electric field. The fringe spacing of this laser induced grating (LIG) is governed by the laser wavelength and the angle of incidence. The strong electric field at regions of constructive interference leads to a polarization of the medium. This generates two counter propagating density i.e. sound waves, which result in a modulation of the refractive index. This is known as an electrostrictive grating (LIEG). Therefore, observation of the intensity of a refracted probe beam over time gives access to the energy release and the sound velocity and thereby a multitude of thermodynamic, fluiddynamic and molecular properties like concentration and temperature [1–5]. If the laser energy coincides with a resonance in the medium a thermal grating appears due to absorption of pump radiation. A model for the intensity of a beam, diffracted of electrostrictive and thermal gratings can be found in [6]. Due to the interdependence of many parameters (e.g., the sound velocity depends on concentration and temperature) multi-parameter diagnostics is challenging. In this work we demonstrate the application of a four-wave mixing contribution to the LIG signal for simultaneous gas phase concentration and temperature determination.

## 2 Experimental section

A schematic representation of the experimental setup is shown in Fig. 1. The setup is designed to be robust and compact to be used in cramped test facilities. Therefore, only off-the-shelf lasers have been used. A flashlamp pumped Nd:YAG laser produces pulses at 1064 nm, 10 Hz and 42 mJ, which are used as the pump-beams. This output is guided through a half-wave plate to adjust polarization and is split in two by a beam-splitter. The forward scattered light from the half-wave plate is caught by a photodiode, which is used as a trigger for the signal detection. One of the pump beams is guided through a second half-wave plate for experiments with crossed pump-beam polarizations. The pump beams are overlapped in a heatable gas cell at an angle of about  $2^\circ$  using lenses with a focal length of 750 mm. The fringe spacing of the resulting LIG is about 31  $\mu\text{m}$ . The probe beams is provided by a continuous wave (cw), frequency doubled, diode pumped solid state (DPSS) laser (532 nm, 50 mW), which is guided through a half-wave plate and overlapped at an opening angle of  $0.5^\circ$  from the centerline. The signal is separated from pump and probe by beam dumps and a laser line filter. Additional local filtering is done by focusing the beam into an optical fiber. The signal is detected by a photomultiplier tube that is connected to an oscilloscope. The neat gases  $\text{CO}_2$ ,  $\text{N}_2$  and  $\text{CO}_2\text{-N}_2$  mixtures at 1 bar and 295 K and 375 K were probed. Typically, 500 single shots are recorded and averaged in the evaluation procedure. The detail on the evaluation procedure can be found in [7].

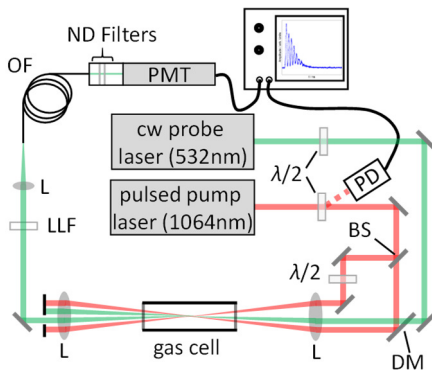

**Figure 1.** Schematic representation of the experimental setup: BS: Beam splitter, DM: Dichroic mirror, L: Lenses, LLF: Laser line filter,  $\lambda/2$ : half-wave plate, ND: Neutral density filter, OF: Optical fiber, PD: Photodiode, PMT: Photomultiplier tube.

### 3 Results and discussion

In LIEG measurements of  $\text{CO}_2$  and  $\text{N}_2$  are shown in Fig. 2. It can be clearly seen that the oscillation period of the signal amplitude is different for both gases. Furthermore, a strong peak appears in  $\text{CO}_2$  at  $t = 0$  ns that only has a small amplitude in  $\text{N}_2$ . Because of its dependence on the  $\text{CO}_2$ - $\text{N}_2$  mixture ratio the behavior of this peak may be used as a concentration probe, independent of sound velocity, which can then be applied for different parameters. To properly model the behavior of the signal shape and apply it for diagnostic purposes its nature needs to be elucidated. Due to its absence in nitrogen pump-laser straylight can be excluded and a resonant coherent effect like four-wave mixing is likely. Although a resonant (thermal) contribution to the LIG resulting from IR absorption can be excluded from fitting of the trace by the model from [6], there are very low cross-section resonances at the pump laser energy of  $9398 \text{ cm}^{-1}$ , which could promote a two-color four wave mixing (FWM) process.

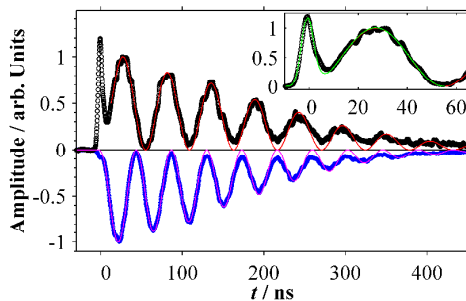

**Figure 2.** Amplitude of the diffracted beam of  $\text{CO}_2$  (black) and  $\text{N}_2$  (blue) as a function of time (500 averaged traces). The full traces have been fitted by the model function for LIGs from [1] (red and magenta respectively). The inset shows the first peak and the first LIG arc observed in  $\text{CO}_2$  which has been fitted by the model function to obtain the peak ratios (details in [7]) (green).

As additional proof for an FWM process the polarization dependence was probed as LIEG and FWM should exhibit different polarization dependences. The results of polarization dependent measurements are shown in Fig. 3. Since the density modulation comprising the LIG arises from interference of the pump-laser fields, crossed pump-beam polarizations (horizontal-vertical-vertical: HVV) do not lead to the formation of a LIG. Under these conditions the FWM signal amplitude is reduced, but not zero. Using vertical pump-beams and a horizontal probe beam (VVH), in contrast results in identical LIEG diffracted beam amplitude, but reduced FWM signal amplitude. Therefore, it can be safely assumed that the peak in fact arises from FWM. For quantification of the process an evaluation procedure has been developed that is in detail described elsewhere [7]. In brief the FWM peak and the first LIG arc are fitted by a Gaussian function and a squared sine function and their phase dependent crossterm respectively. The function yields the ratio of FWM and LIG in the form of the squared parameter  $R$  (displayed in Fig. 3).

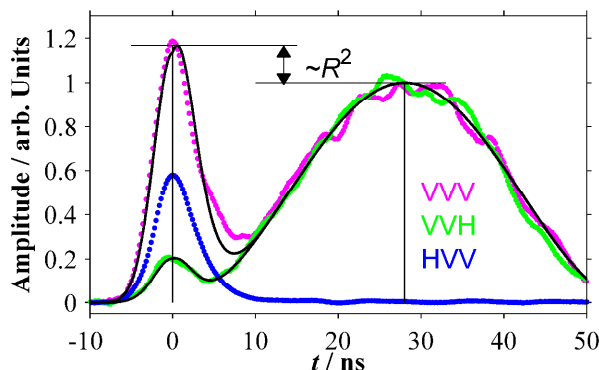

**Figure 3.** Plot of the amplitude of the diffracted beam as a function of time for three different polarization configurations: VVV: All-vertical, VVH: Vertical pump beams and horizontal probe beam, HVV: Horizontal pump-beam, vertical second pump and probe beams. The VVV and VVH traces have been fitted (black) by the model described in the text to obtain the parameter  $R^2$  as a measure for the FWM- and LIG-diffracted beam amplitude ratio.

Because of its dependence on the  $\text{CO}_2\text{-N}_2$  mixture ratio, the applicability of  $R$  as a probe for concentration was investigated. Fig. 4 shows the ratio of FWM and LIG signal amplitude  $R$  as a function of  $\text{CO}_2$  molar fraction for 295 K and 375 K. The ratio increases with  $x$  from about 0.4 to 1.15 in a nonlinear fashion. This increase is weaker for higher temperatures. Using this curve as a calibration,  $R$  can be used as independent parameter for the determination of  $\text{CO}_2$  concentrations in  $\text{CO}_2\text{-N}_2$  mixtures. The concentration can then be used to determine the temperature from the sound velocity, which is encoded in the oscillation period. Due to the temperature dependence of  $R$  calibration curves for different temperatures need to be known and the temperature determination must be done in an iterative fashion. A physically derived model of the behavior including a detailed study on the temperature dependence of  $R$  can be found in [7].

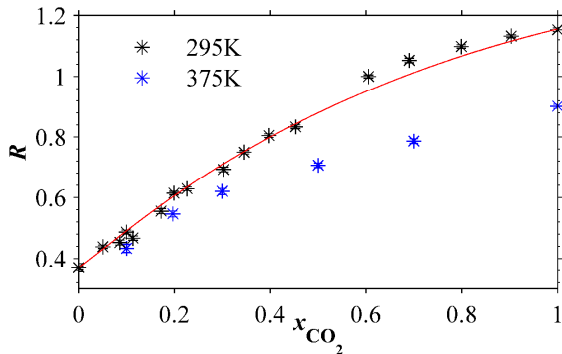

**Figure 4.** Plot of the parameter  $R$  (see text) as a function of  $\text{CO}_2$  molar fraction in  $\text{N}_2$  at 1 bar and 295 K (black) and 375 K (blue). The trace for 295 K has been fitted the model function from [7].

## References

- [1] A. Stampanoni-Panariello, D. N. Kozlov, P. P. Radi, and B. Hemmerling, “Gas-phase diagnostics by laser-induced gratings II. Experiments,” *Appl. Phys. B*, vol. 81, no. 1, pp. 113–129, Jul. 2005, doi: 10.1007/s00340-005-1853-y
- [2] J. Kiefer, D. N. Kozlov, T. Seeger, and A. Leipertz, “Local fuel concentration measurements for mixture formation diagnostics using diffraction by laser-induced gratings in comparison to spontaneous Raman scattering,” *J. Raman Spectrosc.*, vol. 39, no. 6, pp. 711–721, Jun. 2008, doi: 10.1002/jrs.1965.
- [3] A.-L. Sahlberg, D. Hot, J. Kiefer, M. Aldén, and Z. Li, “Mid-infrared laser-induced thermal grating spectroscopy in flames,” *Proc. Combust. Inst.*, vol. 36, no. 3, pp. 4515–4523, 2017, doi: 10.1016/j.proci.2016.07.017.
- [4] A. Luers, A.-L. Sahlberg, S. Hochgreb, and P. Ewart, “Flame thermometry using laser-induced-grating spectroscopy of nitric oxide,” *Appl. Phys. B*, vol. 124, no. 3, Mar. 2018, doi: 10.1007/s00340-018-6912-2.
- [5] F. De Domenico, T. F. Guiberti, S. Hochgreb, W. L. Roberts, and G. Magnotti, “Temperature and water measurements in flames using 1064 nm Laser-Induced Grating Spectroscopy (LIGS),” *Combust. Flame*, vol. 205, pp. 336–344, Jul. 2019, doi: 10.1016/j.combustflame.2019.04.016.
- [6] B. Hemmerling, D. N. Kozlov, O. M. Stel’makh, and B. Attal-Trétout, “Diagnostics of water-containing gas mixtures using thermal laser-induced gratings,” *Chem. Phys.*, vol. 320, no. 2–3, pp. 103–117, Jan. 2006, doi: 10.1016/j.chemphys.2005.06.048.
- [7] J. I. Hölzer, D. N. Kozlov, V. Bondarenko, and T. Seeger, “Diagnostic application of two-color four-wave mixing contribution to an electrostrictive laser induced grating signal in  $\text{CO}_2$ - $\text{N}_2$  mixtures,” *Appl. Opt.*, in preparation, 2022.





# Instagram for Information and Publicity Purposes During the Covid-19 Pandemic

Andi Poplas<sup>1,2</sup>, Nina Planinšek<sup>1,2</sup>, Miha Rušnik<sup>1,2</sup>, Rok Nabergoj<sup>1,2</sup>,  
Vili Podgorelec<sup>1,3</sup>, Ines Kožuh<sup>1,3</sup>

<sup>1</sup> Faculty of Electrical Engineering and Computer Science, Koroška cesta 46, Slovenia

<sup>2</sup> {andi.poplas, nina.planinsek, miha.rusnik, rok.nabergoj}@student.um.si

<sup>3</sup> {vili.podgorelec, ines.kozuh}@um.si

**Abstract.** *The Covid-19 pandemic has shaken the world and brought us new challenges such as spreading information. In today's social networks-dominated world, the public is commonly informed via Instagram, one of the fastest-growing networks. In our research, we looked at the said network for the purpose of spreading information to the public during the pandemic. We found that the majority of respondents do not use Instagram for gathering information about Covid-19. However, the level of awareness of its users increases as the number of perceived posts related to the Covid-19 pandemic increases. We found that older users are more informed, and that individuals obtain information from different types of profiles. We concluded that Instagram is still a good tool to inform users, as it reaches a certain level of people and informs them well about Covid-19 and can be used with advantage by organisations and individuals for sharing information.*

**Keywords.** Instagram, information, publicity, crisis, Covid-19

## 1 Introduction

In times of crisis, such as the Covid-19 pandemic, the question of how to ensure that citizens are as well informed as possible about the situation and how to deal with it arises repeatedly. The ways in which the public is informed have changed and adapted over time and with the development of different technologies, and, in recent years, communication on social networking sites has been gaining ground.

Social networks, which have developed rapidly over the last two decades, allow users to connect with each other without time and space constraints [3]. Such networks, of which Instagram is one, can be used to keep citizens informed in crisis situations.

This topic has already been addressed by other authors. The authors of the studies we have reviewed have been dealing with the role of social networks and activities on these networks in their own settings, i.e. in different countries during the Covid-19 pandemic, and the impact of social networks on pandemic information.

Our study will help to understand better the state of information on the Covid-19 pandemic and the problems associated with the way this topic is communicated on Instagram. The knowledge gained will ease the work of the services responsible for raising public awareness in the event of future crisis situations. It will also help to understand the extent to which users obtain this type of information from social networks, and the extent to which they trust it.

## 2 Conceptual framework

Over the past decade social networks have become a crucial part of our everyday life, impacting economics, politics and society itself importantly. In contrast with the rise of social networks, traditional media, such as television, radio and newspapers, have declined in importance [18]. According to Hu and Ling [17], social networks have four major advantages over traditional media, which are only increasing as they evolve. These are integration, time efficiency, low resistance and orderliness.

Social networks are an important source of information for many people, which carries the risk of potential misinformation and misleading information. To avoid this, we need to pay attention to peer-reviewed and verified information, as misinformation can lead to major problems in certain situations [4].

Instagram is one of the many popular social networks that have taken the world by storm in the last decade. This is proved by its 1.1 billion global users [11]. To view, post and interact with posts and stories of other users, users have to be registered, thus creating a profile on the said social network [5]. The profile can be either public, which makes it visible to all Instagram users, or private, which makes it visible only to users who have been pre-authorised by the profile owner to follow and, thus, view the profile.

---

Users can post content of various types on the network. The most common are posts, the content of which is in the form of images or short videos. Stories are another type of content that offer additional information and communication. A story is content shared between Instagram users, and is only visible for one day unless it is saved among the so-called highlights. The third type of content is IGTV (Instagram television), which allows the posting of longer clips [20]. Users can respond to content in the form of posts with likes and comments, with messages, or a like in the form of direct messages, and interact with interactive elements and respond to messages in the case of stories [12].

Today, many well-known individuals, multimedia houses and government portals are already part of Instagram. Thus, we can also divide authors by type into individuals, news portals, government portals, and portals dealing with specific topics. The authors of the content use the network to share events and thoughts from their lives, inform the public about current events, and publish entertaining and educational content [5].

In 2020 content regarding Covid-19 became widespread on Instagram following the outbreak of the pandemic. The Covid-19 pandemic initially hit China at the end of 2019, but took global proportions a year later. The WHO declared the spread of the virus a pandemic, underlining the gravity of the situation, and calling on the public to take action in detecting and containing the spread of the virus [8]. Therefore, countries introduced various measures, such as emphasis on hygiene, social distancing and the introduction of quarantines. Many countries and organisations have also resorted to social networks to communicate taken measures and to inform about the spread of the virus.

Informing the public about the pandemic was crucial, as it allowed people to increase control over their own and others' health. It focused both on individuals' behaviour change and disease management, and interventions that impact organisations and communities, and, at the higher level, by informing policies that affect populations [13]. In times of crisis, people want to be well informed so that they know what specific preventive measures they need to take and how they can cope with the consequences. Information on the Covid-19 virus is abundant, with official and unofficial websites and media portals updating recommendations, guidance, and reporting on the current situation regularly. Bombarding communications, even if well planned, can cause confusion. As information about the virus is also spread via social networks, there is an additional risk of spreading false information that some people take as truth. These misconceptions can be reinforced by the false consensus that is created when information is shared on social media, leading to an 'illusion of truth' effect, meaning that information that is repeated often is more easily taken as true [9].

### 3 Methodology

#### 3.1 Variables, research questions, hypotheses and research model

Through a literature review, we set out to answer the following research questions:

- Does the average number of detected Covid-19-related posts help to inform individuals better about the Covid-19 pandemic?
- Does the age of an Instagram user affect the level of awareness of the Covid-19 pandemic?
- Does the level of education of an Instagram user influence the level of awareness of the Covid-19 pandemic?
- Do different types of Instagram posts on Covid-19 have a different impact on the level of information individuals have about Covid-19?
- Does the type of author of Instagram posts about Covid-19 have an impact on the level of information people have about Covid-19?

#### 3.2 Sampling, participants, research process and measuring instrument

We used convenience sampling, which is a basic type of sampling. Participants were selected according to their availability, as we did not have the option of selecting individuals. We sought them randomly by sharing our survey across different media. Finally, we used a personal approach, by approaching individuals and asking them to complete our survey. The participants were, thus, completely random.

The research was carried out by defining the theoretical framework, research questions and hypotheses. Based on that we created a research model and the measurement system across the survey.

The research questions were used to analyse the statistical data obtained from the research design (survey). In order to obtain data to answer the research questions, we conducted a survey, which we designed in an online format using the 1KA online service. The survey consisted of three parts filled with questions and a conclusion. The first part of the survey measured knowledge related to Covid-19 (symptoms, transmission, preventive measures and alleviating its symptoms), in the second part we collected data from the respondents regarding the use of Instagram, and in the third part of the survey we collected the demographic data of the respondents. At the end of the survey, we invited all respondents to a possible interview, which we would conduct if we had enough candidates.

## 4 Results

Of the 88 respondents, the second part of the survey, which included questions related to the use of Instagram in connection with posts related to the Covid-19 pandemic, was completed by only 36 respondents.

For the first part of the analysis we analysed the impact of the average number of detected Covid-19 publications on user awareness. We first performed a test of normality of the distribution for information. The Shapiro-Wilk test was used to test for normality. The test showed a characteristic statistical correlation to an abnormal distribution of data,  $p < .001$ . Due to the abnormal distribution, we used the Kendall rank correlation coefficient, which is a nonparametric test, to determine the strength and direction of the linear relationship between the ordinal or continuous variables. Using the Kendall rank correlation coefficient, we examined the relationship between the average number of detected Covid-19-related publications per day on the network and the level of awareness that respondents achieved by solving the test. The correlation between the variables was positive and statistically significant,  $\tau_b = .28$ ,  $p = .026$ . The level of information of users about the pandemic also increased with the increase in the number of detected posts related to the Covid-19 pandemic on the Instagram network .

Next, we analysed the impact of the age of Instagram users on pandemic awareness. In this case, the distribution normality test was performed at the level of responses of 36 respondents. We used the Shapiro-Wilk test, which showed no statistically significant correlation, and, thus, an abnormal distribution of data,  $p < .001$ . We used the Kendall rank correlation coefficient to determine the relationship between user age and Covid-19 pandemic awareness. The correlation between the mentioned variables was positive and statistically significant,  $\tau_b = .40$ ,  $p = .004$ . The older Instagram users are, the higher their level of pandemic awareness.

In the level of education achieved we found that, due to the abnormal distribution, we used the Kendall rank correlation coefficient to determine the relationship between the level of education of the respondents and their level of awareness of the pandemic. The correlation test did not show a statistically significant association between the variables,  $\tau_b = .08$ ,  $p = .574$ .

The type of publication on Instagram was related to the level of information. The test did not prove statistically significant,  $p < .001$ . We used the Kruskal-Wallis H test to check the impact between the type of posts surveyed by respondents on the social network Instagram and the level of their awareness. The test result showed no statistically significant effect between the type of Covid-19-related posts on Instagram and the level of user awareness of the pandemic,  $X^2(2) = 0.059$ ,  $p = .971$ .

The influence of the type of author of Instagram posts monitored by the respondents on the level of their awareness of the Covid-19 pandemic was checked with the Kruskal-Wallis H test. The latter showed a statistically significant effect between the type of author of Covid-

19-related posts on Instagram and the level of user awareness of the pandemic,  $X^2(6) = 16.2$ ,  $p = .013$ , with an average level of information of 12.5 for acquaintances (friends, relatives), 11.07 for influencers, 24.25 for public figures (politicians), 23.95 for news portals, 32.50 each for government portals and organisations and 12.91 for portals dedicated to the Covid-19 pandemic.

## 5 Discussion

The Covid-19 pandemic presented a unique challenge that the modern world has not yet faced. That's why it's important to know how to inform the public effectively about the pandemic and what is happening.

In our research we have focused on a key concept in information dissemination today; social networks. We chose Instagram as the subject of our research, as it is one of the most used networks today, especially in our environment. In our research, we wanted to find out to what extent the public obtains information about the Covid-19 pandemic on Instagram compared to other media channels, and we also wanted to know whether they perceive the information they obtain on Instagram as credible.

Based on data from the survey we found that characteristics such as age and attained age of the Instagram user do not influence the awareness of the Covid-19 pandemic. Moreover, neither the type of Covid-19-related post, nor the time spent on Instagram has any impact on awareness.

We found that the type of author of a post has an impact on pandemic awareness; government portals and organisations have the highest impact, while influencers have the lowest. In addition, the number of perceived Covid-19-related posts on Instagram also influences pandemic publicity.

Comparing our results with previous related studies, we can conclude that our results are relevant. Saud, Mashud and Ida [10] also concluded in their study that their target population found social media useful in gathering information about the disease. Alnasser et al. [1] in their study found that the most common source of information on the Covid-19 pandemic on social media was government portals; it is this type of profile that has the highest impact in our country of all the profiles considered. Goodyear et al. [7] showed in their study that the use of social networks promoted healthy behaviour, and increased the potential of participants. In our study, we demonstrated that Instagram users were better informed about the pandemic if they consumed more posts, suggesting a positive correlation.

Our results and findings can help us to understand the importance of social networks better, and help us to communicate on these networks. This knowledge can be useful in everyday communication, but is even more important in times of crisis, when effective and efficient communication with society is even more important for crisis resolution and management. Communication via social networks has features and elements that are useful and crucial in times of crisis, and it would be absurd not to use technology and its benefits

to our advantage in order to overcome crisis situations more quickly, as the Covid-19 pandemic certainly was.

## 6 Conclusion

Through our study we wanted to find out to what extent the public was getting information about the Covid-19 pandemic on Instagram and how this compared to other media. The aim of the study was to provide statistics to understand better the state of communication, and to present an overview of the optimal way to share information in a crisis situation that individuals can trust.

The contribution of our study is statistical information on how Instagram users acquire information related to the Covid-19 pandemic. Through statistical analysis we found that, as the number of perceived Covid-19-related posts increases, so does the level of user awareness of the pandemic. A related finding is that, as the age of the user increases, so does the level of awareness of the pandemic. In relation to age, education level was not found to have a significant impact on the level of awareness of users, but the type of author of the post was an important factor, as the analysis showed a correlation between the type of author of Instagram posts and the level of awareness of users.

All findings are available to Instagram users who post pandemic-related content. Our analysis allows them to change the audience for which the information is intended, and to share it only with that group of individuals. They could also use the results of the analysis to tailor the types of posts and focus on certain types of authors as a community. It can also be helpful for all researchers analysing or researching audience information about the Covid-19 pandemic on the web.

The biggest limitation of our research is the accuracy of the results, as the diversity of the respondents was important in the data collection, but this was limited, as we mostly selected citizens of Slovenia and members of the same cultures. Another limitation, in our view, was the lack of cooperation with Instagram or their partners who deal with statistical analysis of users on the social network, as they would be able to answer our questions directly. As a third shortcoming, we point to the use of a simple questionnaire that could be upgraded.

In the future, we could extend our research by using more measurement instruments. We could also run an experiment in conjunction with the survey, which would be adapted according to the statistical results of the survey. The experiment would then be used to confirm or refute some of the results. Similarly to the experiment, interviews would be conducted with the respondents to obtain detailed explanations as to why these results were obtained. Despite the potential for extension, the analysis has generated important data that can be used in further research on how individuals are informed about Covid-19.

---

## References

- [1] Alnasser *et al* “The positive impact of social media on the level of COVID-19 awareness in Saudi Arabia: a web-based cross-sectional survey,” *Le infezioni in medicina*, vol. 28, no. 4, pp. 545–550, Dec. 2020. [Online]. Available: [https://www.researchgate.net/publication/346841047\\_The\\_Positive\\_Impact\\_of\\_Social\\_Media\\_on\\_The\\_Level\\_of\\_COVID-19\\_Awareness\\_in\\_Saudi\\_Arabia\\_a\\_Web-Based\\_Cross-Sectional\\_Survey](https://www.researchgate.net/publication/346841047_The_Positive_Impact_of_Social_Media_on_The_Level_of_COVID-19_Awareness_in_Saudi_Arabia_a_Web-Based_Cross-Sectional_Survey) (accessed Mar. 5, 2022)
- [2] W. Antonelli. “A beginner's guide to Instagram, the wildly popular photo-sharing app with over a billion users.” *BusinessInsider.com*. <https://www.businessinsider.com/what-is-instagram-how-to-use-guide> (accessed Mar. 5, 2022)
- [3] N. Barrett-Maitland, N. and J. Lynch, “Social Media, Ethics, and the Privacy Paradox,” *Security and Privacy From a Legal, Ethical, and Technical Perspective*. London, United Kingdom: IntechOpen, 2020 [Online]. Available: <https://www.intechopen.com/chapters/70973> doi: 10.5772/intechopen.90906 <https://doi.org/10.5772/intechopen.90906>
- [4] K. Chan, C. P. Nickson, J. W. Rudolph, A. Lee and G. M. Joynt, “Social media for rapid knowledge dissemination: early experience from the COVID-19 pandemic,” *Anaesthesia*, vol. 75, no. 12, pp. 1579-1582, Mar. 2020, doi: 10.1111/anae.15057.
- [5] J. Cook, *Instagram Rules: The Essential Guide to Building Brands, Business and Community*. London, UK: White Lion Publishing, 2020
- [6] F. de Véricourt, H. Gurkan and S. Wang, “Informing the public about a pandemic,” *SSRN Electronic Journal*, Dec. 2020, doi: 10.2139/ssrn.3749146.
- [7] V.A. Goodyear *et al* “Social media use informing behaviours related to physical activity, diet and quality of life during COVID-19: a mixed methods study,” *BMC Public Health*, vol. 21, no. 1, Jul. 2021, doi: 10.1186/s12889-021-11398-0.
- [8] R. Güner, I. Hasanoğlu, and F. Aktaş, “COVID-19: Prevention and control measures in community,” *Turkish Journal of medical sciences*, vol. 50, no. 1, pp. 571-577, Apr. 2020, doi: 10.3906/sag-2004-146.
- [9] K. C. Santosh and A. Joshi, *COVID-19: Prediction, Decision-Making, and its Impacts*, Singapore: Springer, 2020.
- [10] M. Saud, M. Mashud and R. Ida, “Usage of social media during the pandemic: Seeking support and awareness about COVID-19 through social media platforms,” *Journal of Public Affairs*, vol. 20, no. 4, Dec. 2020, doi: 10.1002/pa.2417.
- [11] Statista Research Department. “Instagram – Statistics & Facts.” *Statista.com*. <https://www.statista.com/topics/1882/instagram> (accessed Mar. 5, 2022)



- 
- [12] The Logo Creative. “Tips to Use Instagram as a Graphic Designer.” Medium.com. <https://thelogocreative.medium.com/tips-to-useinstagram-as-a-graphic-designer-c4889e894376> (accessed Mar. 5, 2022)
- [13] S. Van den Broucke, “Why health promotion matters to the COVID-19 pandemic, and vice versa”, *Health promotion international*, vol. 35, no. 2, pp. 181-186, Apr. 2020, doi: 10.1093/heapro/daaa042.
- [14] “Explained: What is Instagram?” Webwise.ie. <https://www.webwise.ie/parents/explained-image-sharing-app-instagram/> (accessed Mar. 5, 2022)
- [15] S. Weston and M. B. Frieman, “COVID-19: Knowns, Unknowns, and Questions,” *mSphere*, vol. 5, no. 2, Mar. 2020, doi: 10.1128/msphere.00203-20.
- [16] R. M. Jaber, B. Mafrachi, A. Al-Ani and M. Shkara, “Awareness and perception of COVID-19 among the general population: A Middle Eastern survey,” PLOS ONE, vol. 16, no. 4, Apr. 2021, doi: 10.1371/journal.pone.0250461.
- [17] D. Ling and H. Hu, “Feature analysis of the social media,” Proceedings of the 2013 International Workshop on Computer Science in Sports, pp. 186-190, Aug. 2013, doi: 10.2991/iwcss-13.2013.50.
- [18] L. McCay-Peet and A. Quan-Haase, “A Model of Social media Engagement: User Profiles, Gratifications, and Experiences,” *Why Engagement Matters*, pp. 199-217, May 2016, doi: 10.1007/978-3-319-27446-1\_9
- [19] B. Stegner. “What is Instagram and How Does it Work?” MakeUseOf.com. <https://www.makeuseof.com/tag/what-is-instagram-how-does-instagram-work/> (accessed Mar. 9, 2022)
- [20] M. Karle, *A Social Media Survival Guide: How to Use the Most Popular Platforms and Protect Your Privacy*, Rowman & Littlefield, Feb. 2020



# Living the Culture through the *Commoning*

Daniele Paragano<sup>1</sup>, Giada Semeraro<sup>2</sup>

<sup>1</sup> Professor at Economic Geography

Niccolò Cusano Telematic University of Human Sciences, Department of Economy  
Daniele.paragano@unicusano.it

<sup>2</sup> Student contribution

Niccolò Cusano Telematic University of Human Sciences, Department of Economy  
Semerarogiada@gmail.com

**Abstract.** *Cultural heritage is the legacy of sites, things, traditions and practises a society regards as worthy of conservation. The purpose of this paper is to explore how we can take advantage of the Cultural Heritage materials through the processes of commoning. The importance of Cultural Heritage, together with the transfer of its values, must pass through a well-rounded cultural education, relying on lifelong and continuous learning that contributes to building a collective awareness of the topic. So, Cultural heritage can be considered an important development resource: the measures to take in order to enhance the role of Cultural Heritage include collective projects linked to the environment of the territory and the symbols connected to it. For this reason, the joint intervention of public and private entities, the cultural sector and the third sector is needed for an overall participatory enhancement and the creation of integrated cultural paths.*

**Keywords.** Commoning, education, growth, cultural, resources, territory

## 1 Introduction

Cultural heritage includes artefacts, monuments, a group of buildings and sites, museums that have a diversity of values including symbolic, historic, artistic, aesthetic, ethnological or anthropological, scientific and social significance. It includes tangible heritage (movable, immobile and underwater), intangible Cultural Heritage (ICH) embedded into cultural, and natural heritage artefacts, sites or monuments. [12]

The purpose of this paper is not to investigate all these meanings. Rather, the purpose is related to the role of Cultural Heritage as an expression of the ways of living developed by a community and passed on from generation to generation, including customs, practices, places, objects, artistic expressions, and values. [2] Most social scientists emphasise the heritage functions for supporting ethnic, national, and elite interests and it is important to consider the heritage a common good. The "common goods" have a fundamental importance in the relationship between a territory and the culture to which they belong, as they are the object of a strong production of practices and meaning by different movements and social groups. [6] This poses a number of social and economic questions beyond the immediate question of how much are people willing to pay to consume (use, see, experience) different cultural goods. First of all: how is a collective identity built? What are the practices to be carried out? What role does communication play? Are there differences in preferences and utility for cultural goods with physical and social distance? The paper will show how these questions can inform Cultural Heritage management decisions.

## 2 Background

When we talk about "heritage" (both in the natural and cultural sense) we immediately think about contemplation, aesthetic enjoyment, the need to preserve it and pass it on to future generations as well. In truth, this is only a small fragment of what should be considered.

Material and intangible heritage are closely related. All intangible aspects such as knowledge systems, the principles of action or the values and beliefs of man, cannot be considered as heritage if they cannot be shared. Also, material or tangible heritage reaches its full significance when it refers to the knowledge and values that constitute its essence, and give meaning to its production. [3]

The identity of a community is inevitably linked to its geography, its buildings, its history and its leaders. [8]

The characteristics of each territory tend to be incorporated within symbolic meanings.

The geography itself fits into a metaphorical description of the territory, made up of symbols created and transformed by the culture to which they belong and which gives life to experiences of common growth.

Some examples are: *Mount Kailash*, in Tibet; It is sacred three times (Buddhists, Hindus and Jains) and it is considered *Azis Mundi* (center of the universe). *Glastonbury Tor*, in

---

England, *the Sedona Vortices* in Arizona or *Crater Lake* in Oregon, already dear to the Klamath Native American tradition.

The geographical analysis of the territorial context helps to grow the sentiment and spatial ideas of man in the overall experience. In order to take care of places, it is necessary to know how to interpret values, identity, ways to communicate and know how to value an asset.

From a social and critical perspective, it is therefore possible to underline the performative dimension of geography which, on the basis of physical space, produces places and territories, also through their use and their dialectical construction.

The constant production of space calls attention to the continuity of social events and, then, reinforces the need to overcome the museum dimension, which in the classical sense presupposes a hibernation of a place in a time, to focus attention on how the elements of Cultural Heritage and their use participate in the construction of contemporary societies.

This is why it appears necessary to highlight the importance of reflecting on the scalariness of the theme, from a geographical point of view and in line with the overall reflection of the article. Although there is a frequent tendency to define and spatially limit a social phenomenon, delimiting its relations and influences is almost impossible. This, although valid for the physical elements, is even more evident for the immaterial aspects which, physiologically, constitute a spatial *continuum*. From this also derives the complexity, conceptual and operational, in the determination of the actors assigned to the management of Cultural Heritage which, obviously, cannot be defined only on a spatial basis.

Good communication of Cultural Heritage develops community building strategies that bring together the world of culture, the socio-economic fabric, the world of research and citizenship as a whole, enhancing the tangible and intangible assets that characterise the territory that surrounds us. The Cultural Heritage, in fact, represents one of the most strategic communicative resources for building and strengthening the territorial identity through the involvement of all the different stakeholders who populate it. Communities are the main actors in the formation of the culture of their territory; In fact, the formation of culture is a process in continuous development and it never stops. Quoting the Chinese-American geographer Yi-Fu Tuan, «*It is the people who create the places*». [11]

Cultural Heritage certainly plays a key role in local development processes, because it is able to facilitate the building of relationships and can allow the development of integrated territorial transformation policies, and new virtuous economic sectors capable of producing income to be reinvested in services and improve the quality of life for local communities. These objectives are decidedly demanding to achieve and involve strong social cohesion and new actions of empowerment on the part of individuals towards the care and management of the "common good", of their "cultural landscape".

Considering the Cultural Heritage as an element in support of the local economy, it is necessary to question the process of social construction and therefore evaluate the set of existing values in the territory. This means taking advantage of living culture as the setting for cultural growth. The concept of *living culture* is at the centre of any process of cultural and global development. As taught by Roland Colin, a student of L.J. Lebrét in the sixties, «*it is only in full possession of their own culture that a people can be responsible for their*

*own development. Development can be defined for a people only by the people themselves, in the language of their culture*". [3] These words highlight the sense of community commitment to development, a sense that must be shared, understood, inherent in the culture of every place and belonging to every group.

### 3 Practices and horizon for the development of common spaces

In order to exploit a territory's energy as better as possible, we should ask ourselves "why" a good exists and "why" it allows you to satisfy a certain need and whose usefulness is reflected in the community (living, remembering, eating, practising a religion...) Secondly, we should ask "how" engage the crowd by lowering targeting barriers.

Each cultural good can serve many things together, depending on the state and local development: the contribution of the historian Hugues de Varine [3] in this regard helps us to better understand this discussion. From his lessons it clearly emerges that talking only about cultural consumption is not enough to guarantee (social and economic) development, because the consumption of this heritage will benefit a small number of people. In order to consider it as a real resource, it must be made available to all and to the entire development process (meaning that it should be destined not only to culture or tourism, but to society as a whole, therefore to the economy, education, identity, employment...)

Among the many forms of utility we certainly find research activity, especially university, thanks to the propensity that certain territories have to favour such study circumstances.<sup>1</sup> [5]

The forms of utility of each territory determine the action plan. But which elements of a territory should be considered wealth and which not? This question is fundamental because it introduces a careful selection process that is reflected in both tangible and intangible assets. This process must also consider the historical and social evolution of peoples, the continuous changes and cultural developments (both positive and negative).

The starting point is the analysis of places and the understanding of how culture is concentrated in different territorial contexts: in fact, the common good is built not so much as an object or as a social process, but as an unstable and malleable relationship between a specific (social) group and the aspects already existing or yet to be created of the physical environment or essential relationships. This relationship has a name: we really talk about *commoning*. [7] This term is perhaps one of the few that does not have a literal and precise translation, as it usually refers to real concrete practices that aim to enhance "everything we have in common" starting from sharing problems and approaches to the territory. [4]

The theory of common goods, in a nutshell, was developed in the 1960s starting from the studies of Garrett Hardin and subsequently deepened by the research conducted by Elinor

---

<sup>1</sup> In Brazil, the presence of a wide area of the Atlantic forest has made it possible to use considerable funding for local development by international organisations interested in the study of the biosphere. The Maestrazgo Natural Park, in Aragon, is testimony to how the living culture of the territory manages to be a key factor of development. [5]

---

Ostrom on common goods. These theories have materialized in different ways in practice, from direct action by citizens to dialogue with institutions. Movements of regeneration have begun from below, born not only with the idea of regaining possession of the spaces but with the intention of safeguarding them. [5]

Districts, universities, open source communities, living labs, co-working environments, are ideal places on which to base opportunities for exchange, a continuous give-and-take that makes the basket of practical knowledge spread patchy. This attitude leads to the maturation of a creative habitat with the following characteristics: human capital, continuous learning, proximity both in geographic and cognitive meanings. [1]

The theme of the governance of common goods meets the theme of competitiveness and innovation and is a favourable ground for promoting collaboration with the recipients of a service. The underlying fact is to create a society where institutions facilitate and support collective action and develop opportunities for interaction; the local community adopt cooperative behaviors in the configuration, for example, of common rules for the use of the property. In the inclusion of experiences for the community, the inclusion of sites, of symbolic places - such as those mentioned above, the strategic location of resources - must be carefully considered: creating a more intense network would also distribute the same benefits more homogeneously. [8] [10]

In conclusion, Cultural Heritage proves to be an interesting driver of development from different points of view: among measures to be taken to enhance the role of Cultural Heritage local strategies are very important which, exploiting the concept of proximity, they can activate forms of sustainable tourism in the area and projects related to the environment. [9]

For the success of these objectives, it's important to rely on the joint intervention of public organizations and the private sector, the cultural sector, education and the third sector; it is needed an overall participatory enhancement and the creation of integrated cultural paths, involving more important cultural realities than others with less power of attraction or with difficulties.

By ensuring operational support for the planning of "good practices" aimed at cultural and tourist development, it is possible to orientate oneself even better with a view to a shared enhancement of all the resources that make up the identity of a territory.

## Acknowledgments

The work is the result of a common reflection. For the Italian evaluation purpose *Giada Semeraro* takes responsibility for sections 1, 2, 3 and *Daniele Paragano* takes responsibility for section 2.

## References

- [1] Bertoincin M., Faggi P., Paese A., Quatrida D., *La prossimità: una chiave geografica per interpretare I progetti di sviluppo*, AGEI – Geotema.
- [2] Brumann C., *International Encyclopedia of the Social & Behavioral Sciences* (Second Edition), 2015.
- [3] Colin R., *Signification du développement, Développement et civilisations*, June 1968, p.11
- [4] Craterre-ENSA G. *Cultural Heritage & local development*. Convention France-UNESCO, 2006.
- [5] De Varine H., *Radici del futuro*. Il patrimonio culturale al servizio dello sviluppo locale. Clueb, 2005.
- [6] Feliciantonio, C., & Aru, S., *Dai Commons al Commoning (urbano): Pratiche e Orizzonti Politici Nel Contesto Mediterraneo*, ACME: An International Journal for Critical Geographies, 2018.
- [7] Fuschi M., Evangelista V., *Il paesaggio urbano come processo di commoning: una lettura geografica – Aa.Vv.* (2016), Commons/Comune, Società di studi geografici. Memorie geografiche NS 14, pp.227-233
- [8] Menaghi A., *Il territorio come soggetto di sviluppo delle società locali*. Report of the International Conference, organized by the University of Macerata, Falconara Marittima, 8/9 novembre 2006; [www.dea.univr.it](http://www.dea.univr.it)
- [9] Rallet A., Torre A., *Is Geographical Proximity necessary in the Innovation Networks in the Era of the Global Economy?* GeoJournal, pp.373-380, 2000.
- [10] Torre A., Gilly J.P., *On the analytical dimension of proximity dynamic*, Regional Studies, 169-180, 2000.
- [11] TUAN Yi—Fu, *Space and Place, The perspective of Experience*, University of Minnesota Press, Minneapolis 1977
- [12] UNESCO, *2009 UNESCO Framework for Cultural Statistics*, Institute for Statistics Montreal, Quebec, 2009.



# Social Media as a Channel for Cooperation, Co-creation and Communication between Companies

Daša Kompan<sup>1,2</sup>, Kim Obaha<sup>1,2</sup>, Nina Pahič<sup>1,2</sup>, Sabina Trop<sup>1,2</sup>,  
Vili Podgorelec<sup>1,3</sup>, Ines Kožuh<sup>1,3</sup>

<sup>1</sup> Faculty of Electrical Engineering and Computer Science, Koroška cesta 46,  
Maribor, Slovenia

<sup>2</sup> {dasa.kompan, kim.obaha, nina.pahic, sabina.trop}@student.um.si

<sup>3</sup> {vili.podgorelec, ines.kozuh}@um.si

**Abstract.** *The growth of social media and its interactivity and different communication functions represents a big opportunity for companies to conduct successful business. The communication of B2B companies on social media offers a range of different ways of connecting companies with each other and their customers successfully. Companies need to be careful with their social media presence, because having many different communication channels can cause their customers to feel confused and oversaturated with information. Our research has shown that B2B companies use social media to lower costs, remove geographic and time related boundaries, reach a bigger audience and personalise their customers` experiences. Functions that enable feedback (comments, likes, messages, ...) have an important role in social media and B2B communication. This helps companies recognise the needs and wants of existing and potential customers. Therefore, they can adapt their product to suit their target audience better.*

**Keywords.** Social media, entrepreneurship, business communication, co-creation, B2B

## 1 Introduction

Social media use algorithms to show their users the content that they like, therefore the use of these platforms has become an inevitable part of everyday life. Due to their large userbase social media became a good advertising medium, and many companies take advantage of that fact [1, 2]. In this research project we focused on different factors and problems which are being faced by companies that use B2B communication. The advancement of technology enabled many new ways of online content distribution. Researchers have already made studies about how companies advertise on social media, how they communicate with their users and customers, and how B2B companies communicate on social media [3]. Juntunen and others [4] have researched how B2B companies use the social media network Twitter for advertisement. Their research concluded that the most popular B2B companies on the social media network Twitter, among others, also include FedEx, Microsoft, Shell and Siemens [4]. In his research, Buratti [5] concluded that social media represent an easily accessible and cheap opportunity to gain a competitive advantage, even in conservative branches. Above all, his research concluded that social media are a modern channel for the implementation of B2B communication. During the process of obtaining literature, we focused mostly on scientific papers that have been published in different scientific magazines. In our search, we used advanced search, where we first defined the search string and then the period during which the work was published. We formulated the search string based on the key words and title of our research paper. We were looking for literature which focuses on the role of social media in business communication, social media in business-to-business cooperation and social media as a modern form of doing business. A problem often faced by companies during B2B communication is their use of many different social media platforms simultaneously, which confuses their potential customers. Communicating on many different social media platforms can represent a weakness, although in some cases it can be used to a company's advantage. The objects of our research are going to be the social media platforms Facebook, Instagram, YouTube and Twitter. We are going to research different ways and strategies of B2B communication inside separate social media platforms.

## 2 Theoretical frameworks

### 2.1 Business to business

Magar [6] defines business to business or inter-enterprise cooperation as » a situation, where one company enters into a market transaction with another company, for example, between a producer and a wholesaler« (str. 6). B2B strategy includes the satisfaction of the needs of other companies for the demand of the goods and services that they provide, that will satisfy the needs of the consumers [7]. The focus of B2B companies is shifting rapidly. They are focusing more on their image on social media platforms, as that represents a new source of income and new customers [6]. The most often used methods of B2B application in terms of

---

social media networks are posting content on a company blog, building relationships with bloggers, groups and influencers, and posting publicly accessible content online [2]. These methods help attract new customers, build relationships, and increase brand recognition, which is essential for a B2B strategy on social media networks. B2B oriented companies need a specific kind of consumers; therefore, a part of their social media marketing method is the posting of content that caters to a narrow audience, which is interested in, and willing to watch, informative and educational content. Consumer trust plays a big role in a long term relationship between the consumer and the company; therefore, it is very important for a B2B company [8, 9]. A good brand reputation results in customers trusting the brand's quality, and research has proven that customers are willing to pay a higher price and are more loyal and trusting to such a company. Therefore, each B2B company should stride to gain a good brand reputation [1].

## 2.2 Social media

Social media enable us the creation and exchange of user created content. Even though big and popular social media platforms such as Facebook exist and cover most of the needs a user has, there are many different platforms, that usually have different target groups, functionality, structure and social orientation [3]. The social media platform Facebook was created in 2004 with the purpose of connecting the students at Harvard university together, and, later, it's use spread around the world [10]. When a company creates its profile on a social media platform it offers potential customers an easier access to information. At the same time this is also an easy way to reach a large number of users [11].

Instagram is a social media platform that was launched in 2010 with the purpose of sharing visual content. Companies that want to succeed on that platform often collaborate with other users, that can be internal, created by the same company, or external – influencers and consumer businesses [8, 12]. YouTube is a social media platform that was founded in 2005 for the purpose of uploading and sharing videos. Many corporations use their YouTube channels for the distribution of their videos, advertisements and promotional products, with the purpose of reaching a wider audience and new business partners [13]. The social media platform Twitter was founded in 2006, and it focuses on the service of microblogging. The main function of this social media platform is that it distributes messages in real time (tweets), and users can share these messages on their own profile. The inclusion of consumers in the communication and their awareness can be increased with the use of this platform in B2B communication [14].

## 3 Methodology

The research method used to gather the information in this study is a case study with a thematic content analysis, the type of study is a volume review. Inside the literature we will look primarily for qualitative information related to B2B communication in social media. We

will decide the adequacy of information based on our defined variables and the research questions asked.

### **3.1 Identification of the research question**

As our research method we have chosen to do a case study, where we conducted an analytic review of the literature. We have set ourselves the following research questions: Did the way of B2B communication change due to the creation of social media? How does the frequency of social media use effect the success in B2B communication? How do different types of social media affect the success of B2B communication?

### **3.2 Identification and selection of relevant studies**

We began to search for relevant literature by preparing a search string that is made up of key words for our research topic. To find the necessary material we looked in the following databases: Science Direct, Springer Link, ProQuest, Research Gate. We gained access to them through the data base of University of Maribor: UM-NIK. We limited our material search to the time from 25<sup>th</sup> November 2021 to 20<sup>th</sup> December 2021, when we performed the primary data collection. We performed another round of data collection due to a lack of relevant conclusions; this round went on from the 1<sup>st</sup> to the 15<sup>th</sup> of January 2022. Before we reviewed our collected literature, we decided on a set of criteria which we used to select the appropriate studies. Our criteria included: Material that has been written in the English language; scientific or research papers; research papers that are based on case studies; research papers that study B2B communication on social media and address at least one of our defined groups; the last criteria were the disciplines or areas in which we searched for our literature. These included: Business, journalism, and communications. From all the collected literature we removed all the works that were not written in the English language, were not scientific papers, studies that did not include B2B communications or at least one of our defined groups, and all material that had been published before the year of 2011.

### **3.3 Data display and collection, summary and reporting our results**

Based on our research questions, we have chosen and displayed data from different studies. We used the database UM-NIK to find 1,805 research papers and other material. After removing the duplicates, we were left with 1,758 studies. In the first step of our review, we used the criteria for inclusion and exclusion, and marked the disciplines that are relevant for our research. Then we reviewed the titles and abstracts, after which we were left with 329 relevant works. After a further review we removed 306 irrelevant studies. The second step of the review contained a more detailed study of the remaining literature. We read 23 studies, from which we chose only the most relevant. We were left with 5 studies, which we analysed in greater detail and implemented in the results of our research.

---

## 4 Conclusion

When social media were created, they were a new tool to communicate, but, at the same time, they were tools with which we can analyse the success of their use, for example, how many people a post on Instagram has reached, etc. [15]. The key difference that the authors keep mentioning is the two-way communication, feedback from the consumers that is created through comments, private messages, likes, shares, etc. The authors also researched the use of social media networks for efficient B2B strategies in such a way that, next to the descriptive method, they also researched 145 B2B companies that work in different areas. They discovered that, after the creation of social media networks, B2B companies struggled to adapt to them, and it took a long time for them to do so. The cause of this lay in them being used to one-way communication. Two-way communication leads to long term and solid relationships, for example, with the help of posts and comments that have a deeper emotional meaning.[15]. The key in the success of B2B companies is the use of social media networks, as this is necessary for the adaptation to an information society where the consumers are located. Fraccastoro and others [16] conducted a study because of the changes in business of small and medium sized B2B companies that were caused by social media networks and tools for digital communication. They wanted to find out how these companies used these tools and how their use effects the sale process of the companies. They concluded that the direct internet access to large amounts of data and knowing customers and their preferences enables the companies to create target groups. The analysed companies that use social media lowered their costs by about 40-60%. In the study they concluded that the burdens of geographic boundaries is greatly reduced by the use of social media and other digital tools [16]. During the study they defined 3 main phases of the selling and communication process on social media networks of small and medium sized companies, which are: Recognising new business opportunities, persuasion and relationship management. All three phases are tied together in a conceptualised selling process that moves from the integration of potential customers, changing of the needs and wishes of existing customers, construction of transactional and strategic methods to business relations with customers. Cartwright and others [17] have carried out a study in which they concluded that the use of social media networks with the purpose of B2B communication is a new and rapidly growing trend. They pointed out three key areas that B2B companies can access using social media networks: Tools for increasing sales, integrated communication and the integration of employees. All three areas are interconnected, which means that their successful operation depends on constant cooperation and coordination [17]. Magar [6] defines business to business or inter-enterprise cooperation as » a situation, where one company enters into a market transaction with another company, for example, between a producer and a wholesaler«. B2B companies, therefore, do not conduct sales with single transactions, such as, for example, the purchase of a t-shirt; instead, they build high value relationships, and therefore have higher prices and conduct more complex and long term sales; they educate their customers, and, through that, become a source of their funds [18]. Social media play a vital role in the successful business conduct and customer contact creation for B2B companies. They offer these companies an environment where they

can communicate with their customers and guarantee good business, no matter the time and geographic boundaries. Different social media platforms are used to reach different groups of people. When choosing a social media platform B2B companies need to pay attention to which target audience uses which platform [15]. If the companies want to be successful with their social media network communication, they need to pay attention to the feedback that they receive. We think that our study serves as an addition to the understanding of the role and significance of B2B companies and their role in the scope of social media. Our contribution can be seen mainly in the information concerning the changes in B2B communication with the development of the Internet and social media, in the influence of social media on the way and success of B2B communication, and the influence of social media use frequency on the success of B2B communication. We think that we have answered all our research questions. A deeper study of the specific strategies of successful companies and their adaptation to the changes that the creation of social media has brought, would require further research with the help of interviews or questionnaires of a large number of successful and unsuccessful companies.

## References

- [1] T. Cawsey and J. Rowley, “Social media brand building strategies in B2B companies”, *Marketing Intelligence & Planning*, 34(6), 754–776., 2016, doi:10.1108/mip-04-2015-0079.
- [2] F. Habibi, C. A. Hamilton, M. J. Valos and M. Callaghan, “E-marketing orientation and social media implementation in B2B marketing”, *European Business Review*, 27(6), 638–655, 2015, doi:10.1108/eb-03-2015-0026.
- [3] W. Wang, D. Pauleen and T. Zhang, “How social media applications affect B2B communication and improve business performance in SMEs”, *Industrial marketing management*, 54, 4-14, 2016, DOI:10.1016/j.indmarman.2015.12.004.
- [4] M. Juntunen, E. Ismagilova and E. Oikarinen, “B2B brands on Twitter: Engaging users with a varying combination of social media content objectives, strategies and tactics”, *Industrial marketing management*, 89, 630-641, 2020, <https://doi.org/10.1016/j.indmarman.2019.03.001>.
- [5] N. Buratti, F. Parola and G. Satta, “The use of social media marketing in B2B services: A look at some “conservative” industries”, *University of Verona, Department of Economics and Business Studies, Verona, Italy*, 2017, ISBN 9788890432774.
- [6] C. T. Magar, “Social Media as a Support Tool For B2B Communication (Bachelor’s Thesis)”, *Oulu University of Applied Sciences, Information Technology, Oulu, 2016*, [https://www.theseus.fi/bitstream/handle/10024/113244/Thapa\\_Chandani.pdf?sequence=1&isAllowed=y](https://www.theseus.fi/bitstream/handle/10024/113244/Thapa_Chandani.pdf?sequence=1&isAllowed=y).

- 
- [7] N. Hague, P. Hague and M. Harrison, “B2B Marketing: 10 Key Differences from Consumer Marketing”, *B2B International*, 2005, <https://www.b2binternational.com/publications/b2b-marketing/>.
- [8] A. Mansikkaoja, “The Adoption of Social Media in Design B2B”, *Department of Marketing Hanken School of Economics, Helsinki*, 2019.
- [9] B. Kavak, N. Özdemir and G. Erol-Boyacı, “A Literature Review of Social Media for Marketing: Social Media Use in B2C and B2B Contexts”, *Managing Social Media Practices in the Digital Economy*, 67-96, 2020, DOI:10.4018/978-1-7998-2185-4.ch004.
- [10] A. Marchand, T. Hennig-Thurau and J. Flemming, “Social media resources and capabilities as strategic determinants of social media performance”, *International Journal of Research in Marketing*, 38(3), 549-571, 2021, <https://doi.org/10.1016/j.ijresmar.2020.09.011>.
- [11] Y. Chawla and G. Chodak, “Social media marketing for businesses: Organic promotions of web-links on Facebook”, *Journal of Business Research*, 135, 49-65, 2021, <https://doi.org/10.1016/j.jbusres.2021.06.020>.
- [12] S. Andersson and N. Wikström, “Why and how are social media used in a B2B context, and which stakeholders are involved?”, *Journal of Business & Industrial Marketing*, 2017, DOI:10.1108/JBIM-07-2016-0148.
- [13] C. McMahan and J. Park, “Exploring Youtube Marketing Communication Among 200 Leading National Advertisers”, *Journal of Promotion Management*, 27(4), 487-502, 2020, <https://doi.org/10.1080/10496491.2020.1851845>.
- [14] H. Cripps, T. Mejtöfr and A. Kumar-Sings, “The role of Twitter in B2B knowledge Exchange and innovation”, *Innovation and enterprise*, 4, 27-45, 2016, ISBN: 978-1-85924-232-2.
- [15] J. Järvinen, A. Tollinen, H. Karjaluoto and C. Jayawardhena, “Digital and social media marketing usage in B2B industrial section”, *Marketing Management Journal*, Volume 22, Issue 2, Pages 102-117, 2012.
- [16] S. Fraccastoro, M. Gabriellsson and E. Bolman Pullins, “The integrated use of social media, digital, and traditional communication tools in the B2B sales process of international SMEs”, *International Business Review*, 30(4), 2021, <https://doi.org/10.1016/j.ibusrev.2020.101776>.
- [17] S. Cartwright, H. Liu and C. Raddats, “Strategic use of social media within business-to-business (B2B) marketing: A systematic literature review”, *Industrial Marketing Management*, 97, 35-58., 2021, <https://doi.org/10.1016/j.indmarman.2021.06.005>.
- [18] K. Bodnar and J. L. Cohen, “The B2B social media book: Become a marketing superstar by generating leads with Blogging, LinkedIn, Twitter, Facebook, Email, and more”, *John Wiley & Sons*, 2011, ISBN: 978-1-118-21430-5.





# Pain Overview: Classification, Conceptual Framework, and Assessment

Nuno M Duarte<sup>1</sup>, José A Garcia-Pedraza<sup>2</sup>, Marlene E Santos<sup>3,4</sup>

<sup>1</sup> CISA – Centro de Investigação em Saúde e Ambiente, Escola Superior de Saúde –  
Instituto Politécnico do Porto  
nsd@ess.ipp.pt

<sup>2</sup> Laboratorio de Farmacología (Departamento de Fisiología y Farmacología). Facultad de  
Farmacia. Universidad de Salamanca  
joseagp@usal.es

<sup>3</sup> CISA – Centro de Investigação em Saúde e Ambiente, Escola Superior de Saúde –  
Instituto Politécnico do Porto

<sup>4</sup> Centro de Investigação – Instituto Português de Oncologia do Porto  
mes@ess.ipp.pt

**Abstract.** *The ability to evict noxious stimulus increases the likelihood of surviving. It is the result of interactions between specialized cells, the spinal cord, and the brain. Nociceptive pain is related to direct injury of the body. Other forms of pain may not be linked to visible injury. Being multidimensional in nature, classification attempts are unable to embark the plethora of elements that constitute pain. Pain theories can explain the nociceptive quality of it while failing to explain other qualities. Efforts culminated in the development of gate control theory, which spawned many advances in pain management. Assessment tools are useful to determine the intensity of pain and its impact on quality of life. Judicious use of these scales allows healthcare professionals to properly manage patients pain and are validated instruments widely used in research. This short review aims to expand awareness about the phenomenon of pain, its mechanisms, and its measurement.*

**Keywords.** Nociception, pain classification, gate control, pain scales, brief pain inventory

## 1 Introduction

Throughout history, humans had to deal with pain and its consequences. Our understanding of the mechanisms of pain allowed us to improve its management in a variety of contexts. Despite of this, pain is still considered “...*the oldest medical problem and the universal physical affliction of mankind...*”, has Marcia Meldrum highlights in her article “*A capsule history of pain management*” [1].

According to the International Association for the Study of Pain (IASP) the revised definition of pain is “An unpleasant sensory and emotional experience associated with, or resembling that associated with, actual or potential tissue damage.”[2].It is noteworthy that there wasn't always a consensus regarding pain definition. The revised definition, although with limitations, has become globally accepted by non-governmental organizations, including the World Health Organization (WHO), health care professionals, researchers in the pain field and governments [2]. To recognize what pain is, what causes it, how it is perceived and detected by the body, several studies were carried out over more than a century. A brief description of the anatomy and physiology of pain is presented below.

## 2 Anatomy and physiology description

### 2.1 Nociceptors

Nociceptors are specialized neurons which are peripherally localized and respond to a noxious stimulus. According to their action potential, conduction velocity and morphology, nociceptors can be classified in A-beta ( $A\beta$ ), A-delta ( $A\delta$ ) and C-fibers.  $A\delta$ -fibers are myelinated and can conduct pain signals at velocities of 5-30m/s.[3], [4].  $A\beta$ -fibers are quicker (30-70m/s) but not exclusively nociceptors since they enervate skeletal muscle (muscle contraction) and are mechanoreceptors, not always responding to noxious stimulus. C-fibers are unmyelinated, smaller in diameter and slower than the previous ones (0,5-2,0m/s), constituting most of the nociceptors [3]. A-fibers respond to mechanical and thermal (mainly heat but also cold) insults. C-fibers are polymodal in nature and respond to mechanical, thermal (mainly heat) and/or chemical insults, which displays the rich functional heterogeneity of these nociceptors and their role in monitoring tissue conditions. A-fibers respond to mechanical and thermal (mainly heat but also cold) insults. C-fibers are polymodal in nature and respond to mechanical, thermal (mainly heat) and/or chemical insults, which displays the rich functional heterogeneity of these nociceptors and their role in monitoring tissue conditions [4].

Nociceptors project distally to the skin, where they end in the proximity of Keratinocytes, Mast cells and Langerhans cells. Furthermore, they also project centrally to the central nervous system, past the dorsal root ganglia and the trigeminal ganglion to synapse with second order neurons or interneurons of the spinal cord or the trigeminal subnucleus caudalis respectively, one of the three subnuclei of the spinal trigeminal nucleus [4]. After entering the

spinal cord through the dorsal horn, C-fibers mostly, but also some A-fibers, ascend vertically along the Lissauer tract until they synapse in the Rexed laminae. C-fibers (slower, diffuse pain) synapse mostly in lamina II and some in lamina I with interneurons, while A-fibers (fast, well localized pain) synapse preferably in lamina V directly with second order neurons, despite axons of these fibers crossing the lamina II, allowing for crosstalk between the two pain pathways [4]. Second order neurons ascend through the spinal cord in several tracts, after decussating, carrying the pain signal to the thalamus. Modulation is accomplished by nucleus in the spinal cord [3].

### 3 Classification of pain

When considering a classification scheme for pain the primary guide should always be that it must have clinical relevance. Healthcare professionals should be able to apply the classification(s) effectively so that the experienced pain can be tackled with the best evidence-based approach, thus improving the patient's quality of life [5]. Also, when classifying patient's pain, healthcare professionals must be aware that these classifications may overlap.

The traditional way of classifying pain is using the temporal factor which can be either "acute" or "chronic". Acute pain (sometimes called "good pain") is considered nociceptive since it relates to the activation of nociceptors when tissue injury occurs. It serves the purpose of alerting the body of tissue injury [6]. Some examples of acute pain are the post-operative pain, trauma and acute back pain [7]. Usually, acute pain subsides after a few months when tissue heals, albeit if not properly managed in some situations can lead to persistent (chronic) pain. Chronic pain is considered persistent or intermittent pain for a long period of time, which is most often arbitrarily set at 3 to 6 months. The chronification of pain is not well understood, however it is suggested that central and peripheral sensitization along with genetic predisposition and psychological factors may be responsible for it [5], [6].

Pain is also anatomically classified which is very useful for physicians. When the specific region of the body where pain is perceived is identified it allows for rapid action [5].

Etiological classification of pain is predicated on the underlying condition causing the pain. It is often divided in malignant and non-malignant causes to distinguish between cancerous and non-cancerous pain even though there is no reason to believe that the mechanisms responsible for cancerous pain are different from the non-cancerous pain [5].

The pathophysiological classification is one of the most useful classifications since it compiles the mechanistic and pathological causes as well as anatomical location. Pain can then be categorized in nociceptive and neuropathic pain. Nociceptive pain can be further divided into somatic and visceral pain. Somatic pain refers to injuries of the skin, muscle, and bone, while visceral pain refers to internal organ tissues which is felt indirectly [5], [6]. Similarly, neuropathic pain can be attributed to injury, although in this case it's the peripheral or the central nervous system that is damaged. Because of these injuries to nervous tissue, abnormal neural activity takes place, resulting in tingling, numbness, shooting pain

and other somatosensory perceptions. Examples of neuropathic pain are diabetic neuropathy and phantom limb pain [5].

## 4 Models of pain

In a groundbreaking paper by *Ronald Melzack* and *Patrick D. Wall* in 1965, the gate control theory was postulated. This theory was a milestone, given that reconciled concepts from the two dominant theories at the time, the specificity theory, and the pattern theory, both corroborated by physiological data although seemingly incompatible. A discussion of the notions brought forth by these theories is essential to better understand our current knowledge related to the processes of pain.

**Specificity theory**, postulated by *Max Von Frey*, in 1894 put forth the existence of specialized fibers responsible for pain signaling. The theory relied on two major concepts, 1) the body exhibits specialized structures which only respond to a kind of stimuli and 2) these specialized structures have a direct connection to the brain. Thanks to *Von Frey* four somatosensory modalities were defined: cold, heat, pain, and touch [8]. All the other skin senses were derived from these four senses. The theory, albeit very intuitive and relatable, especially considering current knowledge about pain pathways, had a main shortcoming. *Melzack* elegantly explains why the second concept of the theory (the direct line between specialized nerve fibers in the skin and the brain) is not a physiological fact but a psychological assumption which is not in accordance with clinical, and psychological evidence. Indeed, when considering pain from an amputated limb (phantom limb pain), causalgia (burning pain originating from lesion of peripheral nerves) or neuralgias (resulting from partial or full damage of fibers from infections or degenerative diseases) the concept of a direct connection from the periphery to the brain doesn't hold up [9]. Furthermore, non-noxious stimuli can also elicit pain (allodynia), or it may occur without a stimulus in some situations. All of these conditions argue against the existence of a direct connection, from the periphery to the brain [9].

The psychological assumption made by specificity theory was put into question by other pain models. Generally, the so called “**pattern theories**” are based on the concept of a summation effect by *Goldscheider*. An initial proponent of specificity theory, *Goldscheider* later postulated that repeated sub threshold stimulation could cause pain and that these inputs converged and summate centrally in the grey matter of the spinal cord [8]. From this concept emerged *Nafe's* proposal that all fiber endings are similar and consequently the sensation of pain is produced by a specific firing pattern, while its intensity and other qualities are connected to the spatial and temporal profiles of excitation of these nonspecific receptors. This model completely ignored observations of specialized nerve endings and others supporting specificity theory [8].

In 1965 a new model of pain was proposed that unified specificity theory concepts and pattern theory central summation and modulation [8]. The **gate control theory** recognizes the physiological evidence of touch fibers and nociceptors stating that these peripheral

afferents transmit their signal to discrete structures in the spinal cord. The signal is relayed to three hubs, according to the model, 1) the substantia gelatinosa (SG), 2) the dorsal column and 3) a group of cells they called the transmission cells (T cells). Signals reaching these hubs are modulated, primarily in substantia gelatinosa which functions as the main “gate”. In the dorsal column system, afferent patterns function as a central control trigger, meaning they activate selective brain processes that influence the modulation of the gate control system. Furthermore, the T cells relay information to the so called “action system” responsible for pain perception and behavior. As shown in Fig. 1, large A-fibers and small C-fibers activate T cells while SG projections, inhibit the signal produced by the afferent fibers. In turn, A fibers increases activity of SG inhibitory effect (negative feedback) and C-fibers decrease activity of SG (positive feedback).

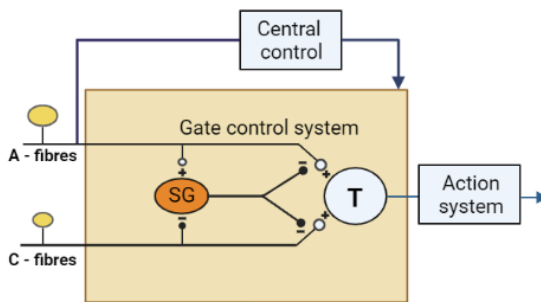

**Figure 1.** Depiction of the gate (SG) and its interactions with different fibers and cells. The gate is opened when C-fiber stimulation prevails over the inhibitory effect of A-fibers. The central control (descending pathways) modulates the signal.

When a stimulus is applied to the skin, A-fibers and C-fibers may be activated, and, depending on the intensity and type of stimulus, the produced signal may be relayed by one or the two type of fibers in different patterns. It is implied that C-fibers and others small fibers are “tonically” active and adapt slowly, holding the gate in a relative opened position. A-fibers only fire when a stimulus is applied [9]. A-fibers adapt more quickly than their smaller counterparts, resulting in further opening of the gate, unless there is some event that overcomes the rapid adaptation of these fibers like rubbing or scratching the skin. When this happens, A-fibers signaling prevails, closing the gate and preventing summation of the small fibers signal. If the signals arriving at the SG and T cells reach a threshold the gate opens, and ascending pathways are triggered which result in the experience of pain [9]. Gate control theory spawned remarkable research in the field of pain. Many of the discoveries regarding the anatomy and physiology of somatosensory systems, made since its postulation is remarkably consistent with the theory, however the model is not without its flaws. For example gate control theory is unable to explain in detail how does the inhibition of small C-fibers occurs by the large A-fibers [10].

## 5 Pain Assessment

The attempt to “quantify” pain is always a challenging task. The different qualities of pain, along with its personal and subjective traits makes it difficult and maybe impossible to develop a common metric from which we can measure and compare the described pain experiences.

Instruments for acute pain are very practical and focus primarily on one quality of pain which is intensity. They are **unidimensional pain scales**. Conversely, when assessing chronic pain which is much more insidious, complex and may cause or be caused by other confounding factors, instruments rely on qualitative aspects of pain and its impact on daily function capability. In this case **multidimensional pain scales** are necessary to give an in-depth comprehensive picture of the patient’s pain experience [7], [11].

Unidimensional scales are very sensitive in determining the intensity of pain by patient’s and are systematically used in post-operative and trauma scenarios. It should be kept in mind that these instruments depend on patient’s willingness and capability of reporting their pain, consequently they cannot be used in patients with cognitive impairment, dementia or with which physicians cannot communicate [7], [11]. There are 3 main scales for pain intensity that are validated and can be used. They are the Numeric Rating Scale (NRS) the Visual Analogue Scale (VAS) and the Verbal Rating Scale (VRS). The NRS is simple and easy to understand, doesn’t require dexterity, paper, or pen, unlike VAS, and can be applied in telephone interviews. It consists of an 11-point integer scale where zero is no pain and 10 the worst pain ever felt [11]. VAS consists of a 100-mm horizontal line in which the left-hand end represents no pain (=0) and the right-hand end represents the worst pain imaginable (=100). The patient is asked to mark a point on the line [7]. Finally, the VRS is a categorical scale of intensity where the patient is given four words (none; mild; moderate; severe) to describe the pain. Given that VAS produces a continuous variable it seems logical that the power to detect meaningful variations in pain intensity would be attained with this scale. As discussed in a review paper by *Marianne Jensen Hjermstad et al.* that compared these different scales in pain assessment, it is said about VAS that “*This scale potentially offers the greatest opportunities for discrimination, although in practice this is illusory if most respondents are unable to discriminate PI with precision beyond nine or 10 distinct levels.*” being PI the abbreviation for “pain intensity” [12]. In fact, this reflects the preference for the more widespread scale used, the NRS which along with the VAS as shown better discriminatory power of intensity of pain when compared to VRS.

Considering chronic pain, the use of validated multidimensional scales is useful enough to guide and evaluate pharmacological treatment and intervention therapies. This is not to say that these instruments can embrace the full spectrum of sensations and experiences of chronic pain. Indeed, chronic pain includes not only the obvious sensory dimension, but also physiological, psychological, and environmental dimensions, which combined cannot be fully measured by any assessment tool. There are two main multidimensional assessment tools, the Brief Pain Inventory (BPI) and the McGill Pain Questionnaire (MPQ), with the following common features: They are qualitative in nature, comprehensive (focusing on description of

the pain) and measure physical functioning [7]. The BPI is validated for many of the chronic pain syndromes and widely use in clinical practice. It consists of a 17-item rating scale. A body outline is presented so that the patient can shade the body part(s) where pain occurs. Several NRS scales are also used to determine intensity of pain in the last 24 hours and another NRS scale is used to determine pain interference in several domains of activities and daily functions (i.e.: mood; general activity; walking ability; sleep) [13]. The MPQ contains 20 subgroups of list words used to describe sensory (sub-group 1-10), affective (sub-group 11-15), evaluative (sub-group 16), and miscellaneous (sub-group 17-20), components of pain [13]. Each word as a different score and the use of this instrument gives two indexes, the pain rating index (PRI) and present pain index (PPI). PRI is the sum of ranked scores and PPI is determined on a 6-point (0-5) NRS scale. Used in different settings and translated to various languages, the MPQ is largely used in research on acute and chronic pain demonstrating high reliability and validity [13]. A brief mention to another scale, the 36 -Item Short Form Survey (SF-36) is noteworthy. This questionnaire, albeit not specific for pain, can be useful in pain contexts. Extensively used in research and a wide range of illnesses, it gives a standardized measure of the quality of life (QOL) of individuals and populations [14].

## References

- [1] M. L. Meldrum, "A Capsule History of Pain Management," *J. Am. Med. Assoc.*, vol. 290, no. 18, pp. 2470–2475, 2003.
- [2] S. N. Raja *et al.*, "The revised International Association for the Study of Pain definition of pain: concepts, challenges, and compromises," *Pain*, vol. 161, no. 9, 2020.
- [3] S. Bourne, A. G. Machado, and S. J. Nagel, "Basic Anatomy and Physiology of Pain Pathways," 2014.
- [4] A. E. Dubin and A. Patapoutian, "Review series Nociceptors : the sensors of the pain pathway," vol. 120, no. 11, 2010.
- [5] P. M. Orr, B. C. Shank, and A. C. Black, "The Role of Pain Classification Systems in Pain Management," *Critical Care Nursing Clinics of North America*, vol. 29, no. 4. Elsevier Inc, pp. 407–418, 2017.
- [6] J. Woessner, M. Holistic, and P. Care, "Overview of Pain : Classification and Concepts," no. October, 2018.
- [7] J. Collins, "Oxford Handbook of Pain Management," *Anaesthesia*, vol. 67, no. 3, pp. 341–341, 2012.
- [8] M. Moayedid and K. D. Davis, "Theories of pain : from specificity to gate control," no. Rey 1995, pp. 5–12, 2012.

- [9] R. Melzack and D. P. Wall, "Pain mechanisms: A new theory," vol. 150, no. 3699, pp. 971–979, 1965.
- [10] P. W. Nathan and P. Rudge, "Testing the gate-control theory of pain in man," *J. Neurol. Neurosurg. Psychiatry*, vol. 37, no. 12, pp. 1366–1372, Dec. 1974.
- [11] H. Breivik *et al.*, "Assessment of pain," *Br. J. Anaesth.*, vol. 101, no. 1, pp. 17–24, 2008.
- [12] M. J. Hjerstad *et al.*, "Studies Comparing Numerical Rating Scales , Verbal Rating Scales , and Visual Analogue Scales for Assessment of Pain Intensity in Adults: A Systematic Literature Review," *J. Pain Symptom Manage.*, vol. 41, no. 6, pp. 1073–1093, 2011.
- [13] T. Bendinger and N. Plunkett, "Measurement in pain medicine," *BJA Educ.*, vol. 16, no. 9, pp. 310–315, 2016.
- [14] Physiopedia contributors, "36-Item Short Form Survey (SF-36)," *Physiopedia*. [Online]. Available: [https://www.physio-pedia.com/index.php?title=36-Item\\_Short\\_Form\\_Survey\\_\(SF-36\)&oldid=239687](https://www.physio-pedia.com/index.php?title=36-Item_Short_Form_Survey_(SF-36)&oldid=239687). [Accessed: 18-Feb-2022].



# Tablet Splitting: Influence of Technique and Tablet Format

Ana Alexandre<sup>1</sup>, Sónia Ferreira<sup>2</sup>, Ângelo Jesus<sup>3</sup>

<sup>1</sup> Escola Superior de Saúde (ESS) – Instituto Politécnico do Porto (IPP), Porto, Portugal  
anacbaalexandre@gmail.com

<sup>2</sup> Serviços, Farmacêuticos, Centro Hospitalar Universitário de São João, Porto, Portugal  
sonia.ferreira@chs.j.min-saude.pt

<sup>3</sup> Centro de Investigação em Saúde e Ambiente (CISA) – Escola Superior de Saúde (ESS) –  
Instituto Politécnico do Porto (IPP)  
acj@ess.ipp.pt

**Abstract.** *Tablet splitting is a commonly used technique to obtain half of the dose or to facilitate tablet intake. However, there is a risk of not obtaining the correct dose and the efficacy depends on factors such as splitting method and tablet characteristics. Objective: To assess significant differences regarding tablet format or splitting method, regarding loss of mass and splitting accuracy. Methods: Volunteers split ten formulations by hand or using a kitchen knife. Results were treated in order to verify compliance with European Pharmacopeia standards for tablet splitting and recommendations on loss of mass. SPSS was used to assess significant differences between the two methods and tablet format when analysing loss of mass or splitting accuracy. Results: Of the twenty formulation/method combinations, only five complied with all the criteria. There was a significant difference regarding methods and loss of mass, with splitting by hand being the one to achieve the best results. Oblong tablets scored significantly better regarding loss of mass and splitting accuracy. Conclusion: Results seem to indicate that best results can be achieved when splitting tablets if using oblong tablets and splitting them by hand.*

**Keywords.** Drug compounding/methods, tablets, tablet splitting, tablet characteristics, tablet format

## 1 Introduction

Tablet splitting consists in subdividing a tablet in order to facilitate its intake or to provide smaller doses, although its efficacy depends on many factors, such as tablet shape, size, splitting technique/device and patient ability (motor skills and visual accuracy being the most discussed)[1], [2]. This technique is commonly used in households, and is estimated to reach one third of the prescriptions[3]. The main advantages of using this technique are the ease of swallowing a smaller fraction of the tablet, cost reduction and dose flexibility, especially in pediatrics and geriatrics. Whereas the problems associated with this technique are mainly due to the lack of ability to obtain equal parts after breaking the tablet, either due to physical characteristics or the patient's ability to do so [4], and the loss of mass due to crumbles [5], [6]. It has also been reported that some tablets are difficult to break, especially if they are of smaller size [7]. Altogether, it has been concluded that in some populations the negative experiences with splitting tablets may reach 36% of the prescriptions, leading to poor compliance of the medication regimen[7]. The problem with unequal parts can be overlooked if the splitting occurs to facilitate the intake, but might be a major issue if the main goal is to obtain smaller doses. If the tablets break into several pieces when split, it may be impossible to use the tablet altogether or it may lead to the rejection of the broken pieces, which will increase the costs for the patient [3], [7]. Unequal splitting may increase the variability of the concentration-time profile, which may be important in narrow therapeutics drugs [8], may reduce total exposure with the compound over time because of the loss of substance and has been shown to result in unintended change or failure of drug response in 3% of the patients [3]. Regarding the splitting technique, the most common seem to be breaking tablets by hand, using a knife or a tablet splitter [5]. In order to assess the best method, there have been many studies conducted so far. The results are mixed, but seem to indicate that it may be preferable to split tablets by hand or using a kitchen knife [9]. However, many of these studies have been studying best case scenarios where the person who breaks the tablets is a trained pharmacy professional (normally a pharmacy technician, or a pharmacist) and the formulations are known to be easily breakable [10]. As for tablet characteristics, it has been postulated that oblong tablets split better than round ones, as well as thinner ones [4], [11]. The presence of coating and a score line provides lower variation of the obtained portions, especially if it is a deep one [12], [13]. However, modified or extended-release tablets must not be split even if they present all the characteristics previously mentioned, since splitting will compromise the release of the product, making it available faster than it was intended to [14]. There are some proposed measures in order to improve the tablet splitability. Some are regarding the tablet, recommending that the industry chooses to manufacture tablets that are easily breakable and guarantee less loss of mass and similar halves [15]. Others believe that information should be the first step, which seems to be relevant considering only 12% of patients indicate that they have been given instructions in order to accurately subdivide tablets [5]. In order to regulate the issue, the European Pharmacopeia created a monograph for accuracy of subdivision of tablets. The guidelines advise that in order to assess the accuracy of subdivision one must randomly select 30 tablets, break them and then discard

one half. The other half must be weighted and from the 30 halves only one can be outside the range of 85-115% of the theoretical mass and none can be outside the range 75-125% [16]. It has also been proposed that the loss of mass should not be greater than 3% [16].

The objectives of this study are to assess if there are any significant differences when untrained volunteers split previously selected scored tablets, by analysing the results regarding tablet format, splitting method, loss of mass and the probability of obtaining accurate halves.

## 2 Methodology

Formulations identified by a team of pharmacy technicians as being often split in hospital practice were gathered. For this study, formulations that were scored, had not expired and had at least 60 tablets available were considered to integrate it. Thirteen formulations were initially listed, however one of them expired before the trial began, one of them was not commercialized in Portugal and the other one had tablets from two different batches. The ten remaining formulations are described in Table 1.

**Table 1.** Studied formulations

Code	Formulation	Active substance	Format
A	Decadron® 0,5 mg	Dexamethasone	Round
B	Carvedilol GP® 6,25 mg	Carvedilol	Round
C	Lorazepam Cinfa 2,5 mg	Lorazepam	Round
D	Zyloric 100 mg	Allopurinol	Round
E	Tegretol® CR 400mg	Carbamazepine	Round
F	Risperidona Basi 3 mg	Risperidone	Oblong
G	Amlodipina GP® 5 mg	Amlodipine	Oblong
H	Hidantina® 100	Phenytoin	Round
I	ADT 25 mg	Amitriptyline	Round

A total of sixty tablets were randomly chosen from each formulation and were weighted using a Kern Abs 220-4 analytical scale. Half of the tablets (n=30) were then split by hand and the other half was cut using a kitchen knife. The volunteers who split the tablets had no previous experience with splitting and were given no instructions on how to do it. Each half was then weighted individually on the same scale and the results were recorded considering that the half on the right of the operator was half number one (H1) and the other one was half number two (H2). When there were crumbles instead of halves, the authors chose the two biggest portions in order to make the required measurements. The records for each formulation were then inserted in a Microsoft® Excel 2010 spreadsheet, totalling 90 results per formulation/method combination. The software was then used to verify which tablets complied with the specifications from the European Pharmacopeia for splitting tablets and which did not have a loss of mass greater than 3%. As for splitting accuracy, only the results

from H1 were used, since the European Pharmacopeia calls for only one half of each tablet to be weighted. For the loss of mass test, a sum of the weights of both halves was used. In order to assess if there were any significant differences between methods and tablet format, SPSS v22.0 was used in order to perform chi-square tests to assess if there were statistically significant associations between the method and format and the amount of equally subdivided tablets or loss of mass.

## 3 Results

### 3.1 Splitting Accuracy

Regarding splitting accuracy, eight of the twenty formulation/method combinations passed the European Pharmacopeia criteria (Table 2). Three of those had been split with a kitchen knife and five had been split by hand.

**Table 2.** Accuracy of Splitting and Loss of Mass

Code	Method	Outside the 85%-115% range	Loss of mass $\geq 3\%$	Passed all tests
<b>A</b>	Knife	12	9	X
	By hand	19	29	X
<b>B</b>	Knife	20	30	X
	By hand	17	0	X
<b>C</b>	Knife	16	24	X
	By hand	10	0	X
<b>D</b>	Knife	1	1	X
	By hand	0	0	✓
<b>E</b>	Knife	0	0	✓
	By hand	0	0	✓
<b>F</b>	Knife	2	1	X
	By hand	0	0	✓
<b>G</b>	Knife	5	18	X
	By hand	0	0	✓
<b>H</b>	Knife	1	2	X
	By hand	1	0	✓
<b>I</b>	Knife	2	1	X
	By hand	2	1	X
<b>J</b>	Knife	12	7	X
	By hand	8	1	X

### 3.2 Loss of Mass

Twelve of the twenty formulation/method combinations presented at least one tablet with a loss of mass greater than 3%. In one particular case, all of the 30 tablets tested had a loss of mass greater than 30% and another one had 29 tablets with that characteristic (Table 2).

### 3.3 Approved Formulations

Of the twenty formulation/method combinations, only six complied with all the criteria established (Table 2). Five of them had been split by hand and only one had been split using a kitchen knife. When considering formulations, only one out of the ten (formulation E) complied with all the criteria when using both methods for splitting.

### 3.4 Chi-Square test

When applying chi-square tests to assess if there was any significant relation between method or tablet format and loss of mass or splitting accuracy, the p-values obtained were as listed on Table 3.

**Table 2.** Chi-square results

Variables	p-value
Format / Mass uniformity	0.000
Format / Loss of mass	0.000
Method / Mass uniformity	0.163
Method / Loss of mass	0.000

## 4 Discussion

When a tablet is presented with a scoring line, it is easy to assume that it is prepared to be subdivided, especially because it is of the utmost importance for the patient to achieve the required doses in order for the treatment to be successful. However, the findings of this study indicate that many scored tablets fail to pass the European Pharmacopeia tests and have unacceptable mass losses. These findings are similar to those achieved by other authors. Hill et al. [17] evaluated drug content and weight uniformity for six medications, with warfarin being the one showing the highest number of half tablets falling out of the proxy specification range. Riet-Nales et al. [9] studied the best methods for tablet subdivision. Although studying only one formulation, the experiment showed that tablet splitters and kitchen knife may not accurately subdivide tablets in equal parts. Cook et al. [18] also evaluated one single formulation of cyclobenzaprine, concluding that tablet fractioning could result in unpredictable dosing and therapeutic response. Finally, Carvalho et al. [19] studied three formulations commonly split in a hospital context, with all of them exceeding the Pharmacopeia limits regarding loss of mass. However, these studies tried to evaluate splitting in a context of best-case scenario, which does not accurately describe the day-to-day

experience by untrained users, since usually volunteers are pharmacy practitioners and the pills used are known to split easily [10]. Focusing on studies which tried to describe user experience we can highlight two. One by El-Baseir et al [20], where untrained users were asked to split five cardiovascular formulations. Results in this study showed a wide weight variability that could be clinically significant when using three different methods (scissors, splitting by hand and a tablet splitter device). The other experiment was by Peek et al. [1] and studied tablet splitting by thirty older men, obtaining results indicating that variation in doses ranged from 9 to 37% from those intended. In the present study, regarding splitting accuracy, only eight formulations achieved the expected results and there seems to be no relation between method and accuracy. However, when considering tablet format, the p-value obtained was 0.000, which means there is an association between format and splitting accuracy, as previously stated by other authors[4], [11], [21]. As for loss of mass, the case seems to be different, as cutting the tablets with a knife seems to produce significantly greater loss of mass when compared with splitting by hand. According to the tests performed, the p-value obtained was 0.000, which means there is a significant relation between method and loss of mass. This is of great importance, because one of the main reasons presented to promote tablet splitting seems to be cost reduction for the patient. However, if the patient fails to produce two halves of the tablets, the cost reduction will be nonexistent and therefore will no longer justify the process. Besides the cost reduction, loss of mass was in some cases so large that it may compromise the treatment efficacy itself. There was also a significant relation between tablet format and loss of mass. These results were to be expected when consulting the literature but should not be verified as they can interfere with treatment and treatment adherence. It is especially serious in the case of tablets which present scored lines, which often lead the patient to think that it is prepared to be split. As these results cannot be extrapolated to similar tablets, these tests should be performed by an independent authority in order to establish which tablets are prepared to be subdivided and provide for the patient to be given those when in need of lower doses. It should also be stated on the brochure if the scored line is optimized for tablet splitting to achieve half of the dose or just to facilitate tablet intake. When counseling patient in the pharmacy, pharmacy professionals should advise the patient in order to improve their experience with the treatment. This includes splitting tablets and the health professional should always verify if the patient is used to the technique and which results they have achieved with it. When the patient is not fully enlightened, the pharmacy professional should explain the available options and advise the patient to split tablets by hand and, only when it is not possible to do so, to split them using any other method, including using a kitchen knife. Regarding tablet format, results indicate that patients who choose oblong tablets will encounter less episodes of significant loss of mass. This study did not evaluate drug content, so it is not possible to assess if the obtained halves could provide the therapeutic levels needed for the treatment to work. It also only evaluated two splitting methods, leaving behind other less popular ones, but which are also applied by patients. Given the many factors which contribute to the accuracy of splitting, it is not possible to extrapolate these findings to similar formulations.

## 5 Conclusion

Having a scoring line does not assure that it is advisable to split the tablet, since it may lead to unequal halves and/or significant loss of mass. This fact is of great clinical importance if the person splits the tablet in order to obtain half of the tablet dose. The results obtained indicate that choosing an oblong tablet and breaking it by hand are to be considered when in need of tablet splitting. The Pharmacy Technician should take this into account when counselling the patient so that he or she will obtain accurate halves and the loss of mass is not significant.

## References

- [1] B. T. Peek, A. Al-Achi, and S. J. Coombs, "Accuracy of tablet splitting by elderly patients.," *JAMA*, vol. 288, no. 4, pp. 451–2, Accessed: Feb. 28, 2019. [Online]. Available: <http://www.ncbi.nlm.nih.gov/pubmed/12132974>
- [2] M.-M. G. Wilson, F. E. Kaiser, and J. E. Morley, "Tablet-Breaking Ability of Older Persons With Type 2 Diabetes Mellitus," *The Diabetes Educator*, vol. 27, no. 4, pp. 530–540, Jul. 2001, doi: 10.1177/014572170102700408.
- [3] R. Quinzler, C. Gasse, A. Schneider, P. Kaufmann-Kolle, J. Szecsenyi, and W. E. Haefeli, "The frequency of inappropriate tablet splitting in primary care," *European Journal of Clinical Pharmacology*, vol. 62, no. 12, pp. 1065–1073, Nov. 2006, doi: 10.1007/s00228-006-0202-3.
- [4] E. van Santen, D. M. Barends, and H. W. Frijlink, "Breaking of scored tablets: a review.," *European journal of pharmaceutics and biopharmaceutics : official journal of Arbeitsgemeinschaft fur Pharmazeutische Verfahrenstechnik e.V*, vol. 53, no. 2, pp. 139–45, Mar. 2002, Accessed: Feb. 28, 2019. [Online]. Available: <http://www.ncbi.nlm.nih.gov/pubmed/11879995>
- [5] B. E. A. Ekedahl, "Patients' Experiences of Splitting Tablets," *Clinical Medicine Research*, vol. 2, no. 4, p. 58, 2013, doi: 10.11648/J.CMR.20130204.14.
- [6] N. Rodenhuis, P. A. G. M. de Smet, and D. M. Barends, "The rationale of scored tablets as dosage form," *Eur J Pharm Sci*, vol. 21, no. 2–3, pp. 305–308, 2004, doi: 10.1016/J.EJPS.2003.10.018.
- [7] N. Rodenhuis, P. A. G. M. de Smet, and D. M. Barends, "Patient experiences with the performance of tablet score lines needed for dosing," *Pharm World Sci*, vol. 25, no. 4, pp. 173–176, Aug. 2003, doi: 10.1023/A:1024852529628.





- 
- [8] L. M. Tahaineh and S. F. Gharaibeh, "Tablet splitting and weight uniformity of half-tablets of 4 medications in pharmacy practice," *J Pharm Pract*, vol. 25, no. 4, pp. 471–476, 2012, doi: 10.1177/0897190012442716.
- [9] D. A. van Riet-Nales *et al.*, "The accuracy, precision and sustainability of different techniques for tablet subdivision: breaking by hand and the use of tablet splitters or a kitchen knife," *Int J Pharm*, vol. 466, no. 1–2, pp. 44–51, May 2014, doi: 10.1016/J.IJPHARM.2014.02.031.
- [10] J. K. Eserian and M. Lombardo, "Tablet subdivision: far beyond the splitting technique," *Int J Pharm*, vol. 476, no. 1–2, p. 77, Dec. 2014, doi: 10.1016/J.IJPHARM.2014.09.046.
- [11] K. C. van der Steen, H. W. Frijlink, C. M. A. Schipper, and D. M. Barends, "Prediction of the ease of subdivision of scored tablets from their physical parameters," *AAPS PharmSciTech*, vol. 11, no. 1, pp. 126–132, Mar. 2010, doi: 10.1208/S12249-009-9365-4.
- [12] J. Noviasky, V. Lo, and D. D. Luft, "Which medications can be split without compromising efficacy and safety?," *Journal of Family Practice*, vol. 55, no. 8, pp. 707–708, 2006.
- [13] Y. Pramar, V. das Gupta, and C. Bethea, "Stability of captopril in some aqueous systems," *Journal of Clinical Pharmacy and Therapeutics*, vol. 17, no. 3, pp. 185–189, Jun. 1992, Accessed: Mar. 23, 2011. [Online]. Available: <http://www.ncbi.nlm.nih.gov/pubmed/1639881>
- [14] J. Martinho, M. Guerreiro, and A. Simón, "O fraccionamento de comprimidos no ambulatório: implicações para a prática clínica," *Revista Portuguesa de Farmacoterapia*, vol. 2, pp. 119–125, 2010.
- [15] U.S. Department of Health and Human Services Food and Drug Administration and Center for Drug Evaluation and Research, "Guidance for Industry Tablet Scoring: Nomenclature, Labeling, and Data for Evaluation Guidance for Industry Tablet Scoring: Nomenclature, Labeling, and Data for Evaluation Contains Nonbinding Recommendations," 2013. Accessed: Apr. 11, 2022. [Online]. Available: <http://www.fda.gov/Drugs/GuidanceComplianceRegulatoryInformation/Guidances/default.htm>
- [16] A. N. Zaid, A. A. Ghoush, R. Al-Ramahi, and M. Are'r, "Evaluation of the Discrepancy between the European Pharmacopoeia Test and an Adopted United States Pharmacopoeia Test Regarding the Weight Uniformity of Scored Tablet Halves: Is Harmonization Required?," *PDA J Pharm Sci Technol*, vol. 66, no. 1, pp. 20–27, Jan. 2012, doi: 10.5731/PDAJPST.2012.00791.



- 
- [17] S. W. Hill, A. S. Varker, K. Karlage, and P. B. Myrdal, "Analysis of drug content and weight uniformity for half-tablets of 6 commonly split medications," *J Manag Care Pharm*, vol. 15, no. 3, pp. 253–261, 2009, doi: 10.18553/JMCP.2009.15.3.253.
- [18] T. J. Cook, S. Edwards, C. Gyemah, M. Shah, I. Shah, and T. Fox, "Variability in tablet fragment weights when splitting unscored cyclobenzaprine 10 mg tablets," *J Am Pharm Assoc (2003)*, vol. 44, no. 5, pp. 583–586, 2004, doi: 10.1331/1544-3191.44.5.583.COOK.
- [19] A. Carvalho, S. Ferreira, Â. Jesus, C. Deveza, J. Gonçalves, and P. H. Carinha, "Study of mass uniformity during tablet splitting in three different drugs," 2012.
- [20] M. El-Baseir and H. E. L. Bsir, "Evaluation of split tablets of cardiovascular medicines," *International Journal of Pharmacy Practice*, vol. 20, no. Supplement\_2, pp. 31–101, Sep. 2012, doi: 10.1111/J.2042-7174.2012.00235.X.
- [21] M. Sedrati, P. Arnaud, J. E. Fontan, and F. Brion, "Splitting tablets in half," *American Journal of Hospital Pharmacy*, vol. 51, no. 4, pp. 548–549, Feb. 1994, doi: 10.1093/AJHP/51.4.548.



# Use of the Smartphone Camera to Monitor Adherence to Inhaled Therapy

Sofia Ferraz<sup>1</sup>, Rute Almeida<sup>2</sup>, Pedro Vieira-Marques<sup>2</sup>, Nuno Escudeiro<sup>3</sup>

<sup>1</sup> INESC TEC - Institute for Systems and Computer Engineering, Technology and Science, Porto, Portugal  
sofia.a.ferraz@inesctec.pt

<sup>2</sup> CINTESIS - Center for Health Technology and Services Research, Faculty of Medicine, University of Porto, Porto, Portugal  
{rutealmeida, pmarques}@med.up.pt

<sup>3</sup> Department of Computer Science, Polytechnic of Porto - School of Engineering, Porto, Portugal  
nfe@isep.ipp.pt

**Abstract.** *Adherence to inhaled controller medications is crucial for patients with chronic respiratory illnesses to achieve favorable clinical outcomes. Self-management measures have been shown to enhance health outcomes, decrease unnecessary interventions, and improve disease control. However, compliance evaluations have difficulties in establishing a high level of trustworthiness, as patient's self-reported high compliance rates are frequently regarded unreliable. A mobile application module to objectively verify inhalation usage using image snapshots of the inhalation counter and optic character recognition has shown to be promising, but insufficient for some inhaler models. In this paper a model specific approach was explored to enable reliable adherence measurement. To achieve this, a machine learning model was trained on an inhaler image dataset. The trained model had an average accuracy of 88% in recognizing the digits on the dose counter of an inhaler model. These results show the potential to gain additional evidence for inhaler compliance.*

**Keywords.** medication adherence, mHealth, remote monitoring, optical character recognition, inhaled therapy

## 1 Introduction

Asthma affects about 300 million people globally and accounts for 1 in every 250 deaths. In Europe alone, approximately 30 million people have asthma and 15,000 people die yearly from this disease [1]. Although asthma exacerbations occurrences can be reduced with appropriate regular therapy and patient education, treatment adherence is generally low among patients with asthma. As a matter of fact, some studies show that adherence is less than 50% in children and as low as 30% in adults [2]. This low adherence may be due in part to misinformation or confusion regarding complicated treatment regimens. Poor medication adherence is concerning, since it is known to increase risk of asthma exacerbations, leading to higher mortality, greater financial burden for the patient and health system, as well as decreased quality of life [2]. Numerous adherence-improvement interventions have been introduced, but most have been only moderately successful with little evidence of long-term sustainability or reduction of health care utilization and cost [3].

Mobile Health (mHealth) technologies can improve disease outcomes and may be an especially powerful tool to deliver effective behavioral health interventions that are dynamic, user-centric, and continuously adapted [4]. Medication-use monitoring can provide important information for patients, researchers, and health professionals, with the aim of facilitating improved adherence and of improving treatment prescribing. Patient self-report and clinician assessments of medication adherence are notoriously unreliable [5].

Regarding inhaled medication, current mHealth applications require the user to manually enter the readings from the dose counters of these medical devices. This process is slow and prone to error. As the internet becomes more embedded into medical monitors through Wi-Fi and Bluetooth technologies, more sophisticated systems transmit the values from the connected devices to the smartphone. However, this adds costs to the manufacturing of the device and brings connectivity issues [6]. People who cannot afford to upgrade to these expensive devices will fail to receive the benefits [7].

In the United States, smartphones are owned and regularly carried by approximately 50% of 12–17 year-olds and 75% of adults ages 30–49 [5]. The advantages of smartphones over other devices is not only the fact that they are affordable, but also that they are very powerful, with most models nowadays integrating several cores in their main processor. They are also standalone devices with a camera, a battery, and audio output and an Internet connection [10]. Therefore, these devices show high potential to be explored as a relevant mHealth tool.

## 2 Methods

Optical character recognition (OCR) is a tool that converts scanned images of typewritten or hand-written text into machine-readable text [8]. Despite recent technology advancements, the available OCR approaches still present several limitations (e.g. the dependency on the quality of input images), and are still not able to compete with human reading capabilities with desired accuracy levels [7][9].

Previous research [10] used a mobile application module to objectively verify inhalation

usage through image snapshots of the inhaler counter and OCR. Although this research demonstrated encouraging results in the use of OCR to address non-adherence to inhaled medicine, the results indicate that the approach used is less effective for particular inhaler models (e.g. *Seretaide* and *Twisthaler*). As such, we hope to build on prior work by developing a machine learning algorithm trained on an image database of the *Seretaide* model and optimize the OCR performance for this specific inhaler. To accomplish the proposed objectives, annotated and pre-processed images of *Seretaide* inhaler devices were used to train and validate a machine learning model.

**Dataset.** The database consists of 354 images of the *Seretaide* inhaler model in PNG format, with dimensions of 640 x 360 pixels, collected under ideal conditions using a LG-V700 (Android) camera app. These images show a wide representation of digits in the dose counter; additionally, the background varies between black, white, and multi-color, and the lighting source of the photo varies between natural light and artificial light. For the purpose of training a machine learning model on inhaler pictures, a manual annotation process was performed on all images present in the dataset. This task was accomplished with the help of the VGG Image Annotator (VIA) tool [11].

With the aid of this software, it was possible to collect annotations regarding the position and dimensions of the dose counter and the corresponding digits that appear on the display.

**Image Pre-Processing.** All images suffered four pre-processing steps: rotating, cropping, convert to grayscale and resizing. The images in the dataset were rotated 90° right, since the photos were acquired horizontally, and cropped according to the dimensions of the dose counter indicated on the annotations file. Since the cropping measurements were not consistent across the dataset, the cropped-out images did not have the same size; hence, all images were resized to standardize the data.

**Model Architecture.** With an OCR approach in mind, a neural network (NN) consisting of convolutional layers (CNN) to extract a sequence of features and recurrent layers (RNN) to propagate information through this sequence, was developed. Additionally, it instantiates a new “endpoint layer” for implementing CTC loss. The former enables using unsegmented pairs of images and corresponding text transcriptions to train the model without any character/frame-level alignment [12]. More specifically, the architecture of the NN consists of an input layer, two convolutional layers each followed by a pooling layer, two bidirectional layers, a CTC layer and finally an output layer (Figure 1).

**Model Training.** In later stages, a training and validation dataset were generated. For this purpose, the dataset was shuffled randomly, so that each time the dataset is split a new training and validation dataset are created. Additionally, the dataset split into 90 % training set (318 images) and 10% validation set (36 images). This project runs using the Google Colab environment and the network was built using TensorFlow 2. 6.. The model was trained in 200 epochs and a batch size of 5.

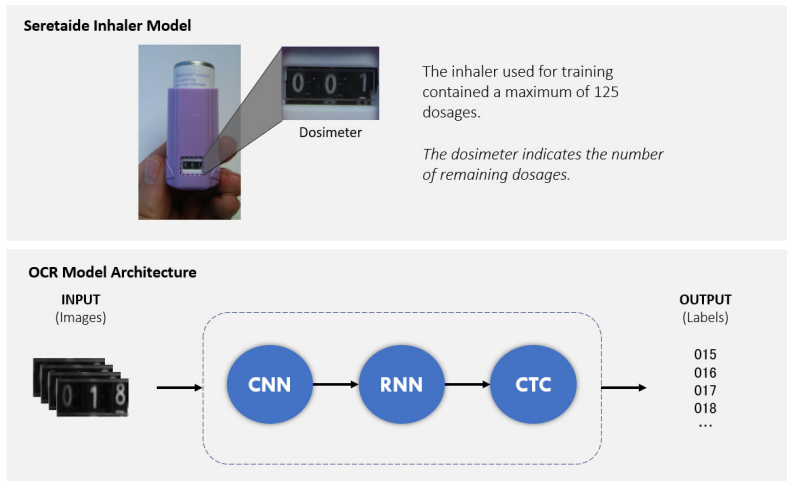

**Figure 1.** Information regarding the inhaler used in the dataset, along side a photo of a *Seretaide* inhaler (above); Schematics of the optical character recognition model's architecture (bellow).

### 3 Results

To evaluate the model, several metrics were taken into consideration. The findings of this examination are summarized in Table 1, which includes the average values for the metric following five tests, as well as the standard deviation.

**Table 1.** Evaluation Metrics for the Trained Model.

Metrics	Average (%)	Standard Deviation
Accuracy	87,2	0,04
Exact Match Ratio	87,2	0,04
Hamming Loss	0,13	0,04
Recall	88,3	0,06
Precision	87,2	0,04
F1-measure	87,1	0,04

### 4 Discussion

The exact match ratio can be considered a challenging metric since it doesn't support the notion of being partially correct.

As it can be seen in Table 1, the exact match ratio is 87,2%, which indicates that a large part of the predicted results were entirely correct, and consequently reflects a good model performance.

The Hamming Loss considers the incorrect label predictions and the relevant labels not predicted, over the total number of labels. In this case, the computed hamming loss is

0,13 %, which is a significantly low value and indicates a good performance of the learning algorithm.

For this model, the calculated recall was 88,3 % (Table 1), which indicates that a large number of the actual labels were predicted. On the other hand, precision is the ratio of how much of the predicted is correct, i.e., it only considers the positive predicted results. In this case, the precision equals the exact match ratio (87,2 %).

Furthermore, the F1 measure is the harmonic mean of Precision and Recall and gives a better measure of the incorrectly classified cases than the Accuracy Metric. The F1 measure reaches 87,1%, which is an indication of both good precision and good recall.

The purpose of this effort was to enhance the *Seretaide* model's OCR performance. In comparison to prior study, the model's accuracy has increased significantly (from 38% to 87%). It is important to highlight, however, that the datasets utilized to evaluate these methodologies are not equal, and hence a direct comparison cannot be drawn. Nevertheless, the advancements in this research might be seen as an indication of significant improvement.

## 5 Conclusions and Future Work

The purpose of this paper was to develop a text recognizer for an inhaler model (*Seretaide*). This was done by building a machine learning model, trained on a database of inhaler images, compatible with mobile applications.

To the best of our knowledge, there are not many approaches in the literature that help to reduce the unreliability of patient compliance and self-reporting by making use of OCR to record effective dosage in inhaler dose counters. Furthermore, the proposed work explores the potential of a customized OCR approach to enhance the performance of already existing algorithms, thus making this work relevant to help mitigating the patient's unreliable, self-reported adherence.

Nevertheless, further improvements are still needed to enhance the detection performance. It will be critical in future work to compare the findings of this model to those of the general model in the previous research, on the same collection of photos (independent of the image set used to train the model). Additionally, this model could be applied to additional inhaler models in order to assess the impact of employing customized machine learning models on other inhalers, thus, determining if performance is maintained. Furthermore, an object detector-like algorithm can be implemented to detect the dose counter, thus avoiding the cropping stage in the image pre-processing.

## Acknowledgments

This research was part of the project “mINSPIRE—mHealth to measure and improve adherence to medication in chronic obstructive respiratory diseases - generalization and evaluation of gamification, peer support and advanced image processing technologies”, POCI-01-0145-FEDER-029130, supported by the ERDF (European Regional Development Fund), COMPETE2020 (Programa Operacional Competitividade e Internacionalização), Portugal

2020 and by Portuguese Funds through FCT (Fundação para a Ciência e a Tecnologia).

We thank PaCeIT for providing the *Seretaide* image dataset, without which this work would not have been feasible.

## References

- [1] J. E. Fergeson, S. S. Patel, and R. F. Lockey, “Acute asthma, prognosis, and treatment,” *Journal of Allergy and Clinical Immunology*, vol. 139, no. 2, pp. 438–447, 2017, ISSN: 10976825. DOI: 10.1016/j.jaci.2016.06.054. [Online]. Available: <http://dx.doi.org/10.1016/j.jaci.2016.06.054>.
- [2] R. Jeminiwa, L. Hohmann, J. Qian, K. Garza, R. Hansen, and B. I. Fox, “Impact of eHealth on medication adherence among patients with asthma: A systematic review and meta-analysis,” *Respiratory Medicine*, vol. 149, no. February, pp. 59–68, 2019, ISSN: 15323064. DOI: 10.1016/j.rmed.2019.02.011. [Online]. Available: <https://doi.org/10.1016/j.rmed.2019.02.011>.
- [3] B. G. Bender, “Technology Interventions for Nonadherence: New Approaches to an Old Problem,” *Journal of Allergy and Clinical Immunology: In Practice*, vol. 6, no. 3, pp. 794–800, 2018, ISSN: 22132198. DOI: 10.1016/j.jaip.2017.10.029. [Online]. Available: <https://doi.org/10.1016/j.jaip.2017.10.029>.
- [4] D. A. Fedele, A. McConville, J. Graham Thomas, *et al.*, “Applying Interactive Mobile health to Asthma Care in Teens (AIM2ACT): Development and design of a randomized controlled trial,” *Contemporary Clinical Trials*, vol. 64, no. March, pp. 230–237, 2018, ISSN: 15592030. DOI: 10.1016/j.cct.2017.09.007. [Online]. Available: <http://dx.doi.org/10.1016/j.cct.2017.09.007>.
- [5] A. H. Y. Chan, H. K. Reddel, A. Apter, M. Eakin, K. Riekert, and J. M. Foster, “Adherence Monitoring and E-Health: How Clinicians and Researchers Can Use Technology to Promote Inhaler Adherence for Asthma,” *Journal of Allergy and Clinical Immunology: In Practice*, vol. 1, no. 5, pp. 446–454, 2013, ISSN: 22132198. DOI: 10.1016/j.jaip.2013.06.015. [Online]. Available: <http://dx.doi.org/10.1016/j.jaip.2013.06.015>.
- [6] E. Finnegan, M. Villarroel, C. Velardo, and L. Tarassenko, “Automated method for detecting and reading seven-segment digits from images of blood glucose metres and blood pressure monitors,” *Journal of Medical Engineering and Technology*, vol. 43, no. 6, pp. 341–355, 2019, ISSN: 1464522X. DOI: 10.1080/03091902.2019.1673844. [Online]. Available: <https://doi.org/10.1080/03091902.2019.1673844>.
- [7] D. Tsiktsiris, K. Kechagias, M. Dasygenis, and P. Angelidis, “Accelerated Seven Segment Optical Character Recognition Algorithm,” *5th Panhellenic Conference on Electronics and Telecommunications, PACET 2019*, pp. 1–5, 2019. DOI: 10.1109/PACET48583.2019.8956283.



- 
- [8] K. Kanagarathinam and K. Sekar, "Text detection and recognition in raw image dataset of seven segment digital energy meter display," *Energy Reports*, vol. 5, pp. 842–852, 2019, ISSN: 23524847. DOI: 10.1016/j.egy.2019.07.004.
- [9] A. Chaudhuri, K. Mandaviya, P. Badelia, and S. K. Ghosh, *Optical character recognition systems*. 2017, vol. 352, pp. 9–41, ISBN: 9783319502526. DOI: 10.1007/978-3-319-50252-6\_2.
- [10] P. Vieira-Marques, R. Almeida, J. F. Teixeira, *et al.*, "InspirerMundi-Remote Monitoring of Inhaled Medication Adherence through Objective Verification Based on Combined Image Processing Techniques," *Methods of Information in Medicine*, 2021, ISSN: 2511705X. DOI: 10.1055/s-0041-1726277.
- [11] A. Dutta and A. Zisserman, "The VIA annotation software for images, audio and video," in *Proceedings of the 27th ACM International Conference on Multimedia*, ser. MM '19, Nice, France: ACM, 2019, ISBN: 978-1-4503-6889-6/19/10. DOI: 10.1145/3343031.3350535. [Online]. Available: <https://doi.org/10.1145/3343031.3350535>.
- [12] M. Yousef, K. F. Hussain, and U. S. Mohammed, "Accurate, data-efficient, unconstrained text recognition with convolutional neural networks," *Pattern Recognition*, vol. 108, p. 107482, Dec. 2020, ISSN: 00313203. DOI: 10.1016/j.patcog.2020.107482. arXiv: 1812.11894.



## Short Reports



# A 2-Tap Indirect ToF CMOS Image Sensor for Multi-Frequency Demodulation

Peyman F. Shahandashti<sup>1</sup>, P. López<sup>1</sup>, V.M. Brea<sup>1</sup>, D. García-Lesta<sup>1</sup>,  
Miguel Heredia-Conde<sup>2</sup>

<sup>1</sup> Centro Singular de Investigación en Tecnoloxías Intelixentes (CiTIUS), Universidade de Santiago de Compostela, Spain  
{peyman.fayyaz, p.lopez}@usc.es

<sup>2</sup> Center for Sensor Systems (ZESS), University of Siegen, Germany  
heredia@zess.uni-siegen.de

**Abstract.** *Indirect time of flight (IToF) allows for accurately retrieving 3D geometry without needing exorbitant time resolution. Nevertheless, the use of continuous-wave (CW) periodic modulation brings the need for multiple frequency measurements to solve depth ambiguities or cope with multi-path interference. Sequential acquisition of multiple frames reduces the frame rate, while harmonic distortion of the modulation waveforms produces wiggling in the depth estimation. This work presents the operation of an IToF CMOS image sensor designed to provide single-shot multi-frequency measurements. A macro-pixel structure allows acquiring multi-frame data in one shot, while resonant demodulation annihilates the harmonic content. The novel architecture consists of  $10\ \mu\text{m} \times 10\ \mu\text{m}$  2-tap pixels with a 20% fill factor (FF). Post-layout simulations show promising 3D reconstruction for up to 16 different simultaneous frequencies.*

**Keywords.** CMOS image sensor, time-of-flight, macro-pixel, single-shot, multi-path

## 1 Introduction

IToF measures the phase difference between the emitted and the received signal, providing high spatial resolution and straightforward processing compared to the other 3D measurement techniques. IToF works based on modulated continuous or pulsed light in concurrence with the electrooptical demodulation of a photo-mixing device (lock-in pixels). Unlike 2D imaging, in IToF, the integration process is controlled by applying predefined signals to the modulation gates. Therefore, depth calculations are based on samples of the cross-correlation of the received signal and the applied control signal. In this way, the range data of each pixel can be retrieved from a group of measurements [1].

Despite many advantages IToF offers, it has some critical challenges like motion artifacts, background light error, and ambiguous range. One of the other essential issues in IToF systems is Multi-Path-Interface (MPI), meaning that each pixel may receive more than a single bounce, resulting in a superposition of sinusoidal signals reaching the pixel. MPI errors usually increase the measured distance value since the direct path (desired bounce) distance is shorter than the indirect path (undesired bounce).

Typically, the solution for this problem is to increase the number of measurements with different modulating frequencies sequentially, but the resulting increase in the total exposure time decreases the frame rate of depth images. Besides, the required number of frequencies will increase linearly with the number of received bounces. Using the measurements obtained at different frequencies, the distance values for individual bounces can be obtained in a closed form [2]. Here, we demonstrate the successful realization of a single-shot multi-frequency IToF architecture in 180 nm CMOS technology using a resonant demodulation concept.

## 2 Multi-frequency ToF measuring concept

The use of macro-pixels allows for single-shot multi-frequency demodulation [3], thus enabling multiple-path depth imaging at high frame rates. A macro-pixel can be formed by grouping numbers of pixels modulated with different frequencies, so-called *subpixels*. In this work, we focus on the case of CW sinusoidal modulation, in which a sinusoidal wave of IR light illuminates the scene at the defined frequency, and the reflected light received by the ToF pixels will generate charges that are accumulated according to the demodulation control signals of the taps. The prevalent 2-tap structure is used in our pixel's circuit.

For illustration, Fig. 1 shows a single macro-pixel consisting of an array of 4 by 4 subpixels. Each subpixel has a 2-tap structure, where both taps demodulate with the same frequency with a  $180^\circ$  phase shift. We denote as  $f(i)_{0,1}$  the frequency of the demodulating control signal at subpixel  $i$ , with  $i = 1, \dots, 16$  in this case, for both Tap0 and Tap1. For the sake of clarity, the control signals of the 4 subpixels marked with a red square in Fig. 1 are shown on the right. As can be seen, differently from conventional IToF, the demodulating frequencies are different for each pixel. Each of the 16 subpixels can be either connected to the same frequency (conventional IToF) or to 16 separate frequencies. The entire pixel array, including several macro-pixels, can be formed by repeating this pattern.

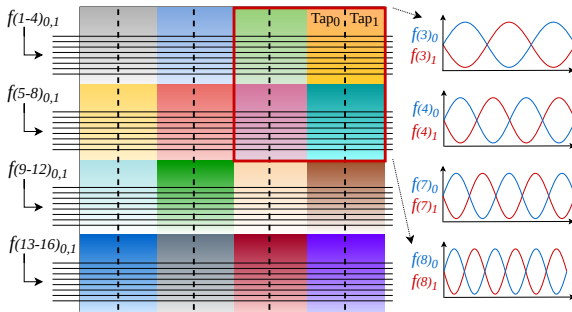

Figure 1. An array of sub-pixels with 16 possible frequencies forming a single macro-pixel.

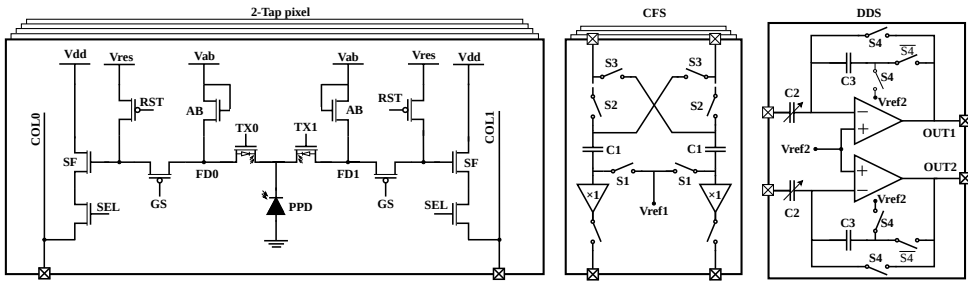

Figure 2. Schematic of the designed pixel and the readout circuitry.

### 3 Circuit description

Fig. 2 depicts the circuit schematic of the pixel and the following readout circuitry. The design includes a symmetrical structure with a pinned photodiode (PPD) as a photosensitive part, reset, global shutter, source follower (SF), and row select [4] transistors. For the source follower, reset, and row select transistors, proper sizes were selected to optimize signal swing, noise, and image delays. The analog supply voltage (Vdd) is 3.3 V for the pixel for a higher signal dynamic range.

After the exposure time, the following stages are the Column Filter Stage (CFS) and Double-Delta-Sampling (DDS) blocks. The CFS block can process and filter pixel signals. It consists of two decoupling capacitors followed by voltage followers whose outputs can be selected by a column decoder to be sent sequentially through the DDS output stage [5].

### 4 Chip Architecture

The active pixel sensor, presented in Section 3 operates in reset, integration, and read-out stages to retrieve the 3D data. Fig. 3 shows the layout design of the entire ToF range imaging system, which consists of an array of pixels, the modulation control signal tree, the biasing circuitry, the row, and column decoders, the CFS, and the DDS stage. The system has an array-shared modulation signal generator, row and column control circuits, driver

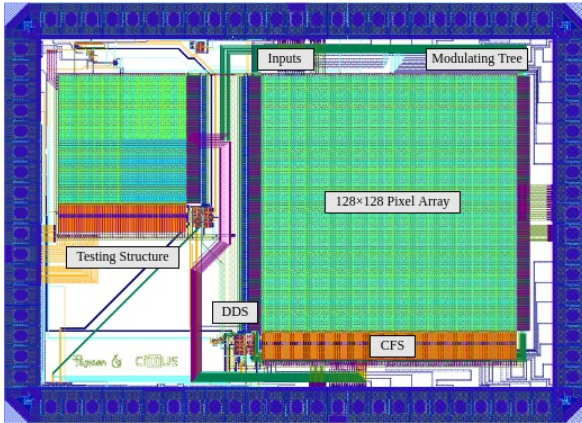

**Figure 3.** Chip design of the single-shot multi-frequency ITof system with its parts labeled.

circuits, and bias circuits for in-pixel operational amplifiers.

In previous work, we presented a resonant demodulation circuit that uses an off-chip inductance connected across the taps to achieve minimal harmonic distortion [6]. The capability of this system for generating resonant frequencies for modulating the subpixels will be studied experimentally in our future work. However, the simulation results for proving this concept were favorable.

## 5 Conclusion

This work presents the ITof pixels with readout circuitry. The proposed macro-pixel-based architecture allows for realizing the idea of single-shot multi-frequency demodulation. Furthermore, perfect sinusoidal control signals at the demodulation gates, arising from a resonant construction, enable native harmonic cancellation per pixel or group of pixels. Resonant demodulation can further reduce the average drive current of pixels, resulting in considerable power-saving and paving the way for low-powered 3D imaging systems. The next step is to prepare an experimental setup and test the proposed system.

## Acknowledgments

This project has received funding from the European Union’s Horizon 2020 research and innovation programme under the Marie Skłodowska-Curie grant agreement No 860370. This work was also funded by Spanish Ministry of Science, Innovation and Universities under grant RTI2018-097088-B-C32, from Xunta de Galicia-Consellería de Cultura, Educación e Ordenación Universitaria Accreditation 2019-2022 ED431G-2019/04 and Reference Competitive Group Accreditation 2021-2024 ED431C2021/048, co-funded by (ERDF/FEDER programme).



---

## References

- [1] M. Heredia Conde, *Compressive sensing for the photonic mixer device*. Springer, 2017.
- [2] M. Heredia Conde, T. Kerstein, B. Buxbaum, and O. Loffeld, “Fast multipath estimation for PMD sensors,” in *5th International Workshop on Compressed Sensing Theory and its Applications to Radar, Sonar, and Remote Sensing (CoSeRa 2018)*, 2018.
- [3] M. Heredia Conde, K. Kagawa, T. Kokado, S. Kawahito, and O. Loffeld, “Single-Shot Real-Time Multiple-Path Time-of-Flight Depth Imaging for Multi-Aperture and Macro-Pixel Sensors,” in *2020 IEEE International Conference on Acoustics, Speech and Signal Processing (ICASSP)*, 2020, pp. 1469–1473.
- [4] D. Stoppa and et al., “A Range Image Sensor Based on 10- $\mu$ m Lock-In Pixels in 0.18- $\mu$ m CMOS Imaging Technology,” *IEEE Journal of Solid-State Circuits*, vol. 46, no. 1, 2010.
- [5] P. F. Shahandashti and et al, “A 2-Tap Macro-Pixel-Based Indirect ToF CMOS Image Sensor for Multi-Frequency Demodulation,” in *2022 IEEE International Symposium on Circuits and Systems (ISCAS)*, IEEE, 2022, pp. 1–5.
- [6] P. F. Shahandashti, P. Lopez, V. Brea, D. Garcia-Lesta, and M. Heredia Conde, “Proposal of a Single-Shot Multi-Frame Multi-Frequency CMOS ToF Sensor,” in *2021 28th IEEE International Conference on Electronics, Circuits and Systems (ICECS)*, 2021.



# Adaptive Model Predictive Control with Regularized Finite Impulse Response Models

Christopher Illg<sup>1</sup>, Oliver Nelles<sup>1</sup>

<sup>1</sup> Research Group Automatic Control - Mechatronics,  
University of Siegen, 57076 Siegen, Germany  
{christopher.illg,oliver.nelles}@uni-siegen.de

**Abstract.** *The use of regularized finite impulse response models allows to incorporate prior knowledge of the process. This can be used to decrease the variance error of an online parameter estimation and ensures a robust system identification. The online adapted model can be used to control time-variant or nonlinear processes. This approach is named adaptive model predictive control. The investigated method is tested on a nonlinear single tank simulation and is compared to an already established method.*

**Keywords.** adaptive MPC, regularized FIR models, system identification, leaky recursive least squares, gray-box identification

## 1 Introduction

The main task in model predictive control (MPC) is to predict the future output of the process and estimate an optimal sequence for the manipulated variable with respect to an objective function. To be able to control nonlinear processes with an MPC, a linear model which is adapted online can be used. The advantage of a linear MPC is given by a closed-form solution, which is computationally efficient and yields a global optimum.

For the internal model, a finite impulse response (FIR) model structure is chosen. FIR models belong to the class of linear time-invariant models. They are well suited for the identification of stable processes as the model class is inherently stable. Further advantages are e.g. the linearity in the parameters, the output error configuration, and the insensitivity w.r.t. a wrong model order or too small dead times. However, a main drawback of this model structure is the large number of parameters which causes a high variance error. To overcome this problem, regularization can be used by introducing an additional penalty term in the parameter estimation [1]. Thus, prior knowledge can be incorporated and the variance error is decreased.

The use of regularization in a recursive weighted least squares (RWLS) method is investigated. The leaky recursive least squares (LRLS) method enables the use of regularization without losing its effect over time [2]. The estimation of the FIR model is done online in a closed-loop adaptive model predictive control (AMPC). This method is compared to an AMPC which interpolates between offline identified FIR models. Both methods are tested on a simulation of a nonlinear single tank system [3], [4].

## 2 AMPC Algorithm

In the presented AMPC algorithm, a single FIR model is used. The parameters of this model are updated with the LRLS in each time step, in order to match the current process behavior of the controlled system.

### 2.1 FIR Models

The output of a strictly proper FIR model with offset can be calculated by a linear combination of the delayed inputs  $u(k-1), \dots, u(k-n-1)$ . Consequently, the output of the model  $\hat{y}(k)$  of order  $n$  is given by

$$\hat{y}(k) = \theta_{\text{off}} + \sum_{j=1}^n \theta_j u(k-j) = \underline{x}(k)^T \underline{\theta}, \quad (1)$$

where  $\underline{x}(k)^T = \begin{bmatrix} 1 & u(k-1) & \dots & u(k-n) \end{bmatrix}$  with  $u(k < 1) = 0$  and the  $(n+1)$ -dimensional parameter vector  $\underline{\theta} = \begin{bmatrix} \theta_{\text{off}} & \theta_1 & \dots & \theta_n \end{bmatrix}^T$ . To estimate  $\underline{\theta}$ , usually a least squares algorithm is used.

## 2.2 Online System Identification

The parameters  $\hat{\theta}(k)$  at time  $k$  can be estimated by

$$\hat{\theta}(k) = \left( \underbrace{\underline{X}(k)^T \underline{Q}(k) \underline{X}(k)}_{\underline{M}(k)} + \lambda \underline{R} \right)^{-1} \underbrace{\underline{X}(k)^T \underline{Q}(k) \underline{y}(k)}_{\underline{t}(k)}, \quad (2)$$

with the regressor matrix  $\underline{X}(k) = \begin{bmatrix} \underline{x}(1) & \underline{x}(2) & \cdots & \underline{x}(k) \end{bmatrix}^T$  and the measured output vector  $\underline{y}(k) = \begin{bmatrix} y(1) & y(2) & \cdots & y(k) \end{bmatrix}^T$ . The weighting matrix is defined by  $\underline{Q}(k) = \text{diag}(\rho^{k-1}, \rho^{k-2}, \dots, \rho^0)$  with the forgetting factor  $\rho$ . The  $(n+1 \times n+1)$ -dimensional regularization matrix  $\underline{R}$  incorporates prior knowledge of the process and the strength of it is controlled by  $\lambda$ . Here, a first order impulse response preserving (IRP) kernel with exponential weighting is used. The offset parameter  $\theta_{\text{off}}$  is unregularized. For more detail refer to [5].

The calculation of (2) can be simplified by calculating  $\underline{M}(k+1)$  and  $\underline{t}(k+1)$  recursively by

$$\begin{aligned} \underline{M}(k+1) &= \rho \underline{M}(k) + \underline{x}(k+1) \underline{x}^T(k+1), \\ \underline{t}(k+1) &= \rho \underline{t}(k) + \underline{x}(k+1) y(k+1). \end{aligned} \quad (3)$$

This approach corresponds to the LRLS algorithm [2].

## 3 Simulation Results

To investigate the proposed AMPC algorithm, a single tank system is considered. The task is to control the fill level  $h(k)$  between 0 and 10 m in a tank with a small hole as an outlet by adjusting the inflow  $u(k) = \dot{V}_{\text{in}}(k)$  of the fluid. For more information about the setup and the geometric data refer to [3]. Additionally, the fill level  $h(k)$  is disturbed with additive white Gaussian noise.

The closed-loop AMPC, with no ( $\lambda = 0$ ), medium ( $\lambda = 50$ ) and strong ( $\lambda = 10^6$ ) regularization, and an open-loop AMPC are compared. The open-loop AMPC interpolates linearly between previously learned models. These models are estimated at fill levels between 0 and 5 m (training data). For the exact configuration, refer to [3]. As reference trajectory (test data) different fill levels between 0.5 and 9.5 m are specified and held for 100 time steps each. Therefore, for the open-loop AMPC both interpolating and extrapolating behavior are investigated.

The fill level trajectories are depicted in Fig. 1. For a high value of  $\lambda$  the controller leads to overshoots. Furthermore, for  $\lambda = 0$  the model is not robust, due to high parameter variance which leads to poor control ( $400 < k < 500, k > 900$ ).

Table 1 shows the different root mean squared error (RMSE) values to compare the methods.  $\text{RMSE}_{\text{all}}$  calculates the RMSE in the interval  $0 < k < 1000$ , whereas  $\text{RMSE}_{\text{inter}}$  only the interval  $k \leq 500$  and  $\text{RMSE}_{\text{extra}}$  only  $k \geq 501$  considers. It can be seen that the RMSE of the closed-loop AMPC with  $\lambda = 50$  is nearly the same as of the open-loop AMPC.

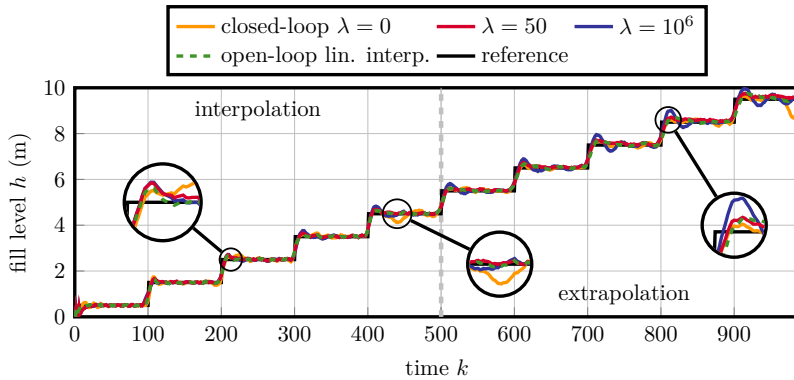

**Figure 1.** Fill level  $h(k)$  for a sequence of steps for the different AMPC methods and various regularization strengths

**Table 1.** Performance of the different AMPC methods

method	closed-loop AMPC			open-loop AMPC
	$\lambda = 0$	$\lambda = 50$	$\lambda = 10^6$	
$\text{RMSE}_{\text{all}}$	0.148	<b>0.122</b>	0.153	<b>0.121</b>
$\text{RMSE}_{\text{inter}}$	0.128	0.108	0.119	<b>0.094</b>
$\text{RMSE}_{\text{extra}}$	0.166	<b>0.135</b>	0.182	0.143

During interpolation the open-loop AMPC and during extrapolation the closed-loop AMPC is preferable.

Figure 2 shows the changing model parameters  $\hat{\theta}(k)$  over time  $k$ . For  $\lambda = 0$ , the model parameters have a high variance error and with  $\lambda = 50$  there is a good tradeoff between variance and bias error. In the approach with  $\lambda = 10^6$ , the wrong prior is weighted to highly which can be seen from the peaks of the model parameters  $\hat{\theta}(k)$ . Additionally, it shows that the the open-loop AMPC do not change its parameters during extrapolation.

## 4 Conclusion and Outlook

We describe a closed-loop AMPC using regularized linear FIR models to control a nonlinear process. It is shown that incorporating prior knowledge of the process can improve the model quality. The closed-loop AMPC performs better in the extrapolation. Whereas, if a reference trajectory in the interpolation range is given, an open-loop AMPC should be chosen.

Further research will be done on extending this concept to also perform a hyperparameter optimization online.

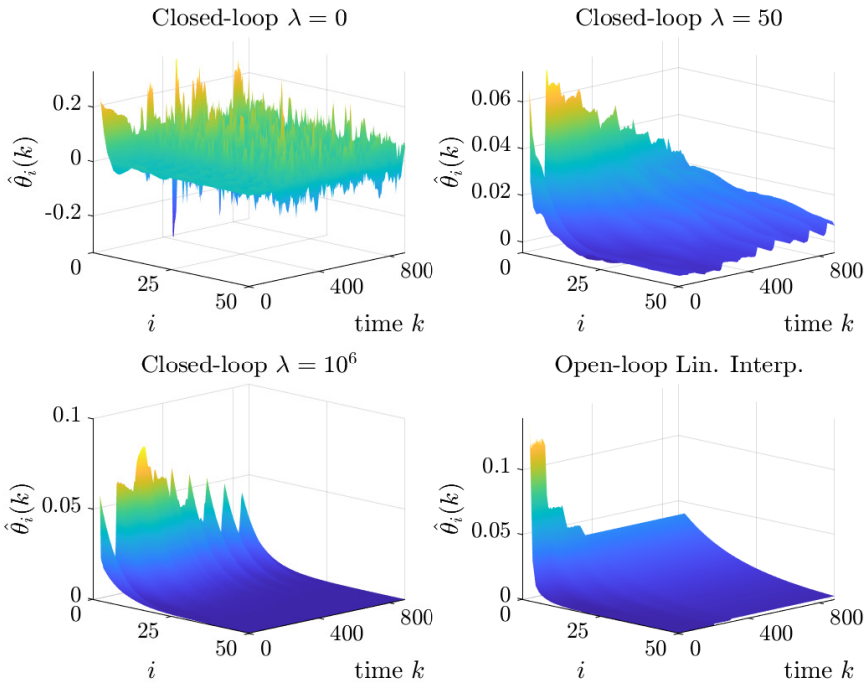

**Figure 2.** Adapted FIR coefficients during simulation of the sequence of steps for the different AMPC methods and various regularization strengths

## References

- [1] T. Münker, T. J. Peter, and O. Nelles, “Gray-box identification with regularized fir models,” *at - Automatisierungstechnik*, vol. 66, no. 9, pp. 704–713, 2018.
- [2] E. Horita, K. Sumiya, H. Urakami, and S. Mitsuishi, “A leaky rls algorithm: Its optimality and implementation,” *IEEE Transactions on Signal Processing*, vol. 52, no. 10, pp. 2924–2936, 2004.
- [3] C. Illg, T. Decker, J. Thielmann, and O. Nelles, “Adaptive model predictive control with finite impulse response models,” in *Proceedings - 31th Workshop Computational Intelligence*, 2021, pp. 149–168.
- [4] T. Kłopot and P. Skupin, “Adaptive dynamic matrix control with interpolated parameters,” in *2015 20th International Conference on Methods and Models in Automation and Robotics (MMAR)*, 2015, pp. 683–688.
- [5] T. Münker, J. Belz, and O. Nelles, “Improved incorporation of prior knowledge for regularized fir model identification,” in *2018 Annual American Control Conference (ACC)*, 2018, pp. 1090–1095.





# Introducing A Microservice-Based Mobile Software Product Line – a Technical Debt Perspective

Luka Pavlič, Tilen Hliš, Marjan Heričko, Tina Beranič

Faculty of Electrical Engineering and Computer Science, University of Maribor,  
Koroška cesta 46, Maribor, Slovenia

{luka.pavlic, tilen.hlis, marjan.hericko, tina.beranic}@um.si

**Abstract.** *The software product lines (SPL) enable development teams to fully address a systematic reuse of a shared assets to deliver a family of a similar software products. Mobile applications are an obvious and proven candidate for employing an SPL approach. Technically speaking, the SPL implementation varies. In addition to the industry-accepted best practices, including build-time directives, advanced design patterns employment, custom builds etc., the microservice architectural style (MSA) can also be used in terms of realizing SPL. Our empirical data demonstrate the impact of a SPL approach in multiple edition mobile application development. The next step in our research is to verify what the impact of the SPL implementation with MSA in the mobile application area is. Our hypothesis is, that in addition to delivering high-quality features rapidly, the positive impact on the accumulated technical debt will be demonstrated as a direct result of employing MSA to mobile development.*

**Keywords.** Software development, reuse, microservice architecture, software product lines, mobile applications, technical debt

## 1 Introduction

Reuse is one of the fundamental disciplines in software engineering. Usually, a software does not result in a single version or edition, specially tailored to certain customers. The software product lines (SPL) [2] is an approach to reuse, employed in case where a family of products shares several common functionalities [1].

The origins of microservice architecture stem from the issue of web services, which do not support all the principles of service-oriented architecture. A new phenomenon has emerged in form of microservices, which are independently developed and operated, automatically deployed reusable components, that communicate via standard protocols. Increasing attention to microservice architecture and its many advantages, emphasizing low coupling, independence of individual services, and enabled scalability, which offers systems with better performance [6]. Although this approach was not initially created to support the SPL, we see it as a perfect match.

The technical debt metaphor, rooted in the financial world, captures the amount of work that development teams owe to the product [7]. Managed carefully, it can be used as an important tool while weighting trade-offs between the high product quality and the rapid delivery of crucial functionalities carefully.

As previous research demonstrate and this paper summarize, the SPL approach has many positive implications [5]. In this paper we lay the foundation to our future research, when we will investigate the impact of the microservices-based mobile SPL. The accumulated technical debt will be investigated in detail. Our hypothesis is, that because of the microservice design, the accumulated technical debt will be more favourable.

## 2 Mobile Software Product Lines

The software product lines (SPL) proved to be an adequate solution to reuse in special cases, when several software products share a majority of functionalities, while only a fraction of functionalities are edition specific [2]. According to the original SPL idea, development efforts are directed towards developing core assets, while product development is a process of aligning core assets into final products. Authors [2] also proposes several patterns and their variants, to be used for SPL-based development.

Besides reusing technical building blocks, these also include reusing procedures and rules, associated with the software. The SPL approach brings additional costs also: architecture, building blocks and individual tests should include the possibility of variability, while business plans must be made for multiple products, not just one. However, the long term claimed contributions of SPL are as follows [2]: up to 10x improved productivity, up to 10x improved quality, joint development costs reduced by up to 60%, shortened time-to-market by up to 98% and the possibility of moving to new markets is measured in months, not in years. Authors [1] define the SPL-approach as a tool to effectively cope with variabilities. The authors address three types of variabilities [3]:

- functionality presence,
- the lack of functionality, and
- a different functionality realization.

## 2.1 Our Approach to Manage Software Product Lines

First steps in our SPL implementation included requirements gathering, designing and testing planning for the functionalities, that were collected in a multi-dimensional table. Functionalities were not only listed, but also described in terms of which edition functionality was available and if and what specialities were required for a particular functionality in a particular edition. This is how development team ended with functionalities written in several categories: common (all editions), optional (only in selected editions) and alternative (edition-specific implementation of the same functionality). Please see the Table 1 for all different editions and their difference in terms of functionalities count.

**Table 1.** Final editions compared: functionality-based differences.

<b>Edition</b>	<b>Based on</b>	<b>Base f.</b>	<b>Optional f.</b>	<b>Alternative f.</b>	<b>F. count (B+O)</b>	<b>F.diff (O+A)</b>	<b>Diff (%)</b>
Pro	Free	45	8	2	53	10	19
Free	Core	45	0	3	45	3	7
Alpha	Core	45	9	5	54	14	26
Test	Pro	53	0	1	53	1	2
Demo	Free	45	8	2	53	10	19
BB Pro	Core	45	0	3	45	3	7
BB Free	Free	45	0	3	45	3	7

Figure 2 shows available assets (components implemented as Android libraries), from which 7+1(Core Module) are fully functional Android applications. A set of functionalities is present in particular application edition by appropriate library in edition. Functionality absence is achieved by not including the library. The alternative implementation is achieved by including library and overriding (a part) of its implementation by employing appropriate design pattern. These include the use of object-oriented design, proven design patterns, extensions, and component parameterization. Design patterns [4] are used heavily, especially: factory, abstract factory, factory method, bridge, bean, adapter and others.

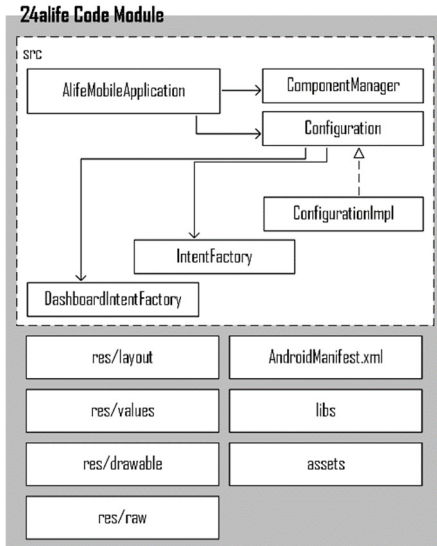
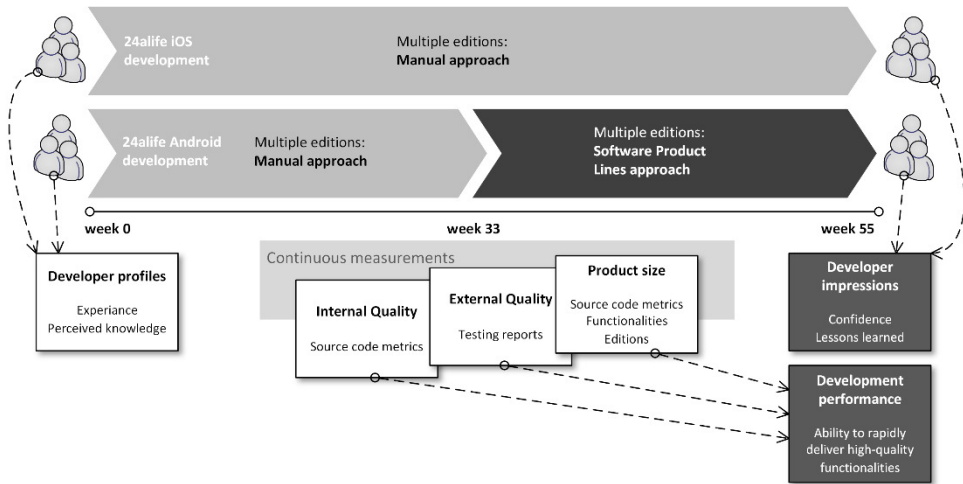

**Figure 1.** SPL architecture as a part of Core Module [5].

### 3 The Mobile Software Product Lines on Software Quality – Empirical Study Results

We will present our research outcomes, done during one year of development of mobile applications for two mobile platforms, Android and iOS, sharing a common set of functionalities [5]. Mobile applications are a part of a larger project which also included backend cloud solutions, a web portal, a media streaming server and tablet applications.

Several editions of mobile applications, applications for the Android platform, were managed with the introduction and implementation of the Software Product Line (SPL) approach, while other set of applications, applications for the iOS platform, were managed with more traditional methods of reuse, e.g. branches in version management system, sharing the same codebase, but compiling it several times, using compiler directives, runtime checking, etc. Android and iOS development teams shared the same set of functionalities that had to be developed and they were given the same time to finish the implementation. This industry-based setup gave us the opportunity to explore and share interesting pre-, mid- and post-development empirical data, compiled to research observations on SPL approach implications (see Figure 2).



**Figure 2.** Gathering research empirical data during the development process [5].

The results of the research are as follows [5]:

- The SPL approach results in 126% higher functionality-based velocity (240% higher, compared to single-edition development).
- The SPL approach enabled developers to adopt an additional 100% of new functionalities across several editions with the same effort level.
- Internal quality is not affected by introducing SPL approach.
- SPL approach enhances external quality.
- Managing several editions using non-SPL approach would reduce external quality.
- The SPL approach have a positive impact on developers' confidence in delivering new functionalities and releases frequently.

## 4 Discussion and Future Work

Our research clearly demonstrates the benefits of employing the SPL approach to enhance a reuse in a family of a similar applications. In addition to the quality improvement, it enable development teams to deliver more valuable functionalities in shorter time.

The software product lines approach can be achieved using different approaches and technical implementation. Microservices seem a natural and a promising approach to do so. Our aim of further research in the field is to verify their application to handle variabilities. We primarily want to see, if and to what extend the impact would be. In addition to improved quality and accelerated functionality delivery, we believe that the application of microservices would also enhance internal quality and, consequently, lower accumulated technical debt in the family of similar products.

## Acknowledgments

The authors acknowledge the financial support from the Slovenian Research Agency (Research Core Funding No. P2-0057).

## References

- [1] Cavalcanti YC, Machado IC, Anselmo P. 2013. Handling variability and traceability over SPL disciplines, software product line—advanced topic, Edited by Abdelrahman Osman Elfaki, Rijeka, 2013.
- [2] Clements P, Northrop L. 2001. Software product lines: practices and patterns. Boston: Addison-Wesley.
- [3] Clements PC, Bachmann F. 2005. Variability in software product lines, product line practice initiative, 2005.
- [4] Gamma E, Helm R, Johnson R, Vlissides J. Design patterns: elements of reusable object-oriented software. Boston: Addison-Wesley, 1998.
- [5] Pavlič, L, Beranič, T, Heričko, M. A product quality impacts of a mobile software product line : an empirical study. PeerJ computer science. 2021.
- [6] Lewis. J. Fowler. M. Microservices: A definition of this new architectural term. <https://martinfowler.com/articles/microservices.html> [last accessed 04/2022]
- [7] Cunningham. W. The wycash portfolio management system. in OOPSLA '92 - Experience Report, 1992.

# The Impact of Using Serious Games as a Learning Tool in Higher Education

Tina Beranič , Marjan Heričko 

Faculty of Electrical Engineering and Computer Science, University of Maribor,  
Koroška cesta 46, Maribor, Slovenia  
{tina.beranic, marjan.hericko}@um.si

**Abstract.** *In order to address current challenges in higher education, innovative teaching approaches have to be introduced. They can aid in increasing student motivation, their course involvement and engagement. At the same time, they can also boost students' learning outcomes. Our previous research studied the impact of implementing a business simulation into a study course. We explored students' knowledge acquisition and their future engagement, assessed after the introductory simulation. The study involved two demographic groups of students: IT oriented and business oriented. In both groups the use of business simulation resulted in positive outcomes, depicting the suitability of using a business simulation. Regardless of the rate of used gamification, we have to be aware of and address adequately existing challenges and risks, to avoid the negative consequences of gamification, which we define as overgamification. According to this, we identified and analysed the existing challenges and risks and proposed possible solutions used when implementing the business simulation game. Both research directions are presented in the paper, together with corresponding references and future work.*

**Keywords.** ERP systems, business simulation games, ERPsim, gamification, overgamification

## 1 Introduction

The use of innovative teaching approaches [1] is a vital topic when addressing current higher education challenges, especially when teaching digital natives. Challenges connected to students' interests, motivation and course engagement have to be addressed properly in order to achieve the highest learning outcomes. Especially appropriate and helpful are approaches that require students' active participation, such as business simulations.

Business simulations are the representatives of serious games. The history of serious games dates back to 1951 [2]. Video games, aimed at training the professionals in the military domain, were, in the 1970s, widespread to the educational domain [2]. The ancestors of serious games evolved rapidly, wherein the majority of serious games before 2002 were developed for the educational domain [2]. Serious games are one of the gamification learning methods [3]. While gamification uses just some part of the game element, serious games involve the usage of the whole gaming systems [4]. Simulations that present a most common game genre within serious games [5], [6], aid learning with virtual activities reflecting the real-world scenarios [5]. The development of business simulations goes far back, wherein the growth of simulations available on the internet can be detected since 1998 [7]. Nowadays, one of the visible representatives is ERPsim [8], a business simulation game using real-life SAP ERP, which was, in recent years, replaced by SAP S/4HANA. The business simulation, aimed at teaching ERP (enterprise resource planning) concepts, is used broadly in higher education [9]. It covers different business scenarios and simulates a real business environment. The participants use a real ERP system, and have to make business decisions based on data obtained via the collaboration between various business roles.

ERPsim has evolved constantly since its introduction [10]. It now offers four groups of simulation scenarios: Distribution, Manufacturing, Logistics and Retail Game. Each of the groups includes more scenarios with increasing complexity. The most complex and advanced scenario is the Manufacturing Advanced Game, while the Distribution Game presents the introductory simulation that includes only a few ERP functionalities, namely sales, procurement and planning processes. Many research directions are connected to business simulations. In our research, we are pursuing the topics associated with introducing and using business simulations in higher education.

In the continuation of the paper we are presenting two of our research directions. Section 2 presents the research analysing the impacts of using the business simulation as an introduction to the study course. In the continuation, Section 3 presents the research of identifying challenges and risks, and their addressing when implementing the business simulations. The paper is concluded with Section 4, offering a brief overview of our future work on the outlined research direction.

## 2 The use of a business simulation for introducing ERP concepts

ERPsim was developed with the aim to ease the understanding of complex ERP systems thematics [10], [11], representing a possible challenge regardless of students' backgrounds



and previous knowledge. With awareness of this challenge, especially when introducing ERP concepts to IT related students, we focused our previous work [12], [13] on aiding the introduction of ERP systems with the use of ERPsim business simulation.

In our paper [12] we researched the impact of using business simulation when introducing ERP concepts to IT students. The participating students have advanced IT knowledge, wherein they did not have any previous knowledge or experience with ERP systems. The business simulation was implemented as an introduction to the study course, carried out at the very first course session. After the implemented simulation, the students' opinions were gathered using a systematically defined questionnaire. We focused on gained knowledge and skills, and the impact the introductory business simulation has on students' intent for future course engagement, one of the crucial challenges in higher education. The three-year study resulted in very positive outcomes. According to the students' self-assessments, new knowledge and skills were obtained in different knowledge areas. The details are presented in Table 1. The students assessed four statements using a five-point Likert scale, 1 standing for completely disagree and 5 standing for completely agree.

**Table 1.** Obtained knowledge and skills within the three-year research [12].

Year	Average	5	4	3	2	1
<i>A simulation game contributes to the development of the technical skills necessary when using SAP ERP.</i>						
1	<b>4.1</b>	27.78%	55.56%	11.11%	5.56%	0.00%
2	<b>4.4</b>	42.86%	57.14%	0.00%	0.00%	0.00%
3	<b>4.2</b>	23.81%	76.19%	0.00%	0.00%	0.00%
<i>A simulation game demonstrates the need and benefits of integrating different ERP modules.</i>						
1	<b>4.1</b>	27.78%	55.56%	11.11%	5.56%	0.00%
2	<b>4.5</b>	50.00%	50.00%	0.00%	0.00%	0.00%
3	<b>4.2</b>	38.10%	42.86%	19.05%	0.00%	0.00%
<i>New knowledge and skills were obtained about using SAP ERP.</i>						
1	<b>4.5</b>	50.00%	50.00%	0.00%	0.00%	0.00%
2	<b>4.7</b>	71.43%	28.57%	0.00%	0.00%	0.00%
3	<b>4.3</b>	33.33%	66.67%	19.05%	0.00%	0.00%
<i>New knowledge and skills were obtained about collaboration and coordination between roles.</i>						
1	<b>4.3</b>	33.33%	66.67%	11.11%	5.56%	0.00%
2	<b>4.7</b>	71.43%	28.57%	0.00%	0.00%	0.00%
3	<b>4.4</b>	47.62%	47.62%	4.76%	0.00%	0.00%

The second part of the research [12] was studying the impact that the introductory simulation had on students' future course engagement. This was also one of the research questions in our following research [13]. In the latter, we again looked into knowledge acquisition and students' engagement, however, the population of participating students differed. While in the paper [12] we focused on IT related students, in the research [13] students participated who were obtaining business and economic degrees. The difference

lies in students' previous knowledge, while IT oriented students are more advanced in the IT domain, business oriented students are more advanced in the thematics connected to ERP systems.

Figure 1 depicts the impact of the introductory business simulation on students' future course engagement. The picture shows the students' assessment of the statement, separately for IT oriented and business oriented students. As can be seen for both groups of participants and in all of the researched years, the number of students that strongly agreed and agreed with the statements was high. Even more, within IT oriented students a great progress is seen, from 39% that agreed or strongly agreed with the statement in the first year of the business economics implementation to 67% of affirmative answers in the third year.

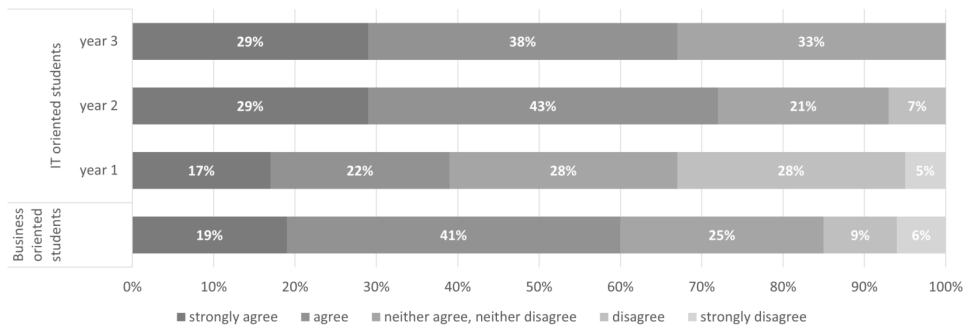

**Figure 1.** The impact of the introductory business simulation on students' future course engagement [12], [13].

In the paper [13] we also looked to see if there was a significant difference in student knowledge before and after the business simulation session. We addressed three domains: business process knowledge, technical knowledge for using SAP ERP and ERP transaction knowledge. Based on the statistical analysis, all hypotheses were confirmed, which offered further confirmation of the suitability of introductory ERPsim business simulation.

### 3 Challenges and risks within the implementation of business simulations

Although the most advanced infrastructure and tools are available and suitably refined, the introduction and use of business simulations within the educational process requires special attention. If the challenges and issues are not addressed properly, the positive effects of gamification could be nullified easily. In the paper [14] we researched what challenges and risks have to be considered when implementing gamification in higher education.

Based on the carefully implemented literature review, we identified a number of challenges and risks which we combined into three risk groups:

- Risk group 1: Game design and gamification
- Risk group 2: Introduction and application of the game

- Risk group 3: Individual differences between the participants

Together with challenges, we also proposed solutions or strategies that can be used to overcome the identified risks. The solutions were formed according to multiple years of experience with business simulations and available literature resources. An example of risk within one of the categories and the corresponding strategy to address the risk is presented in Figure 2.

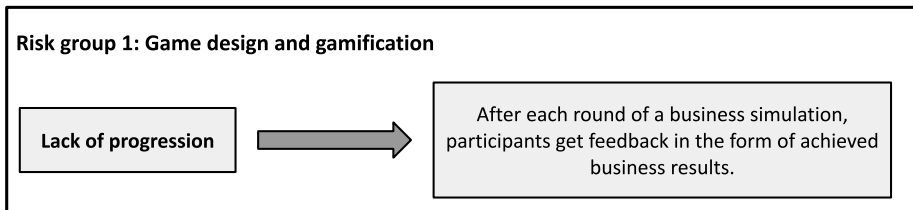

**Figure 2.** An example of identified challenge with the corresponding solution within business simulation implementation [14].

When implementing business simulation it is essential to avoid overgamification, namely, to avoid the negative consequences of gamification. In addition, to address known challenges and risks adequately, another important aspect has to be considered to maintain a high positive gamification impact. Only an appropriate rate of gamification has to be applied to truly exploit the potential of innovative approaches.

## 4 Conclusion

Serious games, especially business simulations, represent a broad research domain. Our previous research covers the domain of introducing the ERP concept to ERP newcomers and looking into challenges and their appropriate addressing in order to maintain a high contribution of gamification in higher education. The obtained results are promising, therefore, we plan to proceed actively with the outlined direction as a part of our future work. We will study in depth the overgamification challenges, using the data gathered within the business simulations implemented throughout the study semester. Our final goal is to develop and validate empirically a risk management model, assuring, together with derived guidelines, the efficient establishment and implementation of gamification elements in higher education.

## Acknowledgments

The authors acknowledge the financial support from the Slovenian Research Agency (Research Core Funding No. P2-0057). The authors would also like to thank all of the survey participants.

## References

- [1] S. Subhash and E. A. Cudney, “Gamified learning in higher education: A systematic review of the literature,” *Computers in Human Behavior*, vol. 87, pp. 192–206, 2018, ISSN: 0747-5632.
- [2] D. Djaouti, J. Alvarez, J.-P. Jessel, and O. Rampnoux, “Origins of serious games,” in *Serious Games and Edutainment Applications*, M. Ma, A. Oikonomou, and L. C. Jain, Eds. London: Springer London, 2011, pp. 25–43, ISBN: 978-1-4471-2161-9.
- [3] A. De Gloria, F. Bellotti, and R. Berta, “Serious games for education and training,” *International Journal of Serious Games*, vol. 1, Feb. 2014.
- [4] M. Sanmugam, H. Mohamed, Z. Abdullah, N. Zaid, and B. Aris, “Gamification and serious games: -the enigma and the use in education,” Nov. 2014.
- [5] E. A. Boyle, T. Hainey, T. M. Connolly, *et al.*, “An update to the systematic literature review of empirical evidence of the impacts and outcomes of computer games and serious games,” *Computers & Education*, vol. 94, pp. 178–192, 2016.
- [6] T. M. Connolly, E. A. Boyle, E. MacArthur, T. Hainey, and J. M. Boyle, “A systematic literature review of empirical evidence on computer games and serious games,” *Computers & Education*, vol. 59, no. 2, pp. 661–686, 2012.
- [7] A. Faria, D. Hutchinson, W. J. Wellington, and S. Gold, “Developments in business gaming: A review of the past 40 years,” *Simulation & Gaming*, vol. 40, no. 4, pp. 464–487, 2009.
- [8] Léger, P.-M., Robert, J., Babin, G., Pellerin, R., Wagner, B., *ERPsims*, Montréal, Qc., 2007. [Online]. Available: <https://erpsim.hec.ca>.
- [9] G. Paulet and G. Dick, “Erpsim games in management higher education,” in *Developments in Business Simulation and Experiential Learning: Proceedings of the Annual ABSEL conference*, vol. 46, 2019.
- [10] P.-M. Léger, “Using a simulation game approach to teach erp concepts,” *Journal of Information Systems Education*, vol. 17, pp. 441–447, Jul. 2006.
- [11] P.-M. Léger, P. Charland, H. Feldstein, J. Robert, G. Babin, and D. Lyle, “Business simulation training in information technology education: Guidelines for new approaches in it training,” *Journal of Information Technology Education: Research*, vol. 10, pp. 39–53, Jan. 2011.
- [12] T. Beranič and M. Heričko, “Introducing erp concepts to it students using an experiential learning approach with an emphasis on reflection,” *Sustainability*, vol. 11, no. 18, 2019, ISSN: 2071-1050. DOI: 10.3390/su11184992. [Online]. Available: <https://www.mdpi.com/2071-1050/11/18/4992>.
- [13] T. Beranič and M. Heričko, “The impact of serious games in economic and business education: A case of erp business simulation,” *Sustainability*, vol. 14, no. 2, 2022, ISSN:

2071-1050. DOI: 10.3390/su14020683. [Online]. Available: <https://www.mdpi.com/2071-1050/14/2/683>.

- [14] M. Heričko, K. Kerman, and T. Beranič, “Avoiding the risks of overgamification in education – a case of erpsim,” in *Learning Technology for Education Challenges*, L. Uden and D. Liberona, Eds., Cham: Springer International Publishing, 2021, pp. 124–137, ISBN: 978-3-030-81350-5.



# Reprints





# An Overview of Methods for Generating, Augmenting and Evaluating Room Impulse Response Using Artificial Neural Networks

Mantas Tamulionis

Vilnius Gediminas Technical University, Saulėtekio al. 11, Vilnius, Lithuania  
mantas.tamulionis@vilniustech.lt

**Abstract.** *Methods based on artificial neural networks (ANN) are widely used in various audio signal processing tasks. This provides opportunities to optimize processes and save resources required for calculations. One of the main objects we need to get to numerically capture the acoustics of a room is the room impulse response (RIR). Increasingly, research authors choose not to record these impulses in a real room but to generate them using ANN, as this gives them the freedom to prepare unlimited-sized training datasets. Neural networks are also used to augment the generated impulses to make them similar to the ones actually recorded. The widest use of ANN so far is observed in the evaluation of the generated results, for example, in automatic speech recognition (ASR) tasks. This review also describes datasets of recorded RIR impulses commonly found in various studies that are used as training data for neural networks.*

**Keywords.** Room impulse response, reverberation, acoustic simulation, data augmentation, artificial neural networks, speech recognition.

## 1 Introduction

Room impulse response is a transfer function that describes the acoustics of a room, corresponding to one specific position between the sound source and the listener. Features of the RIR depend on the geometry of the room, the absorption and scattering coefficients of the surfaces, the distances of the source and receiver to the nearest reflecting surface and to each other. The RIR consists of silence at the beginning (its duration determines how long it takes for the signal to travel to the receiver), as well as early and late reflections. We can convolve the RIR with an anechoic signal and thus place the signal virtually in the desired room. We can record the RIR in a real room, but if there is at least a slight change in the position of the source or receiver, we should repeat the recording. It can also be modeled using acoustic modeling algorithms, there are popular commercial applications such as ODEON or CATT-Acoustic, but using these applications it is very difficult to obtain authenticity due to the standard absorption coefficients assigned to the surfaces. These algorithms generate RIR using the Image source method (ISM). This method allows us to expect realistic results only if we model an almost empty room with standard geometric shapes. With the development of ANN technologies, in recent years, they have also been applied to the estimation of RIRs. ANN can be used not only to generate RIRs, but also to augment impulses generated by other methods to make them similar to recorded RIRs. ANN can also be used to perform evaluation tasks on proposed RIR generation methods. In this review, we will discuss methods for applying ANN to achieve all of these goals.

## 2 Estimation and generation methods

Tang et al. proposed a new geometric acoustic simulation method (GAS), which was compared with the ISM method. The article states that this method allows to model not only specular but also diffuse reflections, which makes it possible to simulate rooms with much more complex geometric shapes and more reflective surfaces (Tang et al., 2020a). GAS is based on Monte Carlo path tracing, which differs from the ISM method in that the reflections are generated in randomly selected directions. The authors report that their proposed method cannot model diffraction and low frequency reflections. This algorithm does not use neural networks to generate RIRs, but they are used in evaluation tasks and will be discussed in Section 4.

Ratnarajah and colleagues presented a method for generating RIRs using the Generative Adversarial Network (GAN) and named it IR-GAN. The authors used the WaveGAN structure for their work, which was originally designed to generate short audio files (Donahue et al., 2019). The structure of WaveGAN is one-dimensional deep convolutional generative adversarial networks (DCGANs) that first generate a spectrogram and then convert it into an audio signal. In this case, the GAN trained from a dataset of RIRs recorded in a real room, and could later change the acoustic parameters of the generated RIRs, such as reverberation time (RT60), direct to reverberant ratio (DRR) and others, to generate an unlimited number

of new RIRs simulating new rooms (Ratnarajah et al., 2020). It should be noted that the authors converted the recorded RIRs to 16 kHz before sending them to the network for training, which means that high frequency energy is removed from the RIRs.

Yu and Kleijn presented a method for estimating room acoustic parameters. Separate algorithms estimate the geometry of the room and the absorption coefficients of its surfaces. Convolutional neural networks (CNNs) are used to estimate geometry, and feedforward multilayer perceptrons (MLPs) are used to estimate absorption coefficients (Yu & Kleijn, 2021). The authors state that satisfactory results can be achieved by training neural networks with only one RIR impulse, although increasing the learning dataset slightly improves the performance of the algorithms.

For room geometry estimation, the CNN consisting of eight one-dimensional convolutional layers and three fully connected layers was used. Each convolutional layer was followed by a one-dimensional batch normalization layer and a leaky rectified linear unit (Leaky ReLU) activation function. The CNN at its end has three output nodes that provide the length, width, and height of the room. CNN was first trained with simulated RIRs, later the model was adapted to work well with recorded RIRs. The simulated RIRs were generated by the ISM method.

The estimation of surface absorption coefficients was tested only on a set of simulated RIR data, as databases of recorded RIRs together with their absorption coefficients are not usually available. Both in the geometry estimation and at this stage, time domain RIRs were used. Surface absorption coefficients usually differ when analyzing individual frequencies, so the authors performed an additional processing step before sending impulses to neural networks - dividing RIRs into several frequency bands. In this way, the estimation can be performed for each frequency band separately. Chebyshev type I, 10th order filters were chosen for filtering as it allowed to achieve higher computational speed. The MLP used for this estimation had nine hidden layers, the number of neurons in each of them was halved from 2048 to 8 neurons each time. A rectified linear unit (ReLU) activation function was used after each hidden layer.

### 3 Datasets

In the ASpIRE (Automatic Speech Recognition In Reverberant Environments) challenge, participants worked with different datasets for training, development and evaluation (Harper, 2015). The Fisher conversational telephone corpus dataset (Cieri et al., 2004), which contains more than 10,000 telephone conversations in English was provided for training. The Mixer 6 corpus dataset (Brandschain et al., 2010), which contains 1.425 telephone conversations recorded in two different rooms using 15 differently arranged microphones, was designed for development. A new database for the evaluation of algorithms was created and named "Mixer 8 pilot corpus". It differed from the Mixer 6 corpus in that recordings were made in seven different rooms using 8 microphones spaced at different distances.

Ko et al. in their study compared the simulated and recorded RIRs. They compiled a recorded RIRs database consisting of the RWCP (Nakamura et al., 2000), the REVERB challenge (Kinoshita et al., 2013), and the Aachen impulse response (AIR) datasets (Jeub et al., 2009). They were able to achieve satisfactory results in the study only after adding point-source noises to the simulated RIRs. These noises were taken from the MUSAN (music, speech, and noise corpus) database (Snyder et al., 2015).

The authors of IR-GAN compared the RIRs generated by their method with the recorded RIRs of BUT ReverbDB (Szoke et al., 2019) and the aforementioned AIR database. Additionally, in this study, anechoic signals from the LibriSpeech database (Panayotov et al., 2015) were used, which were convolved with both simulated and recorded RIRs. From the BUT ReverbDB database, the authors additionally used environmental noise files that were added to the convolved signals in an attempt to generate the far field signals required for ASR tests.

Yu and Kleijn also used BUT ReverbDB data in their experiments as a set of recorded RIR data. This decision was made due to the large number of impulses in the set from different types of rooms that were not empty during the measurement. The dataset consists of an average of 155 RIRs from each room (5 source and 31 receiver positions). The RT30 parameter of the rooms ranged between 0.59 and 1.85 s. The dataset also contains geometric information for all measured rooms. The simulated RIR dataset was generated using a Room Impulse Response Generator (Habets, 2010) with a sampling rate of 8kHz and a RIR length of 4096 samples, which allowed the generation of impulses lasting approximately 0.5 s. The recorded RIR dataset had a higher sampling rate, but before applying these impulses to neural networks, the authors converted the dataset to a 8 kHz sampling rate, truncated, and continued to use only 4096 samples.

## 4 Data augmentation methods

Ko and colleagues conducted a study to determine how the difference between the results of the ASR test could be eliminated when simulated and recorded RIRs are used in different tests (Ko et al., 2017). It was found that the ASR test results are significantly improved if we add point-source noises to the simulated RIRs. Table 1 shows how the word error rate (WER) values differ when the same acoustic model is trained on different data – using the point-source noise addition method and without using any augmentation method.

**Table 1.** Differences in WER values when one of the augmentation methods is applied to the training data of the algorithm

Algorithm / authors	Augmentation method used	WER [%]
Ko et al.	Without augmentation	40.9
	Addition of point-source noises	27.0
IR-GAN	Without augmentation	19.71
	Constraint method	14.99

The authors of the IR-GAN algorithm had to solve the problem arising from the ability of GAN network to generate an unlimited variety of RIR impulses. There was a high probability that the generated RIRs would be noisy and have an unrealistically large reverberation time. A constraint method was used, which allowed to limit the variety of generated RIRs (Ratnarajah et al., 2020). The limits of the changes in the main acoustic parameters were calculated from the training data, and when generating new RIRs, the GAN network was not allowed to exceed these limits. Table 1 also shows how the WER value improves in the implementation of the IR-GAN algorithm by additionally applying this constraint method.

To adapt the room geometry estimation algorithm proposed by Yu and Kleijn for use with recorded RIRs, the authors used the insights of the SpecAugment method (Park et al., 2019) and added 30–50 dB signal-to-noise ratio (SNR) additive noise to the simulated RIRs (Yu & Kleijn, 2021). Moreover, RIRs generated by the ISM method usually lack information about obstacles and additional objects that can interfere with the sound wave. In real rooms, these objects block the trajectories of reflections or create unusual new reflections. To solve this problem, it is possible to remove or add randomly selected reflections from simulated RIRs or to add blocked reflection structures taken from recorded RIRs. The authors used the adaptive rectangular decomposition (ARD) method (Raghuvanshi et al., 2009) and thus tried to simulate possible obstacles in the room for simulated RIRs.

**Table 2.** Differences in RMSE values when one of the augmentation methods is removed from the system

<b>Bypassed data augmentation method</b>	<b>Average RMSE [m]</b>
Addition of noise	0.0310
Adding / removing reflections	0.0570
Adding blocked reflection structures	0.0648
ARD method	0.1210

Table 2 shows the root mean square error (RMSE) differences, which represent the accuracy of the results generated by the algorithm compared to known room geometry data. The algorithm uses all augmentation methods listed above. To identify the importance of each of the methods, the experiments were repeated, each time a different method of augmentation was bypassed. From the results, we can see that after the deactivation of the ARD method, the RMSE value increased the most, which means that the use of this method ensures the highest accuracy of the results.

## 5 Evaluation methods

Intelligence Advanced Research Projects Activity (IARPA) organized a competition called the ASPIRE challenge (Harper, 2015). Those wishing to participate had to develop ASR systems without access to matched data for system training and development. This competition was for the evaluation of far-field recordings and differed from previous

competitions in that the algorithms had to work with conversation-type voice data, the number of words in the vocabulary used was not limited, which means that the evaluation dataset could contain words that were not in the training dataset. Participants were not provided with any information about the audio files in the dataset. The algorithm proposed by the winner of this competition used the ROVER system (Fiscus, 1997), which allows to combine several different ASR models and thus obtain better results. In this case, the combination of Gaussian Mixture Models (GMMs) and Deep Neural Networks (DNNs) gave the best results (Hsiao et al., 2015).

In the Ko study, the results were evaluated by performing Large Vocabulary Continuous Speech Recognition (LVCSR) tasks. Tasks were performed using Time-delay neural network (TDNN) and bi-directional long-short-term memory (BLSTM) acoustic models. The authors state that using the RIRs generated by their method, with the added point-source noise, the BLSTM model can achieve a WER value of 24.6% (Ko et al., 2017).

The results of the GAS algorithm are evaluated by performing ASR and Keyword spotting (KWS) tasks. The ASR task was performed using an acoustic model that consists of two layers of two-dimensional convolutional neural network (2D CNN) and five layers of long short-term memory (LSTM). The model used for the KWS task consists of a single-layer 1D CNN and a two-layer LSTM. The ASR task on the BUT ReverbDB database achieved a WER value of 16.53%. The results of the KWS task are measured by equal error rates (EERs). The authors show that their proposed GAS method can reduce EER values by 21% compared to the ISM method (Tang et al., 2020a).

The authors of the IR-GAN algorithm also evaluate the generated RIRs by performing an ASR test, using the Kaldi LibriSpeech acoustic model, which is based on the TDNN network (Tang et al., 2020b). The paper states that the proposed algorithm can reduce WER by almost 9% compared to the GAS method. However, this can only be achieved when the AIR dataset is selected as the training set. The authors also show that by combining RIRs generated by IR-GAN and GAS algorithms, WER can be reduced by more than 14% (Ratnarajah et al., 2020).

**Table 3.** Comparison of different algorithms, databases used, ASR models and WER results obtained

Method/ authors	Dataset	ASR model	WER [%]
Hsiao et al.	Fisher	GMM & DNN	27.1
Ko et al.	RWCP + REVERB + AIR	BLSTM	24.6
GAS	BUT	2D CNN & LSTM	16.53
IR-GAN	BUT	TDNN	14.99
IR-GAN	AIR	TDNN	7.71

The results of Yu and Kleijn’s room geometry estimation algorithm are compared with another algorithm using the graph-based echo labeling method (Jager et al., 2016). It should be noted that the recordings, selected in this study for comparison, had a sampling frequency of 96 kHz, while the authors used sampling frequency of 8 kHz. The authors showed that

both methods achieve almost identical average error, but the algorithm proposed by Yu and Kleijn can offer significantly better computational efficiency – even  $10^4$  shorter working time due to the lower sampling rate used. Comparing the known room geometry parameters and those estimated by neural networks, the authors were able to achieve a minimum average error of 4 cm for the simulated RIR data and 6.5 cm for the recorded RIR data. The smallest error in estimating absorption coefficients was 0.09 (Yu & Kleijn, 2021).

## 6 Conclusions

In this review, we discussed the use of ANN to generate, augment and evaluate RIRs. From the reviewed studies, we see that GAN, CNN, and MLP networks are used to generate RIRs as well as to estimate room geometry and absorption coefficients. In most studies, the authors have shown that better results can be achieved by applying additional augmentation to the generated RIRs. We can also conclude that the choice of datasets for training, as well as the choice of an acoustic model consisting of certain neural networks, strongly determines the results obtained when performing evaluation tasks of the generated RIRs, such as ASR. The authors of the IR-GAN algorithm, whose acoustic model was based on the TDNN, achieved the best results. They were able to obtain the best WER value when the AIR dataset was selected as the training data.

## References

- Brandschain, L., Graff, D., Cieri, C., Walker, K., Caruso, C., & Neely, A. (2010). *The Mixer 6 corpus: Resources for cross-channel and text independent speaker recognition* [Conference presentation]. Proceedings of 7th International Conference on Language Resources and Evaluation (LREC), Valletta, Malta.
- Cieri, C., Miller, D., & Walker, K. (2004). *The Fisher Corpus: a resource for the next generations of speech-to-text* [Conference presentation]. Proceedings of 4th International Conference on Language Resources and Evaluation (LREC), Lisbon, Portugal.
- Donahue, C., McAuley, J., & Puckette, M. (2019). *Adversarial audio synthesis* [Conference presentation]. Proceedings of International Conference on Learning Representations.
- Fiscus, J. G. (1997). *A post-processing system to yield reduced word error rates: Recognizer Output Voting Error Reduction (ROVER)* [Conference presentation]. Proceedings of IEEE Workshop on Automatic Speech Recognition and Understanding, Santa Barbara, CA, USA. <https://doi.org/10.1109/ASRU.1997.659110>
- Habets, E. (2010). *Room impulse response generator*. <https://www.audiolabs-erlangen.de/fau/professor/habets/software/rir-generator>

- Harper, M. (2015). The Automatic Speech recognition in Reverberant Environments (ASpIRE) challenge. In *Proceedings of IEEE Workshop on Automatic Speech Recognition and Understanding (ASRU)* (pp. 547–554). Institute of Electrical and Electronics Engineers. <https://doi.org/10.1109/ASRU.2015.7404843>
- Hsiao, R., Ma, J., Hartmann, W., Karafiat, M., Grezl, F., Burget, L., Szoke, I., Cernocky, J., Watanabe, S., Chen, Z., Mallidi, S. H., Hermansky, H., Tsakalidis, S., & Schwartz, R. (2015). Robust speech recognition in unknown reverberant and noisy conditions. In *Proceedings of IEEE Workshop on Automatic Speech Recognition and Understanding (ASRU)* (pp. 533–538). Institute of Electrical and Electronics Engineers. <https://doi.org/10.1109/ASRU.2015.7404841>
- Jager, I., Heusdens, R., & Gaubitch, N. D. (2016). Room geometry estimation from acoustic echoes using graph-based echo labeling. In *Proceedings of International Conference on Acoustics, Speech, and Signal Processing* (pp. 1–5). Institute of Electrical and Electronics Engineers. <https://doi.org/10.1109/ICASSP.2016.7471625>
- Jeub, M., Schäfer, M., & Vary, P. (2009). A binaural room impulse response database for the evaluation of dereverberation algorithms. In *Proceedings of 16th International Conference on Digital Signal Processing* (pp. 1–5). Institute of Electrical and Electronics Engineers. <https://doi.org/10.1109/ICDSP.2009.5201259>
- Kinoshita, K., Delcroix, M., Yoshioka, T., Nakatani, T., Habets, E., Haeb-Umbach, R., Leutnant, V., Sehr, A., Kellermann, W., Mass, R., Gannot, S., & Raj, B. (2013). The reverb challenge: A common evaluation framework for dereverberation and recognition of reverberant speech. In *Proceedings of IEEE Workshop on Applications of Signal Processing to Audio and Acoustics* (pp. 1–4). Institute of Electrical and Electronics Engineers. <https://doi.org/10.1109/WASPAA.2013.6701894>
- Ko, T., Peddinti, V., Povey, D., Seltzer, M. L., & Khudanpur, S. (2017). A study on data augmentation of reverberant speech for robust speech recognition. In *Proceedings of International Conference on Acoustics, Speech and Signal Processing (ICASSP)* (pp. 5220–5224). Institute of Electrical and Electronics Engineers. <https://doi.org/10.1109/ICASSP.2017.7953152>
- Nakamura, S., Hiyaue, K., Asano, F., Nishiura, T., & Yamada, T. (2000). *Acoustical sound database in real environments for sound scene understanding and hands-free speech recognition* [Conference presentation]. Proceedings of 2nd International Conference on Language Resources and Evaluation (LREC 2000), Athens, Greece.
- Panayotov, V., Chen, G., Povey, D., & Khudanpur, S. (2015). Librispeech: An ASR corpus based on public domain audio books. In *Proceedings of International Conference on Acoustics, Speech and Signal Processing (ICASSP)* (pp. 5206–5210). Institute of Electrical and Electronics Engineers. <https://doi.org/10.1109/ICASSP.2015.7178964>



- 
- Park, D. S., Chan, W., Zhang, Y., Chiu, C. C., Zoph, B., Cubuk, E. D., & Le, Q. V. (2019). SpecAugment: A simple data augmentation method for automatic speech recognition. In *Proceedings of the Annual Conference of the International Speech Communication Association* (pp. 2613–2617). ISCA. <https://doi.org/10.21437/Interspeech.2019-2680>
- Raghuvanshi, N., Narain, R., & Lin, M. C. (2009). Efficient and accurate sound propagation using adaptive rectangular decomposition. *IEEE Transactions on Visualization and Computer Graphics*, *15*(5), 789–801. <https://doi.org/10.1109/TVCG.2009.28>
- Ratnarajah, A., Tang, Z., & Manocha, D. (2020). *IR-GAN: room impulse response generator for speech augmentation*. <http://arxiv.org/abs/2010.13219>
- Snyder, D., Chen, G., & Povey, D. (2015). *MUSAN: a music, speech, and noise corpus*. <http://arxiv.org/abs/1510.08484>
- Szoke, I., Skacel, M., Mosner, L., Paliesek, J., & Cernocky, J. H. (2019). Building and evaluation of a real room impulse response dataset. *IEEE Journal on Selected Topics in Signal Processing*, *13*(4), 863–876. <https://doi.org/10.1109/JSTSP.2019.2917582>
- Tang, Z., Chen, L., Wu, B., Yu, D., & Manocha, D. (2020a). Improving Reverberant Speech Training Using Diffuse Acoustic Simulation. In *Proceedings of International Conference on Acoustics, Speech, and Signal Processing* (pp. 6969–6973). Institute of Electrical and Electronics Engineers. <https://doi.org/10.1109/ICASSP40776.2020.9052932>
- Tang, Z., Meng, H. Y., & Manocha, D. (2020b). Low-frequency compensated synthetic impulse responses for improved far-field speech recognition. In *Proceedings of International Conference on Acoustics, Speech and Signal Processing (ICASSP)* (pp. 6974–6978). Institute of Electrical and Electronics Engineers. <https://doi.org/10.1109/ICASSP40776.2020.9054454>
- Yu, W., & Kleijn, W. B. (2021). Room acoustical parameter estimation from room impulse responses using deep neural networks. *IEEE/ACM Transactions on Audio Speech and Language Processing*, *29*, 436–447. <https://doi.org/10.1109/TASLP.2020.3043115>



# Analysis of Linux OS Security Tools for Packet Filtering and Processing

Dmitrij Melkov<sup>1</sup>, Šarūnas Paulikas<sup>1</sup>

<sup>1</sup> Vilnius Gediminas Technical University, Saulėtekio al. 11, Vilnius, Lithuania  
{dmitrij.melkov, sarunas.paulikas}@vilniustech.lt

**Abstract.** *Open-source software and its components are widely used in various products, solutions, and applications, even in closed-source. Majority of them are made on Linux or Unix based systems. Netfilter framework is one of the examples. It is used for packet filtering, load-balancing, and many other manipulations with network traffic. Netfilter based packet filter iptables has been most common firewall tool for Linux systems for more than two decades. Successor of iptables – nftables was introduced in 2014. It was designed to overcome various iptables limitations. However, it hasn't received wide popularity and transition is still ongoing. In recent years researchers and developers around the world are searching for solution to increase performance of packet processing tools. For that purpose, many of them trying to utilize eBPF (Extended Berkeley Packet Filter) with XDP (Express Data Path) data path. This paper focused on analyzing Linux OS packet filters and comparing their performances in different scenarios.*

**Keywords.** Linux, Netfilter, iptables, nftables, eBPF, XDP, firewalls, packet filters.

## 1 Introduction

Nowadays, open-source software is extensively used in many different areas and devices. From supercomputers and enterprise level network devices to smartphones and various Internet of Things (IoT) devices. Open-source software is decentralized in many cases, so multiple stakeholders can do adjustments or fixes. Development of open-source software is rapid, and it is basically open to everyone without any cost. So, it is quite clear why it has achieved such popularity.

In networking, open-source code is also playing a major role. TCP/IP stack in Linux and Unix systems is solid, mature and offers switching, routing, firewalling, and other functionality with possibility to tune it for various purposes. That is why it is widely used by many companies in their proprietary software and hardware products using proprietary software. Cisco Open NX-OS is built on Linux kernel (Cisco DevNet, 2021). Others Cisco's operating systems such as IOS-XE, NX-OS are also built on Linux. Juniper's Junos OS Evolved runs natively on Linux whereas classical Junos OS runs over an instance of the FreeBSD (Juniper Networks, 2021). Citrix Systems Netscaler software is also based on FreeBSD (Citrix, 2017).

Additionally, in a lot of Linux based systems Netfilter framework is utilized for packet filtering, load-balancing and other manipulations with IP packets. The most famous Netfilter's utility iptables was introduced back in 1998. It became a standard for firewalling tools. However, various architectural limitations of iptables have pushed developers to introduce his successor – nftables. It overcomes main iptables limitations (Westphal, 2016). For example, addition and removal of rules is now atomic, it is especially useful for applications such as Kubernetes or Red Hat's OpenShift where ruleset updates are constant and very frequent. Most rule handling was moved to userspace. Support of new protocol will not require to implement kernel changes. Instead, only nft tool needs to be updated. Since version 3.13 nftables was merged into the Linux kernel. Despite all advantages, full migration from iptables to nftables has not happened yet. In 2018 iptables was considered a legacy tool and iptables-nft tool was released to translate iptables rules into nftables and to enforce migration.

Increasing network speeds and transferred data rate has led Linux community to think about alternative options of iptables replacer. In recent years, a lot of attention is focused on using eBPF functionality to make iptables alternative based on it. First results are showing that performance gain could be quite significant. What was one of the controversies in case of nftables.

This paper is structured as follows. In "Related Work" section results of similar works are presented. In section "Packet flow in Netfilter and eBPF" packet flow in iptables, nftables and eBPF is discussed. Our measurement results of UDP traffic are presented in section "Experimental results". Conclusions are provided in last section.

## 2 Related works

In our previous work “Performance Testing of Linux Firewalls” (Melkov et al., 2020) we measured how TCP throughput depends on number of installed rules in iptables or nftables. Experiment was done using different Netfilter chains: PREROUTING, INPUT, FORWARD, OUTPUT. Different amount of virtual CPU (vCPU) was used on virtual machine with installed iptables or nftables. Results showed performance advantage of iptables over nftables in all scenarios. Best result was achieved using ipset extension. Scholz et al. (2018) examined how number of processed packets per second depends on number of rules in iptables and nftables. Then they compared these results with results when XDP was used. XDP utilize eBPF virtual machine to process packets before they reach kernel. With such set-up they were able to reach four times better results than using iptables and nftables. Bertrone et al. (2018a) in paper “Toward an eBPF-based clone of iptables” proposed architecture of a possible replacement of iptables with an equivalent software based on eBPF technology. They proposed how to implement matching algorithm and connection tracking using eBPF preserving iptables semantic and syntax. In their another paper “Accelerating Linux Security with eBPF iptables” (Bertrone et al., 2018b) they made performance tests of iptables and their designed iptables alternative – bpf-iptables. Two different tests were done. In first test they measured UDP throughput in FORWARD chain and in second test TCP throughput was measured in INPUT chain. In both cases custom bpf-iptables tool outperformed standard iptables. Greater advantage seen with increased number of installed rules. In further work from same authors “Securing Linux with a Faster and Scalable Iptables” (2019) they did nftables performance test in same scenarios. Results were worse than using custom created bpf-iptables and standard iptables. Tumolo from Politecnico di Torino in his master thesis “Toward a faster iptables in eBPF” (Tumolo, 2018) implemented his own version of iptables using eBPF and measured UDP throughput and ICMP latency. Results were compared with standard iptables results. Higher throughput and lower latency were achieved using his custom created bpf-iptables tool. Article “Benchmarking nftables” published by Sutter (2017) confirms other performance testing of iptables and nftables. In this article nftables was able to outperform iptables only in scenario when native nftables set functionality was used. Using this functionality, it is possible to add multiple targets into single match rule. But same result could be achieved using ipset extension for iptables. It was confirmed in the same article and in our previous paper.

## 3 Packet flow in Netfilter and eBPF

In case of Netfilter/iptables each packet travels through several chains and tables. First, every packet that enters system will go through Raw, Mangle and NAT tables of PREROUTING chain. If packet destined to local applications, it would enter INPUT chain and will go through Mangle and Filter tables. Otherwise, when packet should be routed, it will enter FORWARD chain and will go through same tables as in INPUT chain. If packet was locally generated, it

enters OUTPUT chain and will also go through Raw, Mangle, NAT, and Filter tables. At the very end of the path, every packet enters POSTROUTING chain which contains mangle and NAT tables. In case of iptables packet will go through all chains. Unlike iptables, nftables does not have all chains and tables by default. So, it is up to user to determine which chains and tables should be used (Suehring, 2015).

eBPF programs can be attached even before packet enter PREROUTING chain of Netfilter. eBPF based program XDP provides possibility to process packets before TCP/IP stack achieving higher performance of packet processing (Miano et al., 2019b). Location of Netfilter's chains, most popular tables and eBPF hooks are shown in Figure 1.

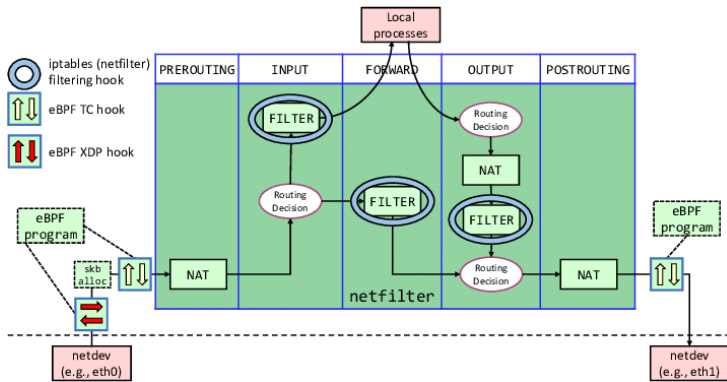

**Figure 1.** Location of Netfilter chains and eBPF hooks (Miano et al., 2019a)

## 4 Experimental results

Experiment was done in network laboratory at the Faculty of Electronics of the Vilnius Tech University. We used same testbed as in our previous work (Melkov et al., 2020). It was designed according to recommendations provided in RFC 3511.

Testbed was made from 2 IBM System x3550 M3 servers with installed ESXi hypervisor and physical switch Cisco Catalyst 3650 series. VM with installed iptables version 1.8.3 was hosted on ESXi server with 12 CPU  $\times$  2.40 GHz and 96 GB of RAM. To translate rules of iptables into nftables, iptables-nft tool was used. Sender and receiver VM's were hosted on another ESXi server with 8 CPU  $\times$  2.4 GHz and 96 GB of RAM. For each VM we dedicated 8 GB of RAM and 2 vCPU. As operating system we used Ubuntu 18.10 version. To ensure L3 connectivity, sender and receiver had IP addresses from different subnets and were connected to separate virtual Switch (vSwitch). VM with installed packet filter had two interfaces, one for subnet of sender and another for subnet of receiver. Each interface was connected to separate vSwitch. Two 1 Gb/s uplinks from each ESXi server were connected to physical Cisco switch. Logical diagram of testbed is shown in Figure 2. For traffic generation and analysis iPerf tool was used. Measurements were done in FORWARD and INPUT chains of iptables and nftables using 1, 2 and 4 dedicated vCPU for VM. We measured three different UDP flows. First flow consisted of 128 B packets with 15 Mbps bandwidth, second

flow consisted of 512 B packets with 30 Mbps bandwidth and third flow consisted of 1280 B packets with 45 Mbps flow. Measurements for each flow were done separately. For the beginning, VM with installed packet filter had 2 dedicated vCPU.

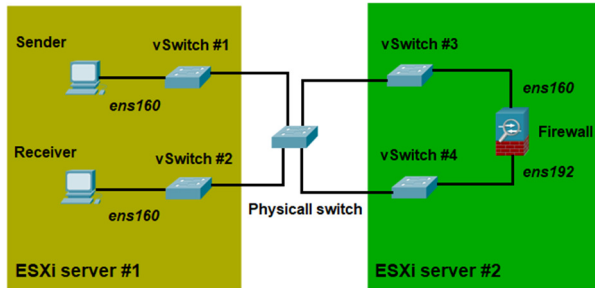

Figure 2. Logical network diagram of testbed (Melkov et al., 2020)

Experimental results of iptables are shown in Figure 3. As we can see from the graph, in case of 15 Mbps flow of 128B packets degradation starts at around 5 thousand installed rules. Degradation means that packet filter is not able to process all UDP packets and starts to drop some of them. When 30 Mbps flow consists of 512 B packets degradation starts at around 11 thousand installed rules and in case of 45 Mbps flow that consists of 1280 B packets degradation starts at around 20 thousand rules. After the point when packet filter has more than 20 thousand installed rules number of processed packets per second decreases in same manner for each flow. So, at this point there is no difference for firewall what size packets are, as number of processed packets will remain the same. Then we repeated measurements, but filtering was done in INPUT chain. In that scenario receiver was VM with installed packet filter itself. In contrast to our previous work (Melkov et al., 2020), when TCP throughput was better in INPUT chain, in case of UDP traffic results were the same as in FORWARD chain. Also, there were no difference in results with 1 or 4 dedicated vCPU.

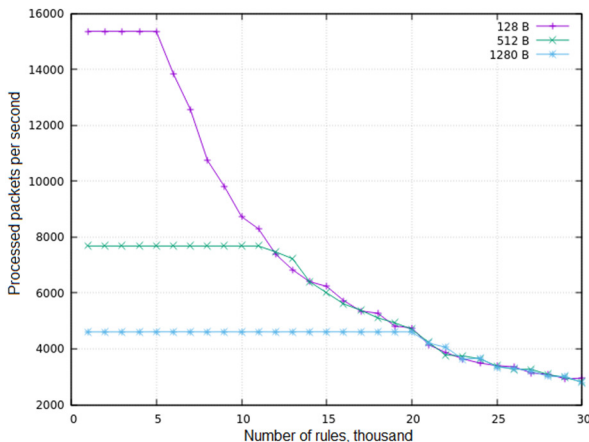

Figure 3. Processed UDP packets per second using iptables

Same measurements were done filtering packets with nftables instead of iptables. Experimental results are shown in Figure 4. Performance of nftables worse than iptables as decrease in number of processed packets per seconds starts earlier. It starts at around 1, 2 and 3.5 thousand of installed rules for 128 B, 512 B and 1280 B packets accordingly. As in previous case, performance of filtering packet in FORWARD and INPUT chain is the same.

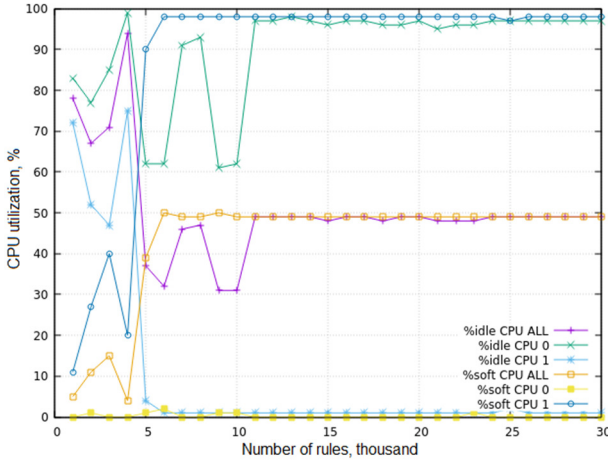

Figure 4. Processed UDP packets per second using nftables

In Figure 5 advantage of iptables over nftables are shown. As we can see from this picture, advantage is greater with smaller size packets. It increases with number of installed rules into packet filter. With 6 thousand rules installed, iptables processing around 5.2 times more 128 B packets. In case of 512 B and 1280 B packets advantage is around 2.9 and 1.7 times accordingly.

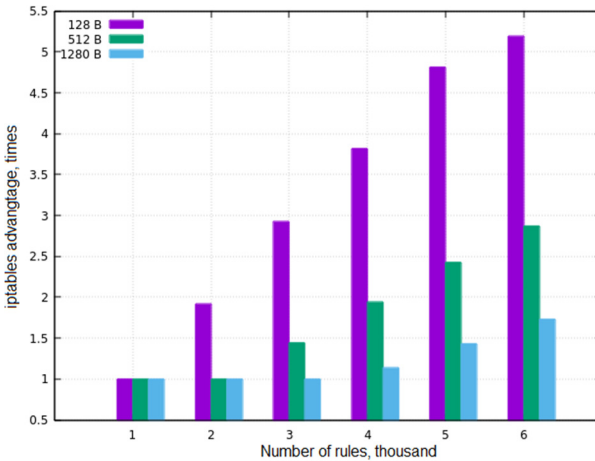

Figure 5. Advantage of iptables over nftables



In order to find reason of decrease in number of processed packets we tried to measure CPU utilization during the tests on VM where packet filter was installed. We were able to find relation between CPU performance decrease and CPU utilization. On Figure 6 CPU utilization during iptables test with 128 B packets are shown. As we can see from this graph, when number of installed rules is lower than 5 thousand there are some fluctuations of CPU utilization. But when there are more than 5 thousand installed rules usage of CPU1 for handling software interrupts reaching almost 100%, while CPU0 is idle for almost 100%. Breaking point of 5 thousand rules are the same as the point of performance degradation in Figure 3 for 128 B packets. In Figure 7 CPU utilization during test of iptables with 1280 B packets are shown. Again, CPU1 was utilized for almost 100% starting at around 20 thousand rules. It matches degradation point of flow with 1280 B packets as in Figure 3. Same CPU utilization pattern was also visible in case of using nftables.

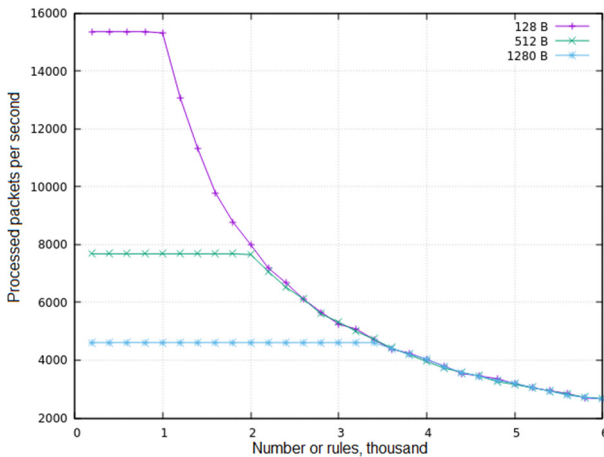

Figure 6. CPU utilization filtering 128 B packets in iptables

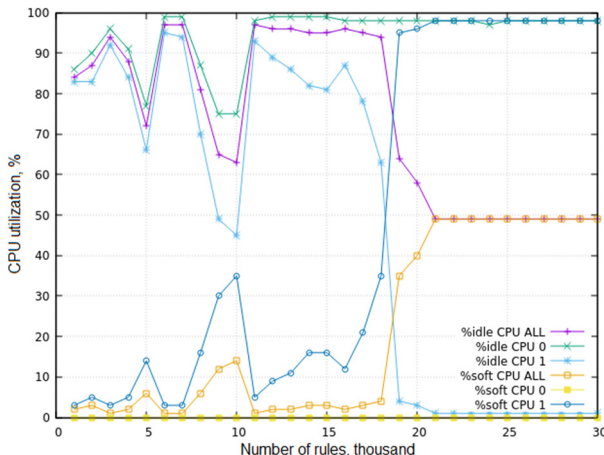

Figure 7. CPU utilization filtering 1280 B packets in iptables

## 5 Conclusions

Development of open-source packet filtering tool attracts a lot of attention from developers and researchers. The main goals are to overcome limitations of iptables and to achieve higher filtering performance. Nftables solves a lot of limitations. However, our and other benchmarks shows that if entire rule set is not designed for nftables, performance is worse than using standard iptables (Tumolo, 2018). It is problem for applications such as Kubernetes that uses iptables as transition to nftables without performance degradation will require change of ruleset's logic. Use of eBPF virtual machine with XDP program can bring significant increase of performance, but still a lot of work should be done to keep various Netfilter functionality such as connection tracking and other.

In our paper we presented how number processed UDP packets per second depend on number of installed rules into iptables or nftables packet filter. It was concluded, that iptables outperforms nftables. Also, performance is not depending on chain where filtering is performed and not depending on amount of dedicated vCPU for VM with installed packet filter. We noticed, that packet filters use only single vCPU during processing of UDP packets.

So far researcher's attention mainly focused on measuring TCP throughput when filtering is performed in eBPF virtual machine. Our future works should be focused on measuring UDP flow characteristics (packet loss, latency, jitter) while eBPF and XDP technologies are used for filtering.

## References

- Bertrone, M., Miano, S., Pi, J., Risso, F., & Tumolo, M. (2018a). *Toward an eBPF-based clone of iptables* [Conference presentation]. The Technical Conference on Linux Networking, Montreal, Canada.
- Bertrone, M., Miano, S., Risso, F., & Tumolo, M. (2018b). *Accelerating Linux security with eBPF iptables* [Conference presentation]. The ACM SIGCOMM 2018 Conference, Budapest, Hungary. SIGCOMM. <https://doi.org/10.1145/3234200.3234228>
- Cisco DevNet. (2021). *Open NX-OS Linux*. <https://developer.cisco.com/docs/nx-os/#!open-nx-os-linux/open-nx-os-linux>
- Citrix. (2017). *How to check the version of FreeBSD on NetScaler*. <https://support.citrix.com/article/CTX221291>
- Juniper Networks. (2021). *Junos OS Evolve overview*. <https://www.juniper.net/documentation/us/en/software/junos/evo-overview/topics/concept/evo-overview.html>

- 
- Melkov, D., Šaltis, A., & Paulikas, Š. (2020). *Performance testing of Linux firewalls* [Conference presentation]. 2020 IEEE Open Conference of Electrical, Electronic and Information Sciences (eStream), Vilnius, Lithuania. IEEE. <https://doi.org/10.1109/eStream50540.2020.9108868>
- Miano, S., Bertrone, M., Risso, F., Vásquez Bernal, M., Lu, Y., & Pi, J. (2019a). Securing Linux with a faster and scalable iptables. *ACM SIGCOMM Computer Communication Review*, 49(3), 2–17. <https://doi.org/10.1145/3371927.3371929>
- Miano, S., Doriguzzi-Corin, R., Risso, F., Siracusa, D., & Sommese, R. (2019b). Introducing SmartNICs in server-based data plane processing: the DDoS mitigation use case. *IEEE Access*, 7, 107161–107170. <https://doi.org/10.1109/ACCESS.2019.2933491>
- Scholz, D., Raumer, D., Emmerich, P., Kurtz, A., Lesiak, K., & Carle, G. (2018). *Performance implications of packet filtering with Linux eBPF* [Conference presentation]. 30th International Teletraffic Congress, Vienna, Austria. IEEE. <https://doi.org/10.1109/ITC30.2018.00039>
- Suehring, S. (2015). *Linux Firewalls: Enhancing security with nftables and beyond* (4th ed.). Addison-Wesley.
- Sutter, P. (2017). Benchmarking nftables. *Red Hat Developer blog*. <https://developers.redhat.com/blog/2017/04/11/benchmarking-nftables>
- Tumolo, M. (2018). *Towards a faster iptables in eBPF* [Master thesis]. Politecnico di Torino.
- Westphal, F. (2016). What comes after “iptables”? Its successor, of course “nftables”. *Red Hat Developer blog*. <https://developers.redhat.com/blog/2016/10/28/what-comes-after-iptables-its-successor-of-course-nftables>



# ATHENA Research Book, Volume 1

Györkös, J. et al. (ed.)

**Abstract.** *The ATHENA European University is an alliance of nine Higher Education Institutions with the mission of fostering excellence in research and innovation by facilitating international cooperation. The ATHENA acronym stands for Advanced Technologies in Higher Education Alliance. The partner institutions are from France, Germany, Greece, Italy, Lithuania, Portugal, and Slovenia: the University of Orléans, the University of Siegen, the Hellenic Mediterranean University, the Niccolò Cusano University, the Vilnius Gediminas Technical University, the Polytechnic Institute of Porto, and the University of Maribor. In 2022 institutions from Poland and Spain joined the alliance: the Maria Curie-Skłodowska University and the University of Vigo. This research book presents a selection of the ATHENA university partners' research activities. It incorporates peer-reviewed original articles, reprints and student contributions. The ATHENA Research Book provides a platform that promotes joint and interdisciplinary research projects of both advanced and early-career researchers.*

**Keywords.** ATHENA European University, Erasmus+, research, interdisciplinarity, co-operation

Hellenic Mediterranean University  
Niccolò Cusano University  
Polytechnic Institute of Porto  
University of Maribor  
University of Orléans  
University of Siegen  
Vilnius Gediminas Technical University

---

<https://athenauni.eu>